

SHARP SERVICE MANUAL

No. 00ZFO5700USME



Illustration: FO-5700

FACSIMILE

MODEL FO-5700

In this Service Manual for FO-5700U which is provided with 2nd. cassette (FO-47UC) and memory PWB (FO-1MK), only the information which differs from that for FO-4700U/FO-47UC already issued is contained. For the information not contained, refer to the Service Manual for FO-4700U/FO-47UC (00ZFO4700USME) and FO-1MK (00ZFO1MKCUSME).

Difference between FO-4700U and FO-5700U

	FO-4700U	FO-5700U
2nd. cassette	OPTION (FO-47UC)	STANDARD EQUIPMENT
Memory PWB	OPTION (FO-1MK)	STANDARD EQUIPMENT
Control PWB unit	DCEKC082MXHZZ	DCEKC489MXHZZ

CAUTION

This laser facsimile is a class 1 laser product that complies with 21CFR 1040.10 and 1040.11 of the CDRH or IEC60825-1 standard. This means that this machine does not produce a hazardous laser radiation. The use of controls, adjustments or performance of procedures other than those specified herein may result in hazardous radiation exposure.

This laser radiation is not a danger to the skin, but when an exact focusing of the laser beam is achieved on the eyes retina, there is danger of spot damage to the retina.

The following cautions must be observed to avoid exposure of the laser beam to your eyes at the time of servicing.

- 1) When a problem in the laser optical unit has occurred, the whole optical unit must be exchanged as a unit, not an individual part.
- 2) Do not look into the machine with the main switch turned on after removing the toner/developer unit and drum cartridge.
- 3) Do not look into the laser beam exposure slit of the laser optical unit with the connector connected when removing and installing the optical system.
- 4) The cover of Laser Printer Unit contains the safety interlock switch.

Do not defeat the safety interlock by inserting wedges or other items into the switch slot.

Laser Wave Length : 770-810 nm
 Laser Pulse Times : 49.2 μ s
 Laser Output Power : 0.37 mW

Parts marked with "△" is important for maintaining the safety of the set. Be sure to replace these parts with specified ones for maintaining the safety and performance of the set.

CAUTION FOR BATTERY REPLACEMENT

- (Danish) ADVARSEL !
Lithiumbatteri-Eksplosionsfare ved fejlagtig håndtering.
Udskiftning må kun ske med batteri
af samme fabrikat og type.
Levér det brugte batteri tilbage til leverandoren.
- (English) Caution !
Danger of explosion if battery is incorrectly replaced.
Replace only with the same or equivalent type
recommended by the equipment manufacturer.
Discard used batteries according to manufacturer's instructions.
- (Finnish) VAROITUS
Paristo voi räjähtää, jos se on virheellisesti asennettu.
Vaihda paristo ainoastaan laitevalmistajan suosittelemaan
tyyppiin. Hävitä käytetty paristo valmistajan ohjeiden
mukaisesti.
- (French) ATTENTION
Il y a danger d'explosion s' il y a remplacement incorrect
de la batterie. Remplacer uniquement avec une batterie du
même type ou d'un type recommandé par le constructeur.
Mettre au rebut les batteries usagées conformément aux
instructions du fabricant.
- (Swedish) VARNING
Explosionsfare vid felaktigt batteribyte.
Använd samma batterityp eller en ekvivalent
typ som rekommenderas av apparatillverkaren.
Kassera använt batteri enligt fabrikantens
instruktion.
- (German) Achtung
Explosionsgefahr bei Verwendung inkorrektter Batterien.
Als Ersatzbatterien dürfen nur Batterien vom gleichen Typ oder
vom Hersteller empfohlene Batterien verwendet werden.
Entsorgung der gebrauchten Batterien nur nach den vom
Hersteller angegebenen Anweisungen.

CONTENTS

CHAPTER 1. GENERAL DESCRIPTION

[1] Specifications	1-1
[2] Refer to the service manual of FO-4700U/FO-47UC	
[3] Refer to the service manual of FO-4700U/FO-47UC	
[4] Refer to the service manual of FO-4700U/FO-47UC	
[5] Refer to the service manual of FO-4700U/FO-47UC	

CHAPTER 2. ADJUSTMENTS

[1] Adjustments	2-1
[2] Diagnostics and service soft switches	2-2
[3] Troubleshooting	2-35
[4] Error code table	2-36

CHAPTER 3. MECHANICAL DESCRIPTION

[1] Refer to the service manual of FO-4700U/FO-47UC	
[2] Refer to the service manual of FO-4700U/FO-47UC	
[3] Refer to the service manual of FO-4700U/FO-47UC	
[4] How to install the verification stamp (FO-45VS) refer to the service manual supplement of FO-4700U/FO-47UC	

CHAPTER 4. DIAGRAMS

[1] Block diagram	4-1
[2] Wiring diagram	4-2
[3] Point-to-point diagram and connector signal name	4-3

CHAPTER 5. CIRCUIT DESCRIPTION

[1] Circuit description	5-1
[2] Circuit description of control PWB	5-1
[2-1] Circuit description of memory PWB	5-19
[3] Refer to the service manual of FO-4700U/FO-47UC	
[4] Refer to the service manual of FO-4700U/FO-47UC	
[5] Refer to the service manual of FO-4700U/FO-47UC	
[6] Refer to the service manual of FO-4700U/FO-47UC	

CHAPTER 6. CIRCUIT SCHEMATICS AND PARTS LAYOUT

[1] Control PWB circuit	6-1
[2] LIU PWB circuit	6-19
[3] Printer PWB circuit	6-21
[4] Power supply PWB circuit	6-25
[5] Operation panel PWB circuit	6-27
[6] High voltage PWB circuit	6-29
[7] Toner empty PWB circuit	6-31
[8] 2nd. cassette PWB circuit	6-32
[9] Memory PWB circuit	6-34

CHAPTER 7. OPERATION FLOWCHART

[1] Refer to the service manual of FO-4700U/FO-47UC	
[2] Refer to the service manual of FO-4700U/FO-47UC	

CHAPTER 8. OTHERS

[1] Refer to the service manual of FO-4700U/FO-47UC	
[2] Refer to the service manual of FO-4700U/FO-47UC	

PARTS GUIDE

CHAPTER 1. GENERAL DESCRIPTION

[1] Specifications

• GENERAL

Automatic dialing	Rapid Key Dialing: 48 numbers Speed Dialing: 100 numbers	Effective Scanning width	8.3" (210 mm) max.
Memory size*	2 MB (approx. 116 pages with ECM off)	Effective Printing width	8.0" (203 mm) max.
Modem speed	33,600 bps (max.) Automatic fallback to lower speeds.	Reception modes	Auto/Manual
Transmission time*	Approx. 2 seconds	Instascan speed	30 ppm (letter paper)
Toner cartridge yield (4% page coverage)	Initial starter cartridge (included with fax machine): 3000 pages (avg.) (letter paper) Replacement cartridge (FO-47ND): 6000 pages (avg.) (letter paper)	Full Dual Access	Yes
Drum cartridge yield	Initial starter cartridge (included with fax machine): 20,000 pages (avg.) Replacement cartridge (FO-47DR): 20,000 pages (avg.)	Copy function	Single/Multi/Sort (99 copies/page)
Resolution	Horizontal: 203 pels/inch (8 pels/mm) Vertical: Standard: 98 lines/inch (3.85 lines/mm) Fine /Halftone: 196 lines/inch (7.7 lines/mm) Super fine: 391 lines/inch (15.4 lines mm)	Power requirements	120 V AC, 60 Hz
Automatic document feeder	50 pages max. (20 lb letter paper)	Operating temperature	50 - 86°F (10 - 30°C)
Paper capacity	750 sheets (tray and cassette)	Humidity	20 to 85% RH
Compression scheme	MMR, MR, MH, Sharp (H2) (Also supports JBIG)	Power consumption	Standby: 12 W Maximum: 580 W
Halftone (grayscale)	64 levels	Dimensions	Width: 18.1" (460 mm) Depth: 15.2" (385 mm) Height: 15.4" (390 mm)
Applicable telephone line	Public switched telephone network	Weight	Approx. 41.0 lbs.(18.6kg)
Compatibility	ITU-T (CCITT) G3 mode	* Based on ITU-T (CCITT) Test Chart #1 at standard resolution in Sharp special mode, excluding time for protocol signals (i.e., ITU-T phase C time only).	
Printing resolution	Horizontal: 406 lines/inch (16 lines/mm) Vertical: 391 lines/inch (15.4 lines/mm) PC Printing: 600 dpi	Option	
Input document size	Automatic feeding: Width: 5.8 to 10.1" (148 to 256 mm) Length: 5.0 to 14.3" (128 to 364 mm) Manual feeding: Width: 5.8 to 11.0" (148 to 279 mm) Length: 5.0 to 17.0" (128 to 432 mm)	Toner cartridge	: FO-47ND
		Drum cartridge	: FO-47DR
		PC interface	: FO-47IF
		Option memory	: FO-3MK
		Verification stamp	: FO-45VS

Note: This facsimile machine is Year 2000 compliant.

<IMPORTANT PLEASE READ FIRST>

To avoid problems with supplies, please don't use supplies from other units. Please use new supplies, when supply changes are required.

CHAPTER 2. ADJUSTMENTS

[1] Adjustments

General

Since the following adjustments and settings are provided for this model, make adjustments and/or setup as necessary.

1. Adjustments

Adjustments of output voltage (FACTORY ONLY)

1. Install the power supply unit in the machine.
2. Set the recording paper and document.
3. When the document is loaded, power is supplied to the output lines. Confirm that outputs are within the limits below.

Output voltage settings

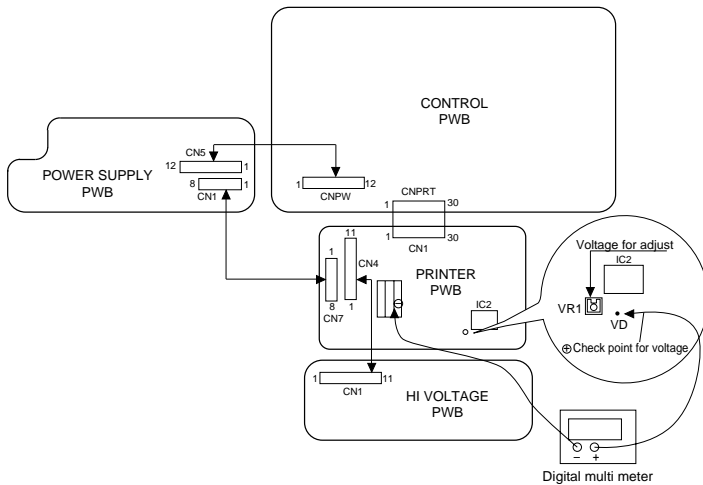

Fig. 1

Output	Voltage limits
+5V MAIN	4.845V~5.355V
+5V SUB	4.845V~5.355V
+24V MAIN	23.04V~24.96V
+24V SUB	23.04V~24.96V

Connector No. Pin No.	CN4	CN1
1	11	+5V
2	10	HV C HL
3	9	T VR
4	8	T REM
5	7	T MON
6	6	B MON
7	5	B VR
8	4	C REM
9	3	C MON
10	2	MG
11	1	+24

Connector No. Pin No.	CN5	CNPW
1	+24V SUB	
2	MG	
3	MG	
4	MG	
5	+24V MAIN	
6	+24V MAIN	
7	+5V SUB	
8	DG	
9	DG	
10	DG	
11	+5V MAIN	
12	+5V MAIN	

Connector No. Pin No.	CN1	CN7
1	24 MAIN	
2	MG	
3	DG	
4	5V MAIN	
5	HEATER ON	
6	FAN	
7	FAN LOCK	
8	H RELAY OFF	

ADJUST VOLTAGE LIST

Top Void Printer Label (mm.) Fig. 2	Adjust Voltage VR1 Fig. 1
5.5~6.9	4.42V
7.0~8.9	3.87V
9.0~10.9	3.14V
11.0~12.9	2.50V
13.0~14.9	1.86V
15.0~17.0	1.22V

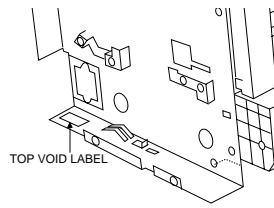

Fig. 2

2. IC protectors replacement

ICPs (IC Protectors) are installed to protect the TX motor drive circuit and verification stamp drive circuit. ICPs protect various ICs and electronic circuits from an overcurrent condition.

The location of ICPs are shown below:

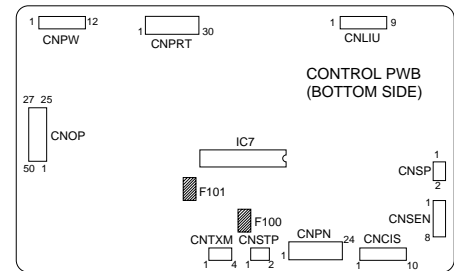

Fig. 3

- (1) F100 (ICPS10) is installed in order to protect IC's from an overcurrent generated in the verification stamp drive circuit. If F100 is open, replace it with a new one.
- (2) F101 (ICPS18) is installed in order to protect IC's from an overcurrent generated in the TX motor drive circuit. If F101 is open, replace it with a new one.

In addition to the replacement of F101 and F100, the factor causing F101 and F100 to open must also be repaired. If not, F101 and F100 will open again.

Replacement parts

ICPS10 (Sharp code: VHViCPS10// -1)

ICPS18 (Sharp code: VHViCPS18// -1)

3. Settings

(1) Dial mode selector

OPTION SETTING: DIAL MODE (Soft Switch No. SW2 DATA No. 1)
Use this to set the fax machine to the type of telephone line you are on.

- The factory setting is "TONE".

(step 1) Select "OPTION SETTING".

KEY: **FUNCTION** (4)

DISPLAY: 4:OPTIONAL SETTING
ENTER #(01-34,*,#,)

(step 2) Select "DIAL MODE".

KEY: (2)(2)

DISPLAY: DIAL MODE ↔ 1=TONE, 2=PULSE

Cursor
When initially registering, the mode shows 1=TONE. When registering again, the mode which was registered formerly is shown.

(step 3) Select, using "1" or "2".

KEY: (1)

DISPLAY: TONE SELECTED

KEY: (2)

DISPLAY: PULSE SELECTED

(step 4) End, using the "STOP" key.

KEY: STOP

[2] Diagnostics and service soft switches

1. Operating procedure

Two kinds of diagnoses are supported.

1-1. Fax diagnosis

This diagnosis is concerned with the main body of fax which is used for production and service support.

Entering the diagnostic mode

Press **FUNC** → **9** → ***** → **8** → **#** → **7**, and the following display will appear.

ROM: FAB0*

FAB0*

Then press the **START** key. Select the desired item with the ***** key and the **#** key or select with the rapid key.

Enter the mode with the **START** key.

(Diag •specifications)

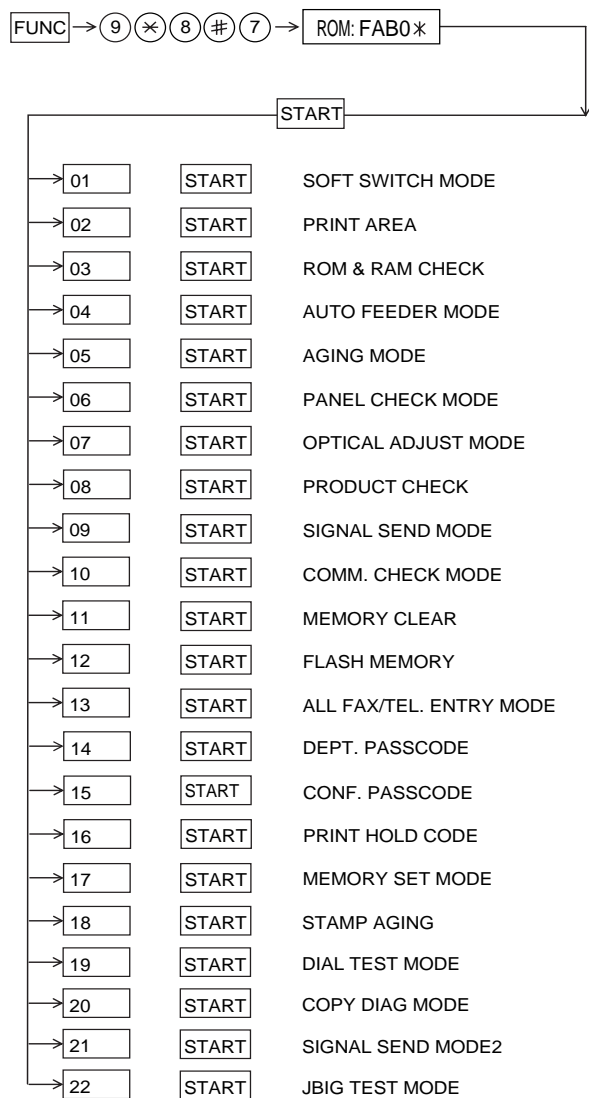

1-2. Print diagnosis

This diagnosis is concerned with the print which is used for production and service support.

Entering the diagnostic mode

Press **FUNC** → **9** → ***** → **8** → **#** → **6**, and the following display will appear.

PCU ROM Ver.: **

Then press the **START** key. Select the desired item with ***** the key and the **#** key or select with the rapid key.

Enter the mode with the **START** key.

(Diag •specifications)

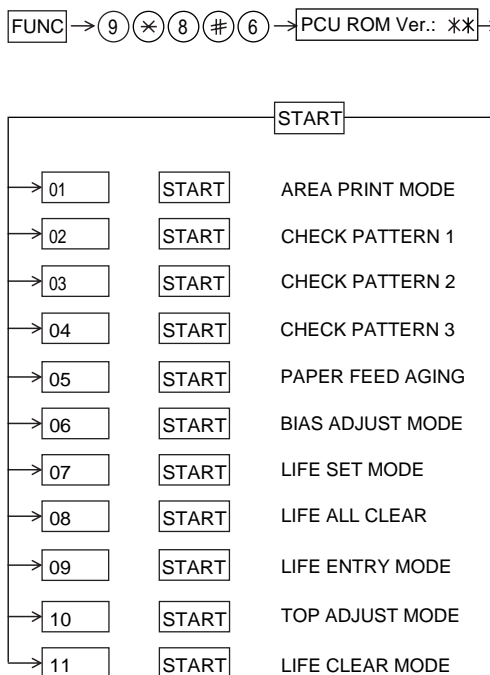

Memory clear when power is turned on

Pressing the **START** and **STOP** keys, turn on the main power, and the following message will be displayed.

MEMORY CLEAR
EXECUTE ? 1 = YES , 2 = NO

Here, when 1: YES is selected, the memory will be cleared to be ready for operation.

If 2: NO is selected, it will continue ready for operation as it is.

2. Diagnostic items description

2-1. Fax diagnosis

1) Soft switch mode

In this mode, the soft switch are set and the soft switch list is printed.

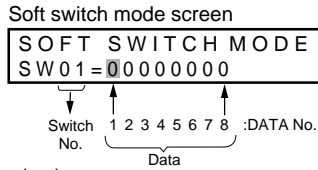

- ① Switch number selection
 - Press START key for setting of the next soft switch. If the soft switch number is the final, pressing START key will exit the soft switch mode.
 - Enter two digits of a soft switch number to set the switch number. If a switch number of unexisting soft switch is entered, key error buzzer sounds to reject the input.



- ② Data number selection

The cursor position shows the data to be set.
Pressing # key moves the cursor to the right. If, however, the cursor is on data number 8, pressing # key shifts the cursor to data number 1 of the next switch number. If the switch number is the final, pressing # key will exit the soft switch mode.
Pressing \times key moves the cursor to the left. If, however, the cursor is on data number 1, pressing \times key shifts the cursor to data number 1 of the former switch number. If the switch number is 1, pressing \times key will not move the cursor and the error buzzer will sound.
- ③ Data setting method

Press the FUNCTION key, and the data at the position of the cursor will be reversed to 0 when it is 1, or to 1 when it is 0. (If the soft switch can be changed at the bit (Refer to ⑥.), the error buzzer will sound with the process not received.)
- ④ Outputting method of soft switch list

In the soft switch mode, press the REPORT key, and the soft switch list will be output.
If the recording paper runs out or is clogged, the key error buzzer will sound with the process not received.
- ⑤ Storage of data

In the following case, the data of the soft switches set will be stored.

 - It is shifted to set the next soft switch by pressing the START switch.
 - It is shifted to set the next soft switch with the [#] key.
 - It is shifted to set the last soft switch with the [\times] key.
 - It is shifted to set another soft switch by inputting two digits as the switch number. (When 2 digits are completely input.)
 - Output of the soft switch list is started.
- ⑥ Inhibition of data change

(This is also applicable for the optional setting.)
In the following case, it is inhibited to change the data with the key error buzzer.

 - Switching ON/OFF of ECM during the use of image memory.
 - Switching OFF to ON of the print hold function when the print hold pass code has not yet been registered.
 - Clearing the print hold pass code when print hold function is ON.
 - Switching ON/OFF of the print hold function during the use of memory such as in the case of substitute receiving.

- OFF to ON of telephone billing function which is using the image memory is used (Note: In the existing set, the telephone billing code function is specified from OFF to ON when the timer system communication (including the batch communication) is set.) Here, the memory is usable when the telephone billing code function is on. It can be set from ON to OFF while the memory is used. However, if setting is practically changed even once, it can not be returned from OFF to ON.
 - Switching ON/OFF of PC interface function during the use of image memory.
 - OFF to ON of department control function during use of image memory. (Note: In the existing set, the department control function is set from OFF to ON when the timer communication (including the batch sending) or the memory hold is set.)
 - ON to OFF of continuous serial polling function when the continuous serial polling is started. (Note: In the existing set, "ON to OFF of the continuous serial polling function when the continuous serial polling is registered" has been applied, but the conditions are now moderated. However, registration is impossible to the program of the new continuous serial polling when the continuous serial polling function is OFF.)
 - In addition, change of all soft switches during communication
- ⑦ Linked change of data (This is the same even in the optional setting.)
 - When the department control function is off, the multi TTI function and telephone billing code function are turned off.

2) Print area

According to the size of the specified sheet, the effective printing area is printed.

3) ROM & RAM check

The sum value of ROM, the work and the back-up RAM are checked. The RS232C interface is also checked. If any error occurs, the buzzer will inform it. (Refer to the following table). Finally, the result will be printed. This diagnosis does not check the flash memory. The flash memory is checked with the flash memory test.

Number of buzzer sounds	Device checked	Remarks
1 time <Short sound>	ROM	Main
2 times <Short sounds>	Integrated ROM	Main
3 times <Short sounds>	SRAM	Main
4 times <Short sounds>	DRAM	Main

For the short and long sounds, one pattern is as follows.

Main system: 0.5 seconds ON/0.5 seconds OFF

Sub system: 1.00 second ON/0.5 seconds OFF

The execution state of checking is as follows. Moreover, the list of the check result is output after checking is ended.

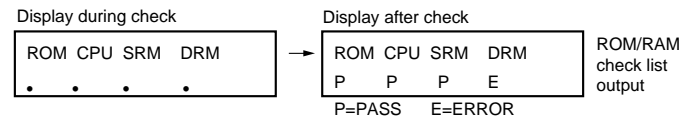

4) Auto feeder mode

The auto feed function can be checked by inserting and discharging the document. (The distance between pages can be displayed during operation of the scanner.)

① Check of auto feed function

After this mode is activated, set up the document, and press the START key, and it will be automatically fed. (Before the START key is pressed, the document sensor alone is activated.) Moreover, the document size (A4/B4) and sensor information (A4/B4/ORG) are displayed when the document sensor is turned.

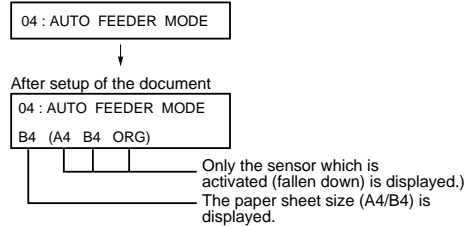

② Display of distance between pages during operation of the scanner

- Soon after this mode is activated, press the FUNCTION key for 5 seconds or more, and the display mode of the distance between pages will be activated. Then, set up the sending paper and select the image quality, and then press the START key, and operation will be started.

Be sure to press the FUNCTION key prior to the START key. If the FUNCTION key is not pressed but the START key is pressed, it will operate in the same matter as in the existing auto feeder mode.

If the START key is pressed, the FUNCTION key will be invalid hereafter. Therefore, the display mode of the distance between pages and the existing mode can not be changed.

- While the sending paper is read, the image quality key can be input. STD/FINE/S-FINE modes are usable. However, the same operation of FINE will be selected if the intermediate tone is set.
- The image quality, the length of the sending page read, the page distance to the next sending paper and the total of the sending papers read are shown on the display.
- When the stop key is pressed or 100 sending papers are read, the content shown on the display will be totally output as the list after the remaining sending papers are discharged.

5) Aging mode

If any document is set up in the first state (when started), copying will be executed. If it is not set up, "check pattern 1" of the print diagnosis is output at the intervals of 1 time/60 minutes. (A total of 10 sheets are output.)

6) Panel check mode

This is used to check whether each key is normally operated or not. According to the key input, LCD is displayed. Moreover, during execution, the document reading lamp is turned on.

Test results are printed. (The maximum 100 input keys can be printed.) LED repeats lighting at regular intervals in sequence. (Lighting speed is specified separately.)

In case of inputting all keys, key input OK is displayed when finishing the STOP key.

When pressing the NUMERIC key during panel check, output of DTMF corresponding with the key is started.

When pressing other keys, output is stopped.

7) Optical adjust mode

Set documents and press the START key for ordinary copying. According to key operation, copying can be temporarily stopped.

STOP key: To temporarily stop reading documents.

START key: To start reading documents again.

When any document is not set, print area printing is performed.

8) Product check

The diagnosis is used in the production process.

After shift to the mode, the following operations are sequentially executed. At this time, the sensor of read-error can be checked by feeding the B4 document. Set up one short document of B4 size.

① Memory clear (Same as Diagnosis 11)

② Panel test (Same as Diagnosis 06)

③ Dial test (Same as Diagnosis 24)

④ Document auto feed

⑤ ROM & RAM test check (Same as the Diagnosis 03)

⑥ Flash memory test mode (Same as Diagnosis 12)

⑦ Registration of fixed data

Registration of rapid key No. and other data necessary for production.

The registered data are shown in the following table. The chain dial is not set for any destination.

Rapid No.	FAX No.	Rapid No.	FAX No.	Rapid No.	FAX No.	Rapid No.	FAX No.
01	20	06	25	11	1	21	01
02	21	07	26	12	2	22	02
03	22	08	27	13	3	23	03
04	23	09	28	14	4	24	04
05	24	10	29	15	5	25	05

⑧ Transmission check (Same as Diagnosis 10)

The soft switches necessary for production are set.

⑨ Test result print (one sheet)

Memory clear printing
Panel test result printing
ROM & RAM test result printing

⑩ Print area printing (one sheet)

9) Signal send mode

After shift to the mode, press the START key, and the signals will be transmitted in the following sequence.

It can be used to check the modem and so on.

- [1] No signals
- [2] 4800BPS (V27ter)
- [3] 14400BPS (V. 33)
- [4] 12000BPS (V. 33)
- [5] 14400BPS (V. 17)
- [6] 12000BPS (V. 17)
- [7] 9600BPS (V. 17)
- [8] 7200BPS (V. 17)
- [9] 9600BPS (V. 29)
- [10] 7200BPS (V. 29)
- [11] 4800BPS (V27ter)
- [12] 2400BPS (V27ter)
- [13] 300BPS (FLAG)
- [14] 2100Hz (CED)
- [15] 1100Hz (CNG)

10) Comm. check mode

- ① Turn on the line monitor.
- ② Turn off the COVER SHEET FUNCTION.
- ③ Set line equivalence at 0 km.

After the check, it is necessary to be sure to return the aforementioned soft switches into the initial state.
(Clear the memory with the diagnosis.)

11) Memory clear

Clear the back-up memory to initialize the soft switches.
The flash memory will be initialized. Then, the initialized list be output.

12) Flash memory

The flash memory is checked.
The ordinary memories (ROM, SRAM, DRAM) are checked in the ROM & RAM check process. The write/read test is taken every block to print the result.

When an error occurs, the following error buzzer will sound.

Number of buzzer sounds	Check device
9 times <Short sounds>	Flash memory (Option)

During operation of this diagnosis, dual operation is not possible at all.
If this is excessively repeated, it will shorten the life of the flash memory.

13) All FAX/TEL. entry mode

The function is used to simplify the registration of FAX/TEL No. during aging.

- ① The diagnosis mode is activated. If anything is not registered in the Rapid number 01 or any program or group is not registered, it will pass the diagnosis without doing anything.
- ② The FAX/TEL number (including the substitutive destination) of the Rapid number 01 is copied to the Rapid numbers 02 thru 48.
- ③ FAX number of the Rapid number 01 is copied to SPEED key numbers 001 thru 200.

- ④ If any chain dial is not in the Rapid number, the Rapid numbers 02 thru 48 and SPEED key numbers 001 thru 200 are registered in the group number 01.
If any chain dial is set, the group will be not produced but the chain dial setting alone of the Rapid number 01 will be reset.
(In all others except the Rapid number 01, the chain dials will be continuously set as they are.)

Rapid key	RXX	XX	:	Rapid number
SPEED key	SXXX	XXX	:	Speed key number

(16th and subsequential letters of the destination name registered in the Rapid number 01 will be discarded.)

14) Dept. passcode

The department passcode list is printed.

15) Conf. passcode

The confidential passcode list is printed.
Differing from printing of one box alone soon after registration, the confidential passcodes of all boxes are printed.

16) Print hold code

The print lockout passcode No. is printed.

17) Memory set mode

The set and dump list of the memory content is output.

- The address (8 digits (P) generally including the bank information is input, and the data of 2 digits is continuously input.
Inputting is done in the hexadecimal mode. The ten-key is used for 0 thru 9, and the alphabetic keys A (RAPID 01 thru 06) are used for A thru F.
- During data inputting, the address can be moved forward and backward one byte by one byte with "×" and "#". (The address prior to the address 0 is looped as the maximum address.)
- The Validity of the address is not checked. Accordingly, writing/ reading operations are possible in the address of the memory not assigned, the address of ROM and so on.
(However, as practical, writing is not done, and the data content runs short each reading.)
Though writing is possible in the flash memory, a little time is required.
It is also necessary to take care that the life of the flash memory is excessively shortened if much data is written in the flash memory. Since it may run away depending the written content, take minute care for the writing address.
- When the REPORT key is input, the memory dump list is produced from the displayed address (here, it is limited at the 16-byte boundary address (address with end 0) which does not exceed the specified address and is just in front.). The dump list is output to a maximum of 99 pages. If any data of one page can be repeatedly developed and printed, the list is sufficient. But it is not desired that the content of plural pages are developed in the memory once and are then printed. If the STOP key is pressed, it will pass to the diagnosis after the page which is now being printed is completed printed.
If the address exceeds the maximum address, it will return to the address 0 and printing will be continued.

18) Stamp aging

Diag mode is left though it doesn't have this function.

19) Dial test mode

The mode is used to inspect whether dialing is accurate in two kinds of dial modes. All data which can be dialed in this mode are automatically called up in both PB mode and DP mode.

When this mode is activated, the following operations will be automatically executed. Whether the dialed content is right or not is judged with the external instrument which is connected to the line cable.

- ① After shift to the FAX diagnosis mode, press RAPID 24.
(Also switch the display with the [×] and [#] keys.)
- ② Press the START key.
- ③ Turn on CML, and dial the following in the PB mode.
1, 2, 3, 4, 5, 6, 7, 8, 9, ×, 0, #
- ④ Turn off CML 500 mS alone.
- ⑤ Dial the following in the DP mode.
1, 5, 9, 0
- ⑥ After dialing, turn off CML.

This mode uses the ordinary auto dial. (Accordingly, the signal sending time and minimum pause are all the same as ordinary.)

The measurement result in this mode is completely all the same as in the ordinary dial mode.

Moreover, the same process as above is also done in the dial test mode which is executed in the product check mode.

20) Copy diag mode

In order to shorten the process time during production, this mode is used to automatically switch the copy mode. Three menus are provided.

1. ① Set up two documents. (In case of two documents or more, there is no problem.)
- ② Press the START key.
- ③ Copy 1st document in the fine mode/density AUTO. (One sheet is printed in the ordinary copy mode.)
- ④ Copy 2nd (subsequential) document in the intermediate tone mode/density DARK. (In the ordinary copying mode, one sheet is printed when the RESOLUTION key is pressed three times.)

When copy test is tried during production or is checked in two modes (fine and intermediate tones), this mode is provided to reduce the troublesome work which makes the operator stand aside to change the mode. Accordingly, the fine and intermediate tones are merely switched, and the mode is not switched to another mode. (Input of the image quality/density key is invalid.)

2. Try the copy in the mode fixed at COPY REDUCE 95% and fine mode/density AUTO. At this time, don't change the soft key of COPY REDUCE. (Input of the image quality/density key is invalid.)
3. Continuously try the above items 1 and 2.

21) Signal Send Mode2

The signals concerned with V.34 & V.8 are checked.

After this mode is activated, press the START key, and the signals will be sent in the following sequence.

It can be used to check the modem.

- [1] No signal
- [2] 33600BPS
- [3] 31200BPS
- [4] 28800BPS
- [5] 26400BPS
- [6] 24000BPS
- [7] 21600BPS
- [8] 19200BPS
- [9] 16800BPS
- [10] 14400BPS
- [11] 12000BPS
- [12] 9600BPS
- [13] 7200BPS
- [14] 4800BPS
- [15] 2400BPS

22) JBIG Test Mode

- ① Enter the diagnostic mode.
- ② Press the RAPID22 button. ("22: JBIG TEST MODE" appears.)
- ③ Press the START key to begin the JBIG test operation.

When both tests are completed normally, the buzzer sounds and "JBIG TEST NORMAL END" appears at the same time.

If the decoding test terminates abnormally, the buzzer sounds and "ERROR: JBIG DECODE" appears at the same time.

If the encoding test terminates abnormally, the buzzer sounds and "ERROR: JBIG ENCODE" appears at the same time.

2-2. Print diagnosis

Rapid key 01: Area print mode

The effective printing area frame is printed in the specified sheet size.

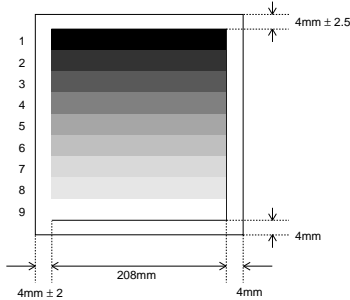

- 1. [Full black pattern]
- 2. [Intermediate tone 2 pattern]

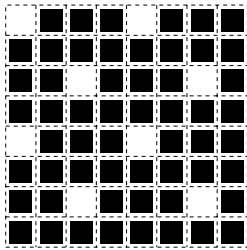

The left pattern is repeated.

- 3. [Intermediate tone 1 pattern]

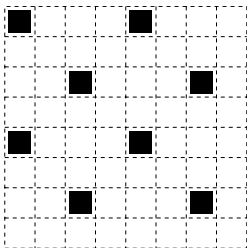

The left pattern is repeated.

- 4. [Mesh point pattern]

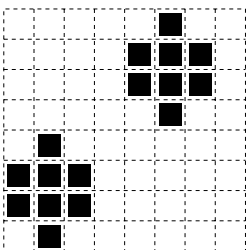

The left pattern is repeated.

- 5. [Longitudinal strip 2 pattern]
Black 2 dot and white 2 dot are repeated in line.
- 6. [Lateral strip 2 pattern]
Black 2 line and white 2 line are repeated.
- 7. [Longitudinal strip 1 pattern]
Black 1 dot and white 1 dot are repeated in line.
- 8. [Lateral strip 1 pattern]
Black 1 line and white 1 line are repeated.
- 9. [Full White pattern]

Rapid key 02: Check pattern 1

The lateral stripe 2 pattern is printed on one sheet. (Black 2 line and white 2 line are repeated.)

Rapid key 03: Check pattern 2

The lateral stripe 2 pattern is printed on multiple pages. Press the STOP key to end the printing.

Rapid key 04: Check pattern 3

The intermediate tone 1 is printed on one sheet.

Rapid key 05: Paper feed aging

The mode is used for aging related to the printing. In this mode, the following modes are provided.

- ① Blank paper aging mode (ALL WHITE AGING)
- ② Whole black print aging mode (ALL BLACK AGING)
- ③ 4% printing aging mode (4% AGING)

After selecting the paper-pass aging mode in the print diagnosis mode, input the number of each mode above with the ten-key, and the mode will be executed. The detailed specifications of each mode are described as follows. Here, the operation in each mode is stopped only when the STOP key is pressed by the operator or a printing-impossible error occurs.

- Blank paper aging mode
In the mode, printing is continued in the whole white (white paper) printing pattern until the STOP key is pressed by the operator. (In the printing area)
- Whole black printing aging mode
In the mode, printing is continued in the whole black (whole black) printing pattern until the STOP key is pressed by the operator. (In the printing area)

Rapid key 06: Bias adjust mode

The mode is used to adjust the printing density of the printed image. The image printing density is adjustable in seven steps of 1 to 7.

For details, refer to the following table. (For selection, use the keys 1 thru 7.)

Image printing density	Thin	←	→	Thick			
	1	2	3	4	5	6	7
Default value				⊙			

Rapid key 07: Life set mode

The mode is used to set the life counter of the printer and the counter of the auto feeder at desired values. For setting, proceed with the following procedure.

- ① When the life counter setting mode is selected, the following will be displayed.

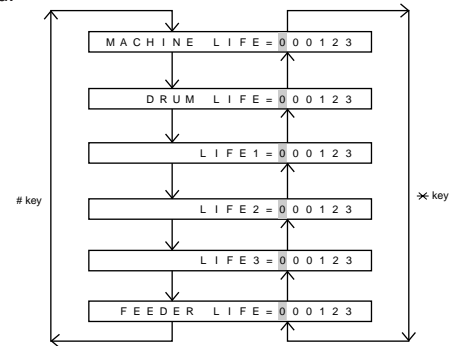

The cursor blinks at the top data. Five counters can be selected with the "#" and "*" keys.

- ② In the state ①, input a desired setting number of 6 digits with the ten-key.
- ③ After input of 6 digits, shift to another counter with the "#" and "*" keys as necessary. When all necessary counters are completely input, press the START key.
- ④ "STORED" will be displayed with the set values stored into the memory. For checking, retry this mode.

Note:

This counter indicates the printer use conditions such as numbers of printed pages from the beginning of use. In the normal memory clear condition, the counter will not be reset.

In conditions including damaged memory contents caused by repairing the panel, this counter should be reset or cleared in addition to the ordinary memory clear.

Rapid key 08: Life all clear

The mode is used to clear the life counter of the printer of the counter of the auto feeder.

Note: The counter shows the operational state of the printer (e.g. how many sheets have been printed since start of use?). The ordinary memory does not reset the counter. Accordingly, it is necessary to reset this counter in addition to the ordinary memory clear if the content in the memory on the control PWB is broken because of PWB repair, etc. (In the production stage, it is necessary to execute this in the last process.)

**Rapid key 09: Life entry mode
(For Serviceman temporary counter)**

The mode is used to set a desired value for the judgment value (alarm judgment counter value) of the general purpose life counters 1 thru 3 of the printer. If the life of a consumable part (developer, imprinter, etc) is set, the model which has the error display and RMS function will inform RMS when the counter reaches the set value. For setting, proceed with the following procedure.

- ① When the life counter setting mode is selected, the following will be displayed.

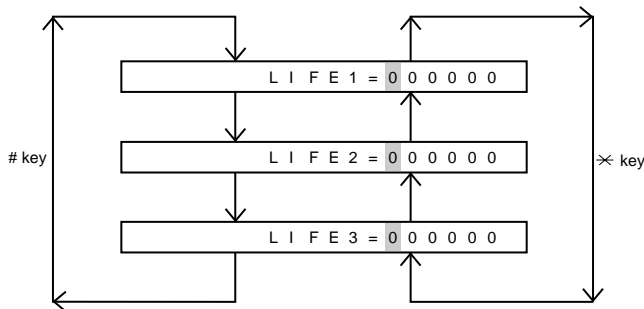

The cursor blinks at the top data.
Three counters can be selected with the "#" and "x" keys.

- ② In the state ①, input a desired setting number of 6 digits with the ten-key.
- ③ After input of 6 digits, shift to another counter with the "#" and "x" keys as necessary. When all necessary counters are completely input, press the START key.
- ④ "STORED" will be displayed with the set values stored into the memory. For checking, retry this mode.

Note: The counter shows the operational state of the printer (how many sheets have been printed since start of use? and others). The ordinary memory does not reset the counter. Accordingly, it is necessary to reset the counter or do the clear process in addition to the ordinary memory clear if the content in the memory on the control PWB is broken because of PWB repair, etc. (In the production stage, it is necessary to execute this in the last process.)

Rapid key 10: Top adjust mode

As the method to adjust the top margin for printing, adjust top margin adjusting VR on the PWB. If this mode is used at this time, adjustment is possible without the printing test every time when VR is turned. For the practical use, determine the adjusting value on the basis of the old data, and adjust to the determined value in this mode. Then, check it with the printing test.

Rapid key 11: Life clear mode

The mode is used to respectively clear the life counter of the printer and the counter of the auto feeder. For setting, proceed with the following procedure.

- ① When the life counter clearing mode is selected, the following will be displayed.
Seven counters can be selected with the "#" and "x" keys.

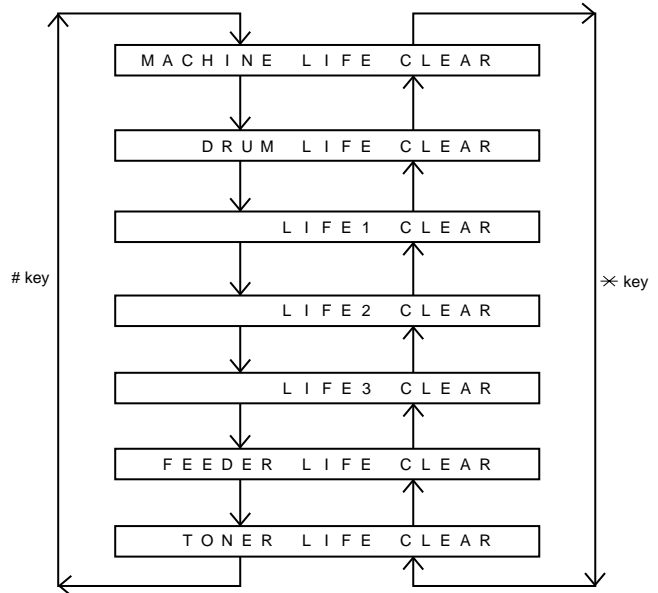

- ② In the state ①, input the CLEAR key, and the counter will be respectively cleared.
- ③ After one clear, move the cursor to another counter with the "#" and "x" keys as necessary, and then press the CLEAR key. When the necessary counters are completely cleared, press the STOP key.

3. How to make soft switch setting

To enter the soft switch mode, make the following key entries in sequence.

Press **FUNCTION** **9** ***** **8** **#** **7** **START** **0 1** **START**

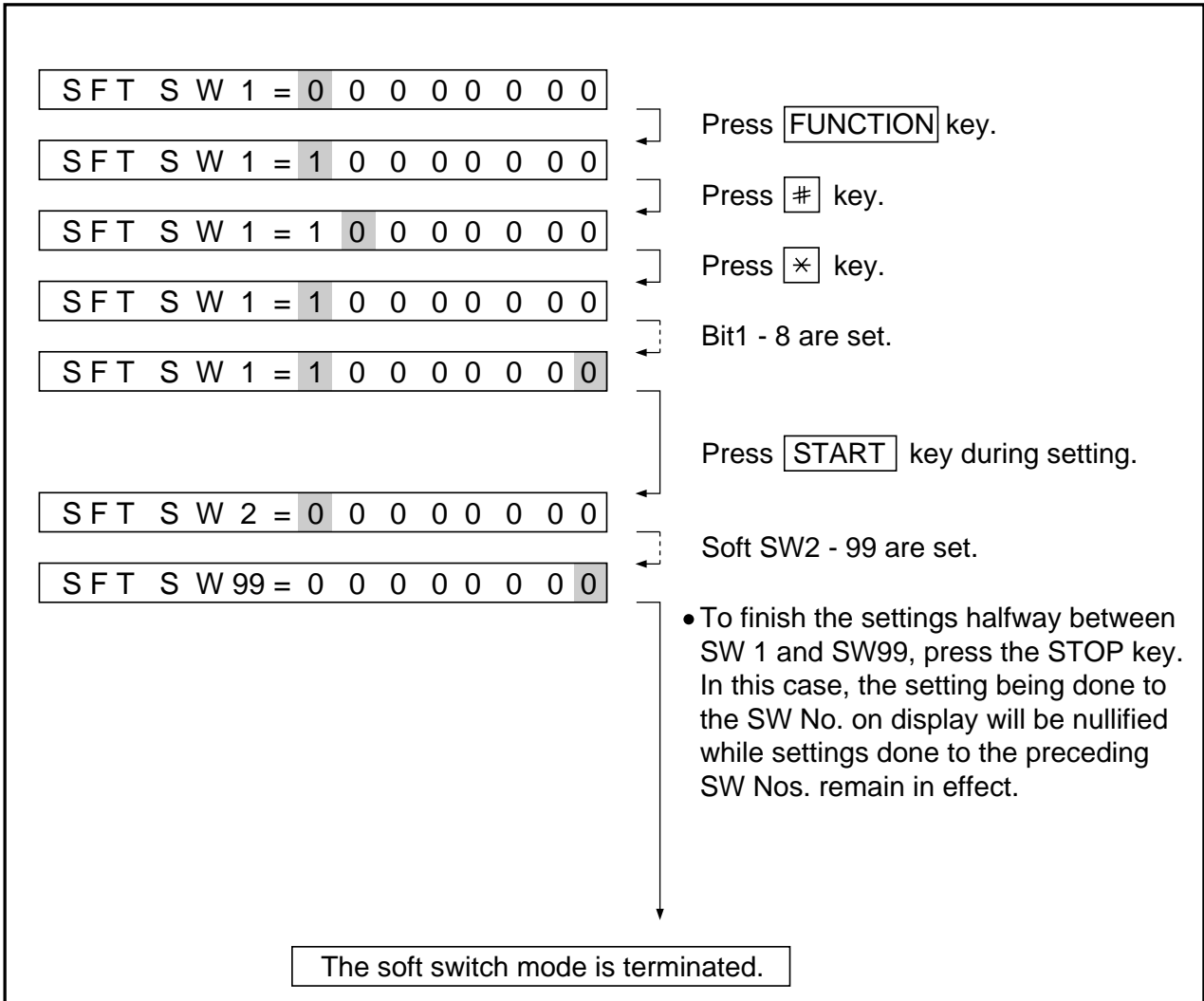

4. Soft switch description

• Soft switch

SW NO.	DATA NO.	ITEM	Switch setting and function					Initial setting	Remarks	
			1			0				
SW1	1	Recall interval	Binary input 8 4 2 1					0	OPTION Set to 1~15	
	2		No. = 1 2 3 4 (Data No.)					1		
	3		EX 0 1 0 1					0		
	4		eg. Recall interval is set to 5 min.					1		
	5	Recall times	Binary input 8 4 2 1					0	OPTION Set to 0~14	
	6		No. = 5 6 7 8 (Data No.)					0		
	7		EX 0 0 1 0					1		
	8		eg. Recall times is set to 2 times.					0		
SW2	1	Dial mode	PULSE			TONE		0		
	2	Receive mode	AUTO			MANUAL		1		
	3	ECM mode	Off			On		0	OPTION	
	4	Reserved						0		
	5	Polling security	On			Off		1	OPTION	
	6	Auto cover sheet	No			Yes		1	OPTION	
	7	JUNK-FAX function in manual reception	Yes			No		0		
	8	JUNK-FAX function	Yes			No		0	OPTION	
SW3	1	Number of rings for auto-receive (0: No ring receive)	Binary input 8 4 2 1					0	OPTION Set to 0~9	
	2		No. = 1 2 3 4 (Data No.)					0		
	3		EX 0 0 0 1					0		
	4		eg. Number of rings for auto receive is set to 1 time.					1		
	5	Switch to auto-receive from manual receive (0: No switch)	Binary input 8 4 2 1					0	OPTION Set to 0~9	
	6		No. = 5 6 7 8 (Data No.)					0		
	7		EX 0 0 0 0					0		
	8		eg. Switch to auto receive is set to disable.					0		
SW4		Communication results printout		Printed at error only	Printed at error/timer/memory only	Printed at transmission mode only	Not printed	Printed every time	OPTION	
	1		No. 1	0	0	0	1	1		0
	2		No. 2	0	0	1	0	1		0
	3		No. 3	1	0	0	0	0		1
	4	Image addition function to the communication result table (for memory transmission only)	On			Off		1	OPTION	
	5	Reserved						0		
	6	TEL billing code function	On			Off		0	OPTION	
	7	Billing code position	Before			After		1	OPTION	
	8	Multi-TTI feature	On			Off		0	OPTION	
	SW5	1	Time display format	24 hours			12 hours-AM/PM		0	
2		Date display format	Month-Day-Year			Day-Month-Year		1		
3		Header print	Off			On		0		
4		Footer print	On			Off		0		
5		Relay data output	No			Yes		0		
6		Substitute reception	Off			On		0		
7		Substitute reception conditions	Reception disable without TSI			Reception enable without TSI		0		
8		CSI transmission	Off			On		0		

SW NO.	DATA NO.	ITEM	Switch setting and function						Initial setting	Remarks				
			1			0								
SW6	1	JBIG (Joint Bi-level Image Group)	On			Off			1					
	2	JBIG option	On			Off			0					
	3	MMR	On			Off			1					
	4	MR	On			Off			1					
		Modem speed		V.33		V.17		V. 29	V. 27ter					
	5		No. 5	0	0	1	1	1	1	0	0	0	1	
	6		No. 6	1	1	0	0	0	0	0	0	0	0	
	7		No. 7	0	1	0	1	0	1	0	1	1	0	0
8		No. 8	0	0	0	0	1	1	1	1	0	0	0	
SW7	1	Reception speed fixed				NO	V. 17- 14400BPS	V. 29- 9600BPS	V. 27ter- 4800BPS		0	When 14400BPS MODEM used, setting to 14400BPS is ignored.		
	2		No. 1	0	1	0	1	0						
			No. 2	0	1	1	0	0						
	3	DIS receive acknowledge during G3 transmission	Twice			Once in NSF reception, twice in DIS reception				0	Effective to international comm.			
	4	Non-modulated carrier in V.29 transmission mode	On			Off				0				
	5	CNG send in manual transmission	On			Off				1				
	6	Protocol monitor	On			Off				0				
	7	Line monitor	On			Off				0				
8	Max. length for TX/RX/Copy	TX: unlimited, RX: unlimited			TX/Copy: 1.0m, RX: 1.5m				0					
SW8	1	Compromised equalizer				0Km	1.8Km	3.6Km	7.2Km		0	Valid when transmitting		
	2		No. 1	0	0	1	1							
			No. 2	0	1	0	1							
	3	H2 mode	No			Yes				0				
	4	Signal transmission level	Binary input 16 8 4 2 1									0		
	5		No. = 4 5 6 7 8 (Data No.)									1		
	6		EX 0 1 1 0 1									1		
	7		eg. Signal transmission level is set to -10dBm									0		
8											1			

SW NO.	DATA NO.	ITEM	Switch setting and function					Initial setting	Remarks	
			1		0					
SW9	1	CED tone signal interval		75ms	500ms	750ms	1000ms	0		
	2		No. 1	0	0	1	1			
	3		No. 2	0	1	0	1			
	4	Equalization freeze	On			Off			0	
	5	Equalization freeze conditions	All			7200bps			0	
	6	CED detection time	500ms			1000ms			0	
	7	Alarm buzzer		3sec	1sec	No BEEP	No BEEP	0		
	8		No. 5	0	0	1	1			
9	No. 6	0	1	0	1	0	0			
10	Action when RTN received	Not Error			Error			0		
SW10	1	Memory retransmission times	Binary input 8 4 2 1				1	OPTION		
	2		No. = 1 2 3 4 (Data No.)							
	3		EX 1 0 1 0							
	4		eg. Retransmission time set to 10 times.							
	5	Memory retransmission interval	Binary input 8 4 2 1				0	OPTION		
	6		No. = 5 6 7 8 (Data No.)							
	7		EX 0 0 1 0							
	8									
SW11	1	Reserved					1			
	2	Reserved					1			
	3	Reserved					1			
	4	Reserved					0			
	5	Reserved					1			
	6	Reserved					1			
	7	Reserved					1			
	8	Reserved					0			
SW12	1	Reserved					1			
	2	Reserved					1			
	3	Reserved					0			
	4	EOL detection timer		13sec	25sec	5sec	5sec	0		
	5		No. 4	0	0	1	1			
	6	Processing of DIS reception after DIS transmission		Retransmitting command	Breaking circuit	Apply to T.30	T.30+α	0		
	7		No. 6	0	0	1	1			
	8	No. 7	0	1	0	1	0			
9	The change to DB from DP by ∞	Yes			No			0		
SW13	1	DTMF output level (High)	Binary input 16 8 4 2 1				0			
	2		No. = 4 5 6 7 8 (Data No.) n = 0.5dBm							
	3		EX 0 1 1 0 0							
	4		eg. Signal transmission level is set to -10dBm							
	5									
	6	Reserved					0			
	7	Reserved					0			
	8	Reserved					0			
SW14	1	DTMF output level (Low)	Binary input 16 8 4 2 1				1			
	2		No. = 4 5 6 7 8 (Data No.) n = 0.5dBm							
	3		EX 1 0 0 0 0							
	4		eg. Signal transmission level is set to -10dBm							
	5									
	6	Reserved					0			
	7	Reserved					0			
	8	Reserved					0			

SW NO.	DATA NO.	ITEM	Switch setting and function								Initial setting	Remarks
			1				0					
SW15	1	Reserved									0	
	2	Reserved									0	
	3	Reserved									0	
	4	Reserved									0	
	5	Reserved									0	
	6	Reserved									0	
	7	Reserved									0	
	8	Reserved									0	
SW16	1	Reserved									0	
	2	Reserved									0	
	3	Reserved									0	
	4	Reserved									0	
	5	CI Signal OFF detect enable time	(ms)	200	300	350	400	500	700	1200		
	6		No. 5	0	0	0	0	0	0	0	0	
	7		No. 6	0	0	0	0	1	1	1	1	1
	8		No. 7	0	0	1	1	0	0	1	1	0
	No. 8		0	1	0	1	0	1	0	0	1	
SW17	1	Reserved									0	
	2	Reserved									0	
	3	Reserved									0	
	4	Reserved									0	
	5	Distinctive ringing		OFF	STD	RING1	RING2	RING3	RING4	RING5		
	6		No. 5	0	0	1	0	1	0	1	0	
	7		No. 6	0	0	0	1	1	0	0	0	0
	8		No. 7	0	0	0	0	0	1	1	0	0
	No. 8		0	1	0	0	0	0	0	0	0	
SW18	1	Reserved									0	
	2	Reserved									0	
	3	Reserved									0	
	4	Reserved									0	
	5	Reserved									0	
	6	Reserved									0	
	7	Reserved									0	
	8	Reserved									0	
SW19	1	Reserved									0	
	2	Reserved									0	
	3	Reserved									0	
	4	Reserved									1	
	5	Reserved									1	
	6	Reserved									0	
	7	Reserved									0	
	8	Reserved									0	
SW20	1	Reserved									0	
	2	Reserved									0	
	3	Reserved									1	
	4	Reserved									1	
	5	Reserved									0	
	6	Reserved									0	
	7	Reserved									0	
	8	Reserved									0	

SW NO.	DATA NO.	ITEM	Switch setting and function					Initial setting	Remarks	
			1		0					
SW21	1	Reserved						1		
	2	Reserved						0		
	3	Reserved						0		
	4	Reserved						0		
	5	Reserved						1		
	6	Reserved						0		
	7	Reserved						0		
	8	Reserved						0		
SW22	1	Reserved						0		
	2	Reserved						0		
	3	Reserved						0		
	4	Reserved						0		
	5	Reserved						0		
	6	Reserved						0		
	7	Reserved						0		
	8	Reserved						0		
SW23	1	Reserved						0		
	2	Reserved						0		
	3	Reserved						0		
	4	Busy tone detection frequency		520-640Hz	300-600Hz	380-500Hz	reserve	reserve		
			No. 4	0	0	0	0	1	0	
			No. 5	0	0	1	1	0	0	
		No. 6	0	1	0	1	0	0	0	
7	Reserved							0		
8	Reserved							0		
SW24	1	Reserved						0		
	2	Reserved						0		
	3	Reserved						0		
	4	Reserved						0		
	5	Reserved						0		
	6	Reserved						0		
	7	Reserved						0		
	8	Reserved						0		
SW25	1	Reserved						0		
	2	Reserved						0		
	3	Reserved						0		
	4	Reserved						0		
	5	Reserved						0		
	6	Reserved						0		
	7	Reserved						0		
	8	Reserved						0		
SW26	1	Reserved						0		
	2	Reserved						0		
	3	Reserved						0		
	4	Reserved						0		
	5	Reserved						0		
	6	Reserved						0		
	7	Reserved						0		
	8	Reserved						0		

SW NO.	DATA NO.	ITEM	Switch setting and function					Initial setting	Remarks	
			1		0					
SW27	1	F.A.S.T (RMS) mode	On		Off			0		
	2	Reserved						0		
	3	Verification STAMP	Yes		No			0		
	4	Summer time (Day light saving)	No		Yes			1		
	5	Key buzzer volume		Off	HIGH	MIDDLE	LOW	1		
			No. 5	0	0	1	1			
			No. 6	0	1	0	1			
	6							0		
7	Reserved						0			
8	Reserved						0			
SW28	1	Speaker volume		HIGH	HIGH	MIDDLE	LOW	1		
			No. 1	0	0	1	1			
			No. 2	0	1	0	1			
	2							1		
	3	Reserved						1		
	4	Reserved						0		
	5	Ringer volume		Off	HIGH	MIDDLE	LOW	1		
			No. 5	0	0	1	1			
No. 6			0	1	0	1				
6							1			
7	Reserved						0			
8	Reserved						0			
SW29	1	Reserved						0		
	2	PC I/F mode	On		Off			1	OPTION	
	3	Reserved						0		
	4	Reserved						0		
	5	Reserved						0		
	6	Reserved						0		
	7	Reserved						0		
	8	Reserved						0		
SW30	1	Header registration	On		Off			0		
	2	Reserved						0		
	3	Reserved						0		
	4	Reserved						0		
	5	Reserved						0		
	6	Reserved						0		
	7	Reserved						0		
	8	Quick on-line function	Yes		No			1		
SW31	1	Cassette selection		Manual	Auto-1	Auto-2	Auto-1	0	OPTION	
			No. 1	0	0	1	1			
			No. 2	0	1	0	1			
	2				None	Tray	1st. Cass.	2nd. Cass.	1	OPTION It is effective only when No.31-1/2 are set up of manual
				No. 3	0	0	0	0		
				No. 4	0	0	1	1		
	3	The first priority cassette			None	Tray	1st. Cass.	2nd. Cass.	0	OPTION It is effective only when No.31-1/2 are set up of manual
				No. 3	0	0	0	0		
				No. 4	0	0	1	1		
	4				None	Tray	1st. Cass.	2nd. Cass.	1	OPTION It is effective only when No.31-1/2 are set up of manual
				No. 5	0	1	0	1		
				No. 6	0	0	0	0		
5	The second priority cassette			None	Tray	1st. Cass.	2nd. Cass.	0	OPTION It is effective only when No.31-1/2 are set up of manual	
			No. 6	0	0	0	0			
			No. 7	0	0	1	1			
6				None	Tray	1st. Cass.	2nd. Cass.	1	OPTION It is effective only when No.31-1/2 are set up of manual	
			No. 7	0	0	1	1			
			No. 8	0	1	0	1			
7				None	Tray	1st. Cass.	2nd. Cass.	1	OPTION It is effective only when No.31-1/2 are set up of manual	
			No. 7	0	0	1	1			
			No. 8	0	1	0	1			
8				None	Tray	1st. Cass.	2nd. Cass.	1	OPTION It is effective only when No.31-1/2 are set up of manual	
			No. 8	0	1	0	1			
			No. 8	0	1	0	1			

SW NO.	DATA NO.	ITEM	Switch setting and function						Initial setting	Remarks		
			1			0						
SW32	1	The third priority cassette		None	Tray	1st. Cass.	2nd. Cass.	Tray	0	OPTION It is effective only when No.31-1/2 are set up of manual		
	2		No. 1	0	0	0	0	Other				
	3		No. 2	0	0	1	1	Combination				
	4		No. 3	0	1	0	1					
	5	Reserved							0			
	6	Reserved							0			
	7	Reserved							0			
	8	Print hold function	On			Off			0			
SW33	1	Heater mode		Always on		Always off		0	OPTION			
	2		No. 1	0	0							
	3	Density adjustment of print bias	Binary input 4 2 1						1	set to 1~6. set to 0, is equal to 4 (100).		
	4		No. = 3 4 5 (Data No.) 1: faint ~ 6: deep									
	5		EX 1 0 0 eg. Bias is set to level 4.									
	6	Drum life limit	Near	19000pcs	15000pcs	15000pcs	16000pcs	0				
	7		Limit	20000pcs	16000pcs	20000pcs	20000pcs					
	8		No. 6	0	0	1	1					
9	Reserved							0				
SW34	1	The default resolution for copying	Super fine			Fine		0	OPTION			
	2	Reserved						0				
	3	Reserved						0				
	4	Reserved						0				
	5	Reserved						0				
	6	Reserved						0				
	7	Reserved						0				
	8	Reserved						0				
SW35	1	Reserved						0				
	2	Reserved						1				
	3	Reserved						1				
	4	Reserved						1				
	5	Reserved						0				
	6	Reserved						1				
	7	Reserved						1				
	8	Reserved						0				
SW36	1	Reserved						0				
	2	Reserved						0				
	3	Reserved						1				
	4	Reserved						0				
	5	Reserved						0				
	6	Reserved						0				
	7	Reserved						0				
	8	Reserved						1				
SW37	1	Delay time after PC printing (n second)	Binary input 128 64 32 16 8 4 2 1								0	
	2		No. = 1 2 3 4 5 6 7 8 (Data No.)								0	
	3		EX 0 0 0 0 0 1 1 0 (= 6 secs)								0	
	4									0		
	5									0		
	6									1		
	7									1		
	8									0		

SW NO.	DATA NO.	ITEM	Switch setting and function		Initial setting	Remarks	
			1	0			
SW38	1	Reserved			0		
	2	Reserved			0		
	3	Reserved			0		
	4	Reserved			0		
	5	Reserved			0		
	6	Reserved			0		
	7	Reserved			0		
	8	Reserved			0		
SW39	1	Reserved			0		
	2	Reserved			0		
	3	Reserved			0		
	4	Reserved			0		
	5	Reserved			0		
	6	Reserved			0		
	7	Reserved			0		
	8	Reserved			0		
SW40	1	Reserved			0		
	2	Reserved			0		
	3	Reserved			0		
	4	Reserved			0		
	5	Reserved			0		
	6	Reserved			0		
	7	Reserved			0		
	8	Reserved			0		
SW41	1	Reserved			0		
	2	Reserved			0		
	3	Reserved			0		
	4	Reserved			0		
	5	Reserved			0		
	6	Reserved			0		
	7	Reserved			0		
	8	Reserved			0		
SW42	1	Reserved			0		
	2	Reserved			0		
	3	Reserved			0		
	4	Reserved			0		
	5	Reserved			0		
	6	Reserved			0		
	7	Reserved			0		
	8	Reserved			0		
SW43	1	Reserved			0		
	2	Reserved			0		
	3	Reserved			0		
	4	Reserved			0		
	5	Reserved			0		
	6	Data reduction (Prohibition of setting except Auto and 100%)		AUTO	100%	0	
	7		No. 6	0	1	0	
	8		No. 7	0	0	0	
		No. 8	0	0	0		
SW44	1	Automatic printing of activity report	Yes (When memory full)	No (First data is cleared when memory full)	0	OPTION	
	2	Print out of total time and total number of pages on activity report	Off	On	0		
	3	Reserved			0		
	4	Department function	On	Off	0		
	5	Department ID digit	Binary input	8 4 2 1	0	OPTION	
	6		No. =	5 6 7 8 (Data No.)	1	set to 3 ~ 9	
	7		EX	0 1 0 0	0		
	8		eg. Department is set to level 4.		0		

SW NO.	DATA NO.	ITEM	Switch setting and function					Initial setting	Remarks	
			1		0					
SW45	1	Picture quality priority mode	Fine		standard			0	OPTION	
	2	Cut off mode (When copy mode)	Continue		Cut -off			0	OPTION	
	3	Scanning ratio in memory input	1:1		Reduce			0	Memory Scanning	
	4	Overseas communication mode selection function	Yes		No			0		
	5	Reserved						0		
	6	Reduce ratio when copy mode (Prohibition of setting except Auto and 100%)			AUTO	100%		1		
	7		No. 6	0	1	0				
	8		No. 7	0	0	0				
SW46	1	Reserved						0		
	2	Reserved						0		
	3	Density adjustment (when Fine/STD mode)			Normal	Faint	Deep	0		
	4		No. 3	0	0	1	1			
	5	Density adjustment (when Half-tone mode)			Normal	Faint	Deep	0		
	6		No. 4	0	1	0	1			
	7	MTF correction in Half-tone mode	On		Off			1		
	8	MTF intensity in Half-tone mode	Strong		Weak			0		
SW47	1	Cassette define LTR/A4:Tray	A4		LTR			0		
	2	Cassette define LTR/A4:Upper	A4		LTR			0		
	3	Cassette define LTR/A4:Lower	A4		LTR			0		
	4	Reserved						0		
	5	Reserved						0		
	6	Reserved						0		
	7	Reserved						0		
	8	Reserved						0		
SW48	1	Reserved						1		
	2	Reserved						0		
	3	Reserved						0		
	4	Reserved						0		
	5	Reserved						0		
	6	Reserved						0		
	7	Reserved						0		
	8	Reserved						1		
SW49	1	Secure billing code	Yes		No			0		
	2	Pause with Z key	Yes		No			0		
	3	Reserved						0		
	4	Z key pause time (250ms unit)	Binary input		16	8	4	2	1	0
	5		No. =		4	5	6	7	8	(Data No.)
	6		EX		0	0	0	0	0	0
	7		eg. Pause time 250ms							0
	8	time = (n+1) x 250ms							0	
SW50	1	Separate feature	On		Off			0		
	2	Reserved						0		
	3	Reserved						0		
	4	Reserved						0		
	5	Addition of header (sender information)	On		Off			1		
	6	DTMF sending by the panel test	On		Off			0		
	7	Power save system	Real time		Timer			1		
	8	Reserved						0		

SW NO.	DATA NO.	ITEM	Switch setting and function		Initial setting	Remarks
			1	0		
SW51	1	Reserved			0	
	2	Reserved			0	
	3	Reserved			0	
	4	Reserved			0	
	5	Reserved			0	
	6	Reserved			0	
	7	Reserved			0	
	8	Reserved			0	
SW52	1	Reserved			0	
	2	Reserved			0	
	3	Reserved			0	
	4	Reserved			0	
	5	Reserved			0	
	6	Reserved			0	
	7	Reserved			0	
	8	Reserved			0	
SW53	1	Reserved			0	
	2	Reserved			0	
	3	Reserved			0	
	4	Reserved			0	
	5	Reserved			0	
	6	Reserved			0	
	7	Reserved			0	
	8	Reserved			0	
SW54	1	Reserved			0	
	2	Reserved			0	
	3	Reserved			0	
	4	Reserved			0	
	5	Reserved			0	
	6	Reserved			0	
	7	Reserved			0	
	8	Reserved			0	
SW55	1	Reserved			0	
	2	Reserved			0	
	3	Reserved			0	
	4	Reserved			0	
	5	Reserved			0	
	6	Reserved			0	
	7	Reserved			0	
	8	Reserved			0	
SW56	1	Reserved			0	
	2	Reserved			0	
	3	Reserved			0	
	4	Reserved			0	
	5	Reserved			0	
	6	Reserved			0	
	7	Reserved			0	
	8	Reserved			0	
SW57	1	Reserved			0	
	2	Reserved			0	
	3	Reserved			0	
	4	Reserved			0	
	5	Reserved			0	
	6	Reserved			0	
	7	Reserved			0	
	8	Reserved			0	

SW NO.	DATA NO.	ITEM	Switch setting and function		Initial setting	Remarks
			1	0		
SW58	1	Reserved			0	
	2	Reserved			0	
	3	Reserved			0	
	4	Reserved			0	
	5	Reserved			0	
	6	Reserved			0	
	7	Reserved			0	
	8	Reserved			0	
SW59	1	Reserved			0	
	2	Reserved			0	
	3	Reserved			0	
	4	Reserved			0	
	5	Reserved			0	
	6	Reserved			0	
	7	Reserved			0	
	8	Reserved			0	
SW60	1	Reserved			0	
	2	Reserved			0	
	3	Reserved			0	
	4	Reserved			0	
	5	Reserved			0	
	6	Reserved			0	
	7	Reserved			0	
	8	Reserved			0	
SW61	1	Reserved			0	
	2	Reserved			0	
	3	Reserved			1	
	4	Reserved			0	
	5	Reserved			0	
	6	Reserved			1	
	7	Reserved			0	
	8	Reserved			1	
SW62	1	Reserved			0	
	2	Reserved			0	
	3	Reserved			0	
	4	Reserved			0	
	5	Reserved			0	
	6	Reserved			0	
	7	Reserved			0	
	8	Reserved			0	
SW63	1	Reserved			0	
	2	Reserved			1	
	3	Waiting time after dialing	90 sec	Depends on each country's specifications	0	
	4	Reserved			0	
	5	Reserved			0	
	6	Reserved			0	
	7	Reserved			0	
	8	Reserved			0	

SW NO.	DATA NO.	ITEM	Switch setting and function		Initial setting	Remarks
			1	0		
SW64	1	Reserved			0	
	2	Reserved			0	
	3	Reserved			0	
	4	Reserved			0	
	5	Reserved			0	
	6	Reserved			0	
	7	Reserved			0	
	8	Reserved			0	
SW65	1	Reserved			0	
	2	Reserved			0	
	3	Reserved			0	
	4	Reserved			0	
	5	Reserved			0	
	6	Reserved			0	
	7	Reserved			0	
	8	Reserved			0	
SW66	1	Reserved			0	
	2	Reserved			0	
	3	Reserved			0	
	4	Reserved			0	
	5	Reserved			1	
	6	Reserved			1	
	7	Reserved			0	
	8	Reserved			1	
SW67	1	Reserved			0	
	2	Reserved			0	
	3	Reserved			0	
	4	Reserved			0	
	5	Reserved			0	
	6	Reserved			0	
	7	Reserved			0	
	8	Reserved			0	
SW68	1	Reserved			0	
	2	Reserved			0	
	3	Reserved			0	
	4	Reserved			0	
	5	Reserved			0	
	6	Reserved			0	
	7	Reserved			0	
	8	Reserved			0	
SW69	1	Reserved			0	
	2	Reserved			0	
	3	Reserved			0	
	4	Reserved			0	
	5	Reserved			0	
	6	Reserved			0	
	7	Reserved			0	
	8	Reserved			0	
SW70	1	Reserved			0	
	2	Reserved			0	
	3	Reserved			0	
	4	Reserved			0	
	5	Reserved			0	
	6	Reserved			0	
	7	Reserved			0	
	8	Reserved			0	

SW NO.	DATA NO.	ITEM	Switch setting and function		Initial setting	Remarks
			1	0		
SW71	1	Reserved			0	
	2	Reserved			0	
	3	Reserved			0	
	4	Reserved			0	
	5	Reserved			0	
	6	Reserved			0	
	7	Reserved			0	
	8	Reserved			0	
SW72	1	Reserved			0	
	2	Reserved			0	
	3	Reserved			0	
	4	Reserved			0	
	5	Reserved			0	
	6	Reserved			0	
	7	Reserved			0	
	8	Reserved			0	
SW73	1	Reserved			0	
	2	Reserved			0	
	3	Reserved			0	
	4	Reserved			0	
	5	Reserved			0	
	6	Reserved			0	
	7	Reserved			0	
	8	Reserved			0	
SW74	1	Reserved			0	
	2	Reserved			0	
	3	Reserved			0	
	4	Reserved			0	
	5	Reserved			0	
	6	Reserved			0	
	7	Reserved			0	
	8	Reserved			0	
SW75	1	Reserved			0	
	2	Reserved			0	
	3	Reserved			0	
	4	Reserved			0	
	5	Reserved			0	
	6	Reserved			0	
	7	Reserved			0	
	8	Reserved			0	
SW76	1	Reserved			0	
	2	Reserved			0	
	3	Reserved			0	
	4	Reserved			0	
	5	Reserved			0	
	6	Reserved			0	
	7	Reserved			0	
	8	Reserved			0	
SW77	1	Reserved			0	
	2	Reserved			0	
	3	Reserved			0	
	4	Reserved			0	
	5	Reserved			0	
	6	Reserved			0	
	7	Reserved			0	
	8	Reserved			0	

SW NO.	DATA NO.	ITEM	Switch setting and function		Initial setting	Remarks
			1	0		
SW78	1	Reserved			0	
	2	Reserved			0	
	3	Reserved			0	
	4	Reserved			0	
	5	Reserved			0	
	6	Reserved			0	
	7	Reserved			0	
	8	Reserved			0	
SW79	1	Reserved			0	
	2	Reserved			0	
	3	Reserved			0	
	4	Reserved			0	
	5	Reserved			0	
	6	Reserved			0	
	7	Reserved			0	
	8	Reserved			0	
SW80	1	Reserved			0	
	2	Reserved			0	
	3	Reserved			0	
	4	Reserved			0	
	5	Reserved			0	
	6	Reserved			0	
	7	Reserved			0	
	8	Reserved			0	
SW81	1	Reserved			0	
	2	Reserved			0	
	3	Reserved			0	
	4	Reserved			0	
	5	Reserved			0	
	6	Reserved			0	
	7	Reserved			0	
	8	Reserved			0	
SW82	1	Reserved			0	
	2	Reserved			0	
	3	Reserved			0	
	4	Reserved			0	
	5	Reserved			0	
	6	Reserved			0	
	7	Reserved			0	
	8	Reserved			0	
SW83	1	Reserved			0	
	2	Reserved			0	
	3	Reserved			0	
	4	Reserved			0	
	5	Reserved			0	
	6	Reserved			0	
	7	Reserved			0	
	8	Reserved			0	
SW84	1	Reserved			0	
	2	Reserved			0	
	3	Reserved			0	
	4	Reserved			0	
	5	Reserved			0	
	6	Reserved			0	
	7	Reserved			0	
	8	Reserved			0	

SW NO.	DATA NO.	ITEM	Switch setting and function		Initial setting	Remarks
			1	0		
SW85	1	Reserved			0	
	2	Reserved			0	
	3	Reserved			0	
	4	Reserved			0	
	5	Reserved			0	
	6	Reserved			0	
	7	Reserved			0	
	8	Reserved			0	
SW86	1	Reserved			0	
	2	Reserved			0	
	3	Reserved			0	
	4	Reserved			0	
	5	Reserved			0	
	6	Reserved			0	
	7	Reserved			0	
	8	Reserved			0	
SW87	1	Reserved			0	
	2	Reserved			0	
	3	Reserved			0	
	4	Reserved			0	
	5	Reserved			0	
	6	Reserved			0	
	7	Reserved			0	
	8	Reserved			0	
SW88	1	Reserved			0	
	2	Reserved			0	
	3	Reserved			0	
	4	Reserved			0	
	5	Reserved			0	
	6	Reserved			0	
	7	Reserved			0	
	8	Reserved			0	
SW89	1	Reserved			0	
	2	Reserved			0	
	3	Reserved			0	
	4	Reserved			0	
	5	Reserved			0	
	6	Reserved			0	
	7	Reserved			0	
	8	Reserved			0	
SW90	1	Reserved			0	
	2	Reserved			0	
	3	Reserved			0	
	4	Reserved			0	
	5	Reserved			0	
	6	Reserved			0	
	7	Reserved			0	
	8	Reserved			0	

SW NO.	DATA NO.	ITEM	Switch setting and function		Initial setting	Remarks
			1	0		
SW91	1	Reserved			0	
	2	Reserved			0	
	3	Reserved			0	
	4	Reserved			0	
	5	Reserved			0	
	6	Reserved			0	
	7	Reserved			0	
	8	Reserved			0	
SW92	1	Reserved			0	
	2	Reserved			0	
	3	Reserved			0	
	4	Reserved			0	
	5	Reserved			0	
	6	Reserved			0	
	7	Reserved			0	
	8	Reserved			0	
SW93	1	Reserved			0	
	2	Reserved			0	
	3	Reserved			0	
	4	Reserved			0	
	5	Reserved			0	
	6	Reserved			0	
	7	Reserved			0	
	8	Reserved			0	
SW94	1	Reserved			0	
	2	Reserved			0	
	3	Reserved			0	
	4	Reserved			0	
	5	Reserved			0	
	6	Reserved			0	
	7	Reserved			0	
	8	Reserved			0	
SW95	1	Reserved			0	
	2	Reserved			0	
	3	Reserved			0	
	4	Reserved			0	
	5	Reserved			0	
	6	Reserved			0	
	7	Reserved			0	
	8	Reserved			0	
SW96	1	Reserved			0	
	2	Reserved			0	
	3	Reserved			0	
	4	Reserved			0	
	5	Reserved			0	
	6	Reserved			0	
	7	Reserved			0	
	8	Reserved			0	

SW NO.	DATA NO.	ITEM	Switch setting and function		Initial setting	Remarks
			1	0		
SW97	1	Reserved			0	
	2	Reserved			0	
	3	Reserved			0	
	4	Reserved			0	
	5	Reserved			0	
	6	Reserved			0	
	7	Reserved			0	
	8	Reserved			0	
SW98	1	Reserved			0	
	2	Reserved			0	
	3	Reserved			0	
	4	Reserved			0	
	5	Reserved			0	
	6	Reserved			0	
	7	Reserved			0	
	8	Reserved			0	
SW99	1	Reserved			0	
	2	Reserved			0	
	3	Reserved			0	
	4	Reserved			0	
	5	Reserved			0	
	6	Reserved			0	
	7	Reserved			1	
	8	Reserved			1	

• Soft switch function description

SW1 No. 1 ~ No. 4 Recall interval

Choice is made for a recall interval for speed and rapid dial numbers. Use a binary number to program this. If set to 0 accidentally, 1 will be assumed.

SW1 No. 5 ~ No. 8 Recall times

Choice is made as to how many recall times should be made. Use a binary number to program this.

SW2 No. 1 Dial mode

Switch the type according to the telephone circuit connected to the facsimile.

- 0: PULSE DIAL
- 1: TONE DIAL

SW2 No. 2 Receive mode

Auto/manual receiving mode is set.

SW2 No. 3 ECM mode

Used to determine ECM mode function. Refer to the following table.

SW2 No. 4 Reserved

Set to "0".

SW2 No. 5 Polling security

This switch is employed to enable or disable the polling operation using the ID code verification function, in order to prevent unauthorized polling operation.

SW2 No. 6 Auto cover sheet

When "1" (=YES) is selected, the cover sheet is automatically sent after transmission of the original to notify the receiver of the number of original sheets transmitted.

SW2 No. 7 JUNK-FAX function in manual reception

It is set whether JUNK-FAX is functioned in the manual receiving mode or not.

SW2 No. 8 JUNK-FAX function

This function is used to receive data from a specific remote machine (station registered in entry mode). It is the function that refused a reception in the case that TSI of remote machine matched with fax number of the station registered.

- 0: No
- 1: Yes

SW3 No. 1 ~ No. 4 Number of rings for auto-receive (0: No ring receive)

When the machine is set in the auto receive mode, the number of rings before answering can be selected. It may be set from one to nine rings using a binary number. If the soft switch was set to 1, a direct connection is made to the facsimile. If it was set to 0 accidentally, receive ring is set to 1. If it was above 9, receive rings are set to 9.

SW3 No. 5 ~ No. 8 Switch to auto-receive from manual receive (0: No switch)

This setting allows machine to switch from manual to Auto Receive mode. Setting this number to 0 forces machine to stay in Manual receive mode. Entering the binary number 0 forces the machine to remain in the manual answer mode. If a number between 1 and 9 is entered, the machine will go into the answer mode after the given number of rings. However, it can be used as an ordinary telephone if the handset is taken off the hook before this programmed number is finished. If entry of a number above 9 by accident, it will be set to 9. In this case, it must be corrected to the proper number.

SW4 No. 1 ~ No. 3 Communication results printout

It is possible to obtain communication results after each transaction. Normally, the switch is set (No. 1: 0, No. 2: 0, No. 3: 1) so that the communication result is produced only a communication error is encountered. If No. 1 was set to 1, No. 2 was set to 1 and No. 3 was set to 0, the communication result will be produced every time a communication is done, even if the communication was successful.

If No. 1 was set to 0, No. 2 to 1 and No. 3 to 0, the communication result will be produced every transmission.

Setting No. 1 to 1 No. 2 to 0 and No. 3 to 0 will disable this function. No transaction report will be printed.

If No. 1 was set to 0, No. 2 to 0 and No. 3 to 0, the communication result is produced only after a timer and memory transmission or when a communication error is encountered.

SW4 No. 4 Image addition function to the communication result table (for memory transmission only)

Used to set addition of sending image to the communication result table.

SW4 No. 5 Reserved

Set to "0".

SW4 No. 6 TEL billing code function

When set to "1", the TEL billing code function is enabled.

SW4 No. 7 Billing code position

When set to "1", the billing code is delivered before dialing the remote number. When set to "0", the billing code is delivered after dialing.

SW4 No. 8 Multi-TTI feature

When this switch is set to "1", Multi TTI function is enabled.

SW5 No. 1 Time display format

When this switch is set to "0", time is displayed in 12-hour system. When set to "1", 24-hour system.

SW5 No. 2 Date display format

Used to select date display/print formats.

- 0: DAY-Month-Year
- 1: Month-DAY-Year

SW5 No. 3 Header print

When it is set at 0, sender's name, sending page number and so on are automatically printed in the recording paper on the receiving side during transmission. Thus, the sender can be known on the receiving side.

- 0: Applied.
- 1: Not applied.

SW5 No. 4 Footer print

When set to "1", the date of reception, the sender machine No., and the page No. are automatically recorded at the end of reception.

SW5 No. 5 Relay data output

- 0: Output ON
- 1: Output OFF

SW5 No. 6 Substitute reception

Selection of substitute reception in the case of recording paper ex-hausted or paper jam. If set to "NO", auto receive is disabled even when the receive memory is ready to receive.

Substitute reception is not performed even during receive operation.

SW5 No. 7 Substitute reception conditions

Selection of substitute reception according to existence of TEL number from transmitting side. Initial setting allows substitute reception without CSI. If set to "no", the receiver cannot receive any documents

SW5 No. 8 CSI transmission

CSI signal contains the sender's phone number registered in the machine. If this switch is set to "1", no sender's name will be printed at the receiving side.

SW6 No. 1 JBIG (Joint Bi-level Image Group)

An image compression encoding method recommended by ITU-T. It realizes 2-second transmission when the power is turned on.

SW6 No. 2 JBIG option

An optional function for JBIG.

SW6 No. 3 MMR

MMR (Modified MR) selects presence of the compression function.

SW6 No. 4 MR

MR (Modified READ) selects presence of the compression function.

SW6 No. 5 ~ No. 8 Modem speed

Used to determine the initial modem speed. The default is 14400BPS(V.17). It may be necessary to program it to a slower speed when frequent line fallback is encountered, in order to save the time required for the fallback procedure.

SW7 No. 1, No. 2 Reception speed fixed

The transferable speed of modem in the receiving mode is set.

SW7 No. 3 DIS receive acknowledge during G3 transmission

Used to make a choice of whether reception of NSF (DIS) is acknowledged after receiving two NSFs (DISs) or receiving one NSF (two DISs). It may be useful for overseas communication to avoid an echo suppression problem, if set to 1.

SW7 No. 4 Non-modulated carrier in V.29 transmission mode

Though transmission of a non-modulated carrier is not required for transmission by the V29 modem according to the CCITT Recommendation, it may be permitted to send a non-modulated carrier before the image signal to avoid an echo suppression problem.

It may be useful for overseas communication to avoid an echo suppression problem, if set to 1.

SW7 No. 5 CNG send in manual transmission

CNG signal sending ON/OFF in case of manual transmission is set.

SW7 No. 6 Protocol monitor

Normally set to "0". If set to "1", communication can be checked, in case of troubles, without using a G3 tester or other tools.

When communication FSK data transmission or reception is made, the data is taken into buffer. When communication is finished, the data analyzed and printed out. When data is received with the line monitor (SW7-No. 7) set to "1" the reception level is also printed out.

SW7 No. 7 Line monitor

Normally set to "0". If set to "1", the transmission speed and the reception level are displayed on the LCD. Used for line tests.

SW7 No. 8 Max. length for TX/RX/Copy

Used to set the maximum page length.

To avoid possible paper jam, the page length is normally limited to 432 mm for copy or transmit, and 1.5 meters for receive.

It is possible to set it to "No limit" to transmit/receive a long document, such as a computer print form, etc. (In this case, the receiver/transmitter must also be set to no limit.)

SW8 No. 1, No. 2 Compromised equalizer

The specific line equalizer is inserted.

No. 1 No. 2

0	0	The line equalizer built in the modem is turned off.
0	1	Line equalizer corresponding to 1.8 km
1	0	Line equalizer corresponding to 3.6 km
0	1	Line equalizer corresponding to 7.2 km

SW8 No. 3 H2 mode

Used to determine H2 mode (15sec transmission mode). When set to OFF, H2 mode is inhibited even though the transmitting machine has H2 mode.

SW8 No. 4 ~ No. 8 Signal transmission level

Used to control the signal transmission level in the range of -0dB to -31dB.

SW9 No. 1, No. 2 CED tone signal interval

For international communication, the 2100Hz CED tone may act as an echo suppresser switch, causing a communication problem. Though this soft switch is normally set to "0", it should be set to "1" so as to change the time between CED tone and DIS signal from 75ms to 500ms to eliminate the communication problem caused by echo.

SW9 No. 3 Equalization freeze

This switch is used to perform reception operation by fixing the equalizer control of modem for the line which is always in an unfavorable state and picture cannot be received. Usually, the control is executed according to the state of line where the equalizer setting is changed always.

SW9 No. 4 Equalization freeze conditions

Setting which specifies SW9 No.3 control only in condition of 7200bps modem speed.

SW9 No. 5 CED detection time

The detection time of the CED signal from the called side in the auto calling mode is set.

SW9 No. 6, No. 7 Alarm buzzer

The length of the buzzer for normal end of operation is set.

SW9 No. 8 Action when RTN received

The operation is set when the RTN signal is received in the G3 transmission mode.

SW10 No. 1 ~ No. 4 Memory retransmission times

The number of memory retransmissions is set.

SW10 No. 5 ~ No. 8 Memory retransmission interval

The interval between memory retransmissions is set.

SW11 No. 1 ~ No. 3 Reserved

Set to "1".

SW11 No. 4 Reserved

Set to "0".

SW11 No. 5 ~ No. 7 Reserved

Set to "1".

SW11 No. 8 Reserved

Set to "0".

SW12 No. 1, No. 2 Reserved

Set to "1".

SW12 No. 3 Reserved

Set to "0".

SW12 No. 4, No. 5 EOL detection timer

Used to make a choice of whether to use the 25-second or 13-second timer for detection of End of line This is effective to override communication failures with some facsimile models that have longer End of line detection.

SW12 No. 6, No. 7 Processing of DIS reception after DIS transmission

When receiving , operation in case of DIS reception after DIS transmission is selected.

Retransmitting command: To retransmit DIS in disregard of DIS reception.

Breaking circuit: To break circuit instantly. (Abnormal finish)

T. 30: To operate in accordance with T.30.

T. 30+α: To operate in accordance with T.30+α. (To operate differently according to cases.)

SW12 No. 8 The change to DB from DP by ✕

When setting to 1, the mode is changed by pressing the ✕ key from the pulse dial mode to the tone dial mode.

SW13 No. 1 ~ No. 5 DTMF output level (High)

To set the level to output high group DTMF signals. -15 to 0 dBm (0.5 dBm unit)

SW13 No. 6 ~ No. 8 Reserved

Set to "0".

SW14 No. 1 ~ No. 5 DTMF output level (Low)

To set the level to output low group DTMF signals. -15 to 0 dBm (0.5 dBm unit)

SW14 No. 6 ~ No. 8 Reserved

Set to "0".

SW15 No. 1 ~ No. 8 Reserved

Set to "0".

SW16 No. 1 ~ No. 4 Reserved

Set to "0".

SW16 No. 5 ~ No. 8 CI signal OFF detect enable time

Used to set the continuous detection time during OFF period of CI signal.

SW17 No. 1 ~ No. 4 Reserved

Set to "0".

SW17 No. 5 ~ No. 8 Distinctive ringing

When the ringing setting is turned off, all of the CI signal are received. When any of the standard, and ring patterns 1 through 3 is selected for the ringing setting, only the selected CI signal is received.

CI signal patterns

The CI signal patterns consists of the standard pattern, and ring patterns 1 through 7. The standard pattern is the conventional one.

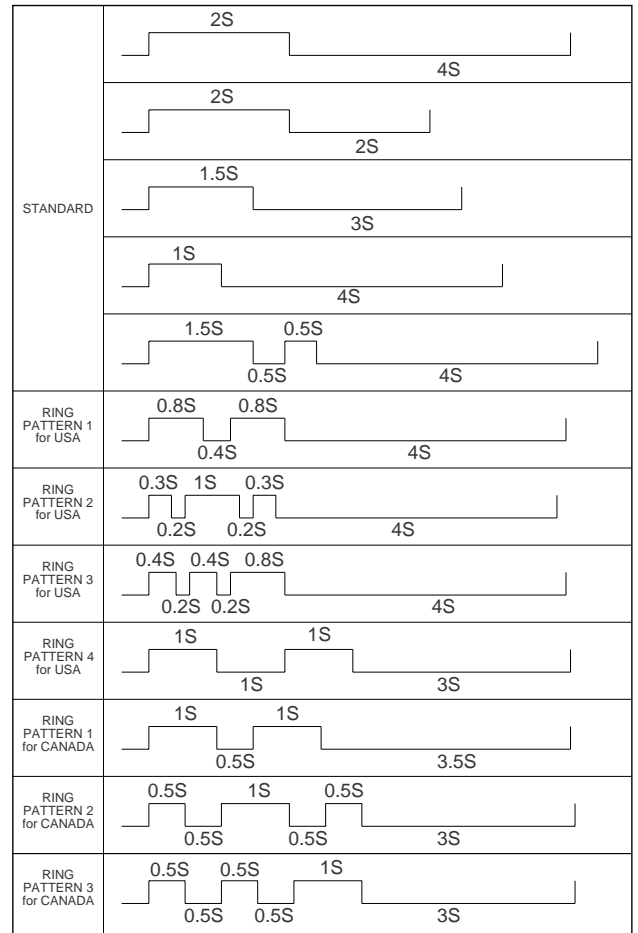

SW18 No. 1 ~ No. 8 Reserved

Set to "0".

SW19 No. 1 ~ No. 3 Reserved

Set to "0".

SW19 No. 4 , No. 5 Reserved

Set to "1".

SW19 No. 6 ~ No. 8 Reserved

Set to "0".

SW20 No. 1 , No. 2 Reserved

Set to "0".

SW20 No. 3 , No. 4 Reserved

Set to "1".

SW20 No. 5 ~ No. 8 Reserved

Set to "0".

SW21 No. 1 Reserved

Set to "1".

SW21 No. 2 ~ No. 4 Reserved

Set to "0".

SW21 No. 5 Reserved

Set to "1".

SW21 No. 6 ~ No. 8 Reserved

Set to "0".

SW22 No. 1 ~ No. 8 Reserved

Set to "0".

SW23 No. 1 ~ No. 3 Reserved

Set to "0".

SW23 No. 4 ~ No. 6 Busy tone detection frequency

To select frequency range of signals to be detected as Busy Tone.

SW23 No. 7, No. 8 Reserved

Set to "0".

SW24 No. 1 ~ No. 8 Reserved

Set to "0".

SW25 No. 1 ~ No. 8 Reserved

Set to "0".

SW26 No. 1 ~ No. 8 Reserved

Set to "0".

SW27 No. 1 F.A.S.T (RMS) mode

Used to determine a function of remote maintenance system (F.A.S.T).

SW27 No. 2 Reserved

Set to "0".

SW27 No. 3 Verification STAMP

End stamp:

It is set whether the red round mark is stamped at the bottom margin of the document of every page in the memory input mode and document sending mode or not.

SW27 No. 4 Summer time (Day light saving)

The day light saving function ON/OFF is set.

SW27 No. 5, No. 6 Key buzzer volume

Key buzzer volume:

The sound volume of key inputting buzzer and other buzzers is set.

SW27 No. 7, No. 8 Reserved

Set to "0".

SW28 No. 1, No. 2 Speaker volume

Speaker volume:

The sound volume of the speaker in the on-hook mode is set.

SW28 No. 3 Reserved

Set to "1".

SW28 No. 4 Reserved

Set to "0".

SW28 No. 5, No. 6 Ringer volume

Ringer volume:

The calling sound volume of CI signal receiving is set.

SW28 No. 7, No. 8 Reserved

Set to "0".

SW29 No. 1 Reserved

Set to "0".

SW29 No. 2 PC I/F mode

The interface with the personal computer is selected.

SW29 No. 3 ~ No. 8 Reserved

Set to "0".

SW30 No. 1 Header registration

When setting this switch to "1", registering senders is protected.

SW30 No. 2 ~ No. 7 Reserved

Set to "0".

SW30 No. 8 Quick on-line function

It is selected whether auto dial call is activated in the memory input mode when one document is completely read or when all pages are completely read.

SW31 No. 1, No. 2 Cassette selection

To set selective modes for detail paper cassettes of the printer.

00:	Manual	To select detail paper in the first priority cassette in accordance with setting by SW31 3-8 and SW32 1-3. If the detail paper in the first priority cassette runs short, the second priority cassette will be used.
01:	Automatic 1	To automatically select detail paper with optimum size among the first to third priority cassettes in accordance with setting by SW31 3-8 and SW32 1-3. The optimum paper is selected by every page. If all the cassettes have the same size paper, paper will be selected according to the cassette priority.
10:	Automatic 2	To automatically select detail paper with optimum size among the first to third priority cassettes in accordance with setting by SW31 3-8 and SW32 1-3. At the start of printing, the optimum paper is adopted only for the first page. Thereafter the same cassette selected for the first page will be used from the second page and after. If all the cassettes have the same size paper, paper will be selected according to the cassette priority.
11:	Except the above	Setting forbidden (01: the same setting as in the case of Automatic 1)

SW31 No. 3 ~ No. 5 The first priority cassette

To select the first priority cassette.

001:	1st paper feeder (MP-TRAY)
010:	2nd paper feeder
011:	3rd paper feeder
Except the above	Setting forbidden (Printing started from the possible paper feeder)

SW31 No. 6 ~ No. 8 The second priority cassette

To select the second priority cassette.

000:	Not used (To set in case of using only paper feeder that has been set in the first priority cassette)
001:	1st paper feeder (MP-TRAY)
010:	2nd paper feeder
011:	3rd paper feeder
Except the above	Setting forbidden (Not used)

SW32 No. 1 ~ No. 3 The third priority cassette

To select the third priority cassette.

000:	Not used (To set in case of using only paper feeder that has been set in the first /second priority cassette)
001:	1st paper feeder (MP-TRAY)
010:	2nd paper feeder
011:	3rd paper feeder
Except the above	Setting forbidden (Not used)

SW32 No. 4 ~ No. 7 Reserved

Set to "0".

SW32 No. 8 Print hold function

When set to "1", the print hold function is enabled.

SW33 No.1, No. 2 Heater mode

Used to set ON/OFF of the heater. Three settings are available: always ON, always OFF, and OFF timer. (Only when Off timer is selected, SW34-SW37 settings are valid.)

To set performance of the heater at the printer fixing part.

00:	Normally ON (Off in case of Save Mode, giving priority to Energy Save Mode)
01:	Normally OFF
Except the above	Setting forbidden (Normally OFF)

SW33 No. 3 ~ No. 5 Density adjustment of print bias

The density of printing is set.

It can be also set in the print diagnosis mode.

SW33 No. 6, No. 7 Drum life limit

The drum life -over judgment conditions are set.

SW33 No. 8 Reserved

Set to "0".

SW34 No. 1 The default resolution for copying

In case of copying without pressing the RESOLUTION key, resolution will be super fine.

SW34 No. 2 ~ No. 8 Reserved

Set to "0".

SW35 No. 1 Reserved

Set to "0".

SW35 No. 2 ~ No. 4 Reserved

Set to "1".

SW35 No. 5 Reserved

Set to "0".

SW35 No.6, No. 7 Reserved

Set to "1".

SW35 No.8 Reserved

Set to "0".

SW36 No. 1, No. 2 Reserved

Set to "0".

SW36 No. 3 Reserved

Set to "1".

SW36 No. 4 ~ No. 7 Reserved

Set to "0".

SW36 No. 8 Reserved

Set to "1".

SW37 No. 1 ~ No. 8 Delay time after PC printing (n second)

To insert delay time after PC printing.

SW38 No. 1 ~ No. 8 Reserved

Set to "0".

SW39 No. 1 ~ No. 8 Reserved

Set to "0".

SW40 No. 1 ~ No. 8 Reserved

Set to "0".

SW41 No. 1 ~ No. 8 Reserved

Set to "0".

SW42 No. 1 ~ No. 8 Reserved

Set to "0".

SW43 No. 1 ~ No. 5 Reserved

Set to "0".

SW43 No. 6 ~ No. 8 Data reduction

Reduction ratio of receiving is set .

It can be changed even in the optional mode.

To set printing reduction rate of received images.

000:	Automatic
100:	100%
Except the above	100%

SW44 No. 1 Automatic printing of activity report

This soft switch is used to select; whether or not to produce the activity report when the memory is full (about 50 items). An activity report can be produced when the following key entry command is made.

"FUNC", "2", "#", "START"

After producing the activity report, all the data in the memory will be cleared.

When the switch function is set to "0" (NO), the data in memory will be deleted from the oldest as it reaches the maximum memory capacity (approx. 50 items).

SW44 No. 2 Printout of total time and total number of pages on activity report

Used to make a choice of whether the total communication time and pages are recorded in the activity report.

SW44 No. 3 Reserved

Set to "0".

SW44 No. 4 Department function

This model has the department audit feature, it has to be set to 1 to utilize this feature.

SW44 No. 5 ~ No. 8 Department ID digit

Used to set the department ID digit number .
When set to "D" , the number is "4" .

SW45 No. 1 Picture quality priority mode

Used to set the transmission mode which is automatically selected when the MODE key is not pressed. In the copy mode, however, the fine mode is automatically selected unless the MODE key is manually set to another mode.

SW45 No. 2 Cut-off mode (when copy mode)

When in copy, if the scanned data is out of the range of recording, the operator has one of the choices below using the switch.

0: Continue: Data is printed onto the next page with the last 20mm also printed at the beginning of the next page.

1: Cut off: Data scanned out of the limit is cut off (a page is printed.)

SW45 No. 3 Scanning ratio in memory input

In the case of memory transmission, etc., only letter size (A4) documents can be stored in the memory. To input B4 documents into the memory, therefore, the B4 documents must be reduced to letter size (A4) or the both ends of the B4 documents will be cut off to input the center letter-size (A4) portion. This switch provides the selection.

0: Reduced to A4 size and inputted.

1: Both ends are cut off and the center portion (A4 size) is inputted.

SW45 No. 4 Overseas communication mode selection function

When this switch is set to "1", the communication is Super G3 mode can be turned off by pressing the "SPACE" key before sending operation, for the transmission set after that (including polling).

SW45 No. 5 Reserved

Set to "0".

SW45 No. 6 ~ No. 8 Reduce ratio when copy mode

Reduction ratio of copying is set .
It can changed even in the optional mode.

SW46 No. 1, No. 2 Reserved

Set to "0".

SW46 No. 3, No. 4 Density adjustment (when Fine/STD mode)

This is used for density adjustment in fine/standard mode. Adjust the density according to that of frequently used original.

Set to "Dark" for darker reading (either in the auto or the dark mode) of light original. Set to "Light" for lighter reading (either in the auto or the dark mode) of dark original.

Set to "Dark only in dark mode" for darker reading only in the dark mode.

SW46 No. 5, No. 6 Density adjustment (when Half-tone mode)

This is used for density adjustment in the half tone. Setting procedures are the same as SW46 No. 3 and No. 4.

SW46 No. 7 MTF correction in Half-tone mode

In the half tone mode, image area is separated from character area and processed separately to eliminate unclear character transmission. This switch is used to change the criteria of judgement of separation. When "Strong" (= 1) is selected, more area is judged as character area, providing clearer characters.

On the contrary, however, edges of image area may be emphasized.

It is advisable to restrict the use of this function only when clear characters must be transmitted, and to use the function of "Weak" (= 0) for general cases.

SW46 No. 8 MTF intensity in Half-tone mode

This allows selection of MTF correction (dimness correction) in the half tone mode. When "NO" (= 1) is selected, the whole image becomes soft and mild, On the contrary, however, mildness of characters will be reduced. Normally set to "NO" (= 1).

SW47 No. 1 Cassette define LTR / A4:Tray

A4 cassette can be used .

Set "0" or "1" for all of three bits.

Do not change the setting during printing.

SW47 No. 2 Cassette define LTR / A4:Upper

A4 cassette can be used .

Set "0" or "1" for all of three bits.

Do not change the setting during printing.

SW47 No. 3 Cassette define LTR / A4:Lower

A4 cassette can be used .

Set "0" or "1" for all of three bits.

Do not change the setting during printing.

SW47 No. 4 ~ No. 8 Reserved

Set to "0".

SW48 No. 1 Reserved

Set to "1".

SW48 No. 2 ~ No. 7 Reserved

Set to "0".

SW48 No. 8 Reserved

Set to "1".

SW49 No. 1 Secure billing code

When the Tel. Billing Code function is ON, the operation of SECURE BILLING CODE is enabled .

SW49 No. 2 Pause with Z key

The Z key pause time is set.

SW49 No. 3 Reserved

Set to "0".

SW49 No. 4 ~ No. 8 Z key pause time (250ms unit)

The Z key pause time is set.

SW50 No. 1 Separate feature

The separate mode ON/OFF is set.

SW50 No. 2 ~ No. 4 Reserved

Set to "0".

SW50 No. 5 Addition of header (sender information)

ON/OFF of addition of header (sender information) to various list is set.

SW50 No. 6 DTMF sending by the panel test

When ten keys are pressed in the Panel Test Mode of the diagnosis, the corresponding DTMF signals are output.

SW50 No. 7 Power save system

To switch Power Save Mode system either to Real Time or to Timer.

SW50 No. 8 Reserved

Set to "0".

SW51 No. 1 ~ No. 8 Reserved

Set to "0".

SW52 No. 1 ~ No. 8 Reserved

Set to "0".

SW53 No. 1 ~ No. 8 Reserved

Set to "0".

SW54 No. 1 ~ No. 8 Reserved

Set to "0".

SW55 No. 1 ~ No. 8 Reserved

Set to "0".

SW56 No. 1 ~ No. 8 Reserved

Set to "0".

SW57 No. 1 ~ No. 8 Reserved

Set to "0".

SW58 No. 1 ~ No. 8 Reserved

Set to "0".

SW59 No. 1 ~ No. 8 Reserved

Set to "0".

SW60 No. 1 ~ No. 8 Reserved

Set to "0".

SW61 No. 1, No. 2 Reserved

Set to "0".

SW61 No. 3 Reserved

Set to "1".

SW61 No. 4, No. 5 Reserved

Set to "0".

SW61 No. 6 Reserved

Set to "1".

SW61 No. 7 Reserved

Set to "0".

SW61 No. 8 Reserved

Set to "1".

SW62 No. 1 ~ No. 8 Reserved

Set to "0".

SW63 No. 1 Reserved

Set to "0".

SW63 No. 2 Reserved

Set to "1".

SW63 No. 3 Waiting time after dialing

The set up of the call time of the auto dial.
90 sec. or depends on each country's specifications.

SW63 No. 4 ~ No. 8 Reserved

Set to "0".

SW64 No. 1 ~ No. 8 Reserved

Set to "0".

SW65 No. 1 ~ No. 8 Reserved

Set to "0".

SW66 No. 1 ~ No. 4 Reserved

Set to "0".

SW66 No. 5, No. 6 Reserved

Set to "1".

SW66 No. 7 Reserved

Set to "0".

SW66 No. 8 Reserved

Set to "1".

SW67 No. 1 ~ No. 8 Reserved

Set to "0".

SW68 No. 1 ~ No. 8 Reserved

Set to "0".

SW69 No. 1 ~ No. 8 Reserved

Set to "0".

SW70 No. 1 ~ No. 8 Reserved

Set to "0".

SW71 No. 1 ~ No. 8 Reserved

Set to "0".

SW72 No. 1 ~ No. 8 Reserved

Set to "0".

SW73 No. 1 ~ No. 8 Reserved

Set to "0".

SW74 No. 1 ~ No. 8 Reserved

Set to "0".

SW75 No. 1 ~ No. 8 Reserved

Set to "0".

SW76 No. 1 ~ No. 8 Reserved

Set to "0".

SW77 No. 1 ~ No. 8 Reserved

Set to "0".

SW78 No. 1 ~ No. 8 Reserved

Set to "0".

SW79 No. 1 ~ No. 8 Reserved

Set to "0".

SW80 No. 1 ~ No. 8 Reserved

Set to "0".

SW81 No. 1 ~ No. 8 Reserved

Set to "0".

SW82 No. 1 ~ No. 8 Reserved

Set to "0".

SW83 No. 1 ~ No. 8 Reserved

Set to "0".

SW84 No. 1 ~ No. 8 Reserved

Set to "0".

SW85 No. 1 ~ No. 8 Reserved

Set to "0".

SW86 No. 1 ~ No. 8 Reserved

Set to "0".

SW87 No. 1 ~ No. 8 Reserved

Set to "0".

SW88 No. 1 ~ No. 8 Reserved

Set to "0".

SW89 No. 1 ~ No. 8 Reserved

Set to "0".

SW90 No. 1 ~ No. 8 Reserved

Set to "0".

SW91 No. 1 ~ No. 8 Reserved

Set to "0".

SW92 No. 1 ~ No. 8 Reserved

Set to "0".

SW93 No. 1 ~ No. 8 Reserved

Set to "0".

SW94 No. 1 ~ No. 8 Reserved

Set to "0".

SW95 No. 1 ~ No. 8 Reserved

Set to "0".

SW96 No. 1 ~ No. 8 Reserved

Set to "0".

SW97 No. 1 ~ No. 8 Reserved

Set to "0".

SW98 No. 1 ~ No. 8 Reserved

Set to "0".

SW99 No. 1 ~ No. 6 Reserved

Set to "0".

SW99 No. 7, No. 8 Reserved

Set to "1".

[3] Troubleshooting

1. Fax troubleshooting

Refer to the following actions to troubleshoot any of the problems mentioned in 1-4.

- [1] A communication error occurs.
- [2] Image distortion produced.
- [3] Unable to do overseas communication.
- [4] Communication speed slow due to FALLBACK.
 - Increase the transmission level SOFT SWITCH 8-4, 5, 6, 7, 8
May be used in case [1] [2] [3].
 - Decrease the transmission level SOFT SWITCH 8-4, 5, 6, 7, 8
May be used in case [3].

- Apply line equalization SOFT SWITCH 8-1, 2
May be used in all cases.
 - Slow down the transmission speed SOFT SWITCH 6-5, 6, 7, 8
May be used in case [2] [3].
 - Replace the LIU PWB.
May be used in all cases.
 - Replace the control PWB.
May be used in all cases.
- * If transmission problems still exist on the machine, use the following format and check the related matters.

TO: _____ ATT: _____ Ref.No.: _____
 CC: _____ ATT: _____ Date: _____
 FM: _____ Dept: _____
 _____ Sign: _____

***** Facsimile communication problem *****		Ref.No.: _____																					
From: Mr. _____ Fax Tel No.: _____		Date: _____																					
Our customer	Name _____	Tel No. _____																					
	Address _____	Fax No. _____																					
	Contact person _____	Model name _____																					
Other party	Name _____	Tel No. _____																					
	Address _____	Fax No. _____																					
	Contact person _____	Model name _____																					
Problem mode	Line: Domestic / international _____ Mode: G3 _____	Phase: A. B. C. D. _____																					
	Reception / Transmission _____	Automatic reception / Manual reception _____ Automatic dialing / Manual dialing / Others _____																					
Frequency: _____ %	ROM version: _____																						
Confirmation item			Please mark problem with an X No problem is: 0																				
			<table border="1" style="width: 100%; border-collapse: collapse;"> <tr> <td>A1</td><td>A2</td><td>B1</td><td>B2</td><td>C1</td><td>C2</td><td>D1</td><td>D2</td><td>E1</td><td>E2</td> </tr> <tr> <td style="height: 20px;"></td><td></td><td></td><td></td><td></td><td></td><td></td><td></td><td></td><td></td> </tr> </table>	A1	A2	B1	B2	C1	C2	D1	D2	E1	E2										
	A1	A2	B1	B2	C1	C2	D1	D2	E1	E2													
		Transmission level setting is () dB at our customer																					
		Transmission level () dBm Reception level () dBm By level meter at B1 and B2																					
Comment																							
Countermeasure																							
**** Please attach the G3 data and activity report on problem. ****																							

[4] Error code table**1. Communication error code table****G3 Transmission**

Code	Final received signal	Error Condition (Receiver side)
0	Incomplete signal frame	Cannot recognize bit stream after flag
1	NSF, DIS	Cannot recognize DCS signal by echo etc. Cannot recognize NSS signal (FIF code etc)
2	CFR	Disconnects line during reception (carrier missing etc)
3	FTT	Disconnects line by fallback
4	MCF	Disconnects line during reception of multi page Cannot recognize NSS, DCS signal in the case of mode change
5	PIP or PIN	The line is hung up without replying to telephone request from the receiving party.
6	RTN or RTP	Cannot recognize NSS, DCS signal after transmit RTN or RTP signal.
7	No signal or DCN	No response on receiver side or DCN signal received* (transmitter side)
8	–	Owing to error in some page the error could not be corrected although the specified number of error retransmission was attempted.
11	–	Error occurred after or while reception by the remote (receiving) machine was revealed to be impossible.
12	–	Error occurred just after fallback.
13	–	Error occurred after a response to retransmission end command was received.

G3 Reception

Code	Final received signal	Error Condition (Receiver side)
0	Incomplete signal frame	Cannot recognize bit stream after flag
1	NSS, DCS	Cannot recognize CFR or FTT signal Disconnects line during transmission (line error)
2	NSC, DTC	Cannot recognize NSS signal (FIF code etc)
3	EOP	Cannot recognize MCF, PIP, PIN, RTN, RTP signal
4	EOM	Cannot recognize MCF, PIP, PIN, RTN, RTP signal in the case of mode change
5	MPS	The line is hung up without replying to communication request.
6	PR1-Q	Cannot recognize PIP, PIN signal in the case of TALK request
7	No signal or DCN	No response in transmitter (cannot recognize DIS signal) or DCN signal received* (receiver side)
8	–	Error occurred upon completion of reception of all pages.
9	–	Error occurred when mode was changed or Transmission/Reception switching was performed.
10	–	Error occurred during partial page or physical page reception.
11	–	Error occurred after or during inquiry from the remote (transmitting) machine as to whether reception is possible or not.
12	–	Error occurred during or just after fallback.
13	–	Error occurred after the retransmission end command was received.

2. Service call error message

1. HEATER ERROR
2. LASER ERROR
3. POLYGON ERROR
4. FAN ERROR
5. PCU COMM, ERROR

CHAPTER 4. DIAGRAMS

[1] Block diagram

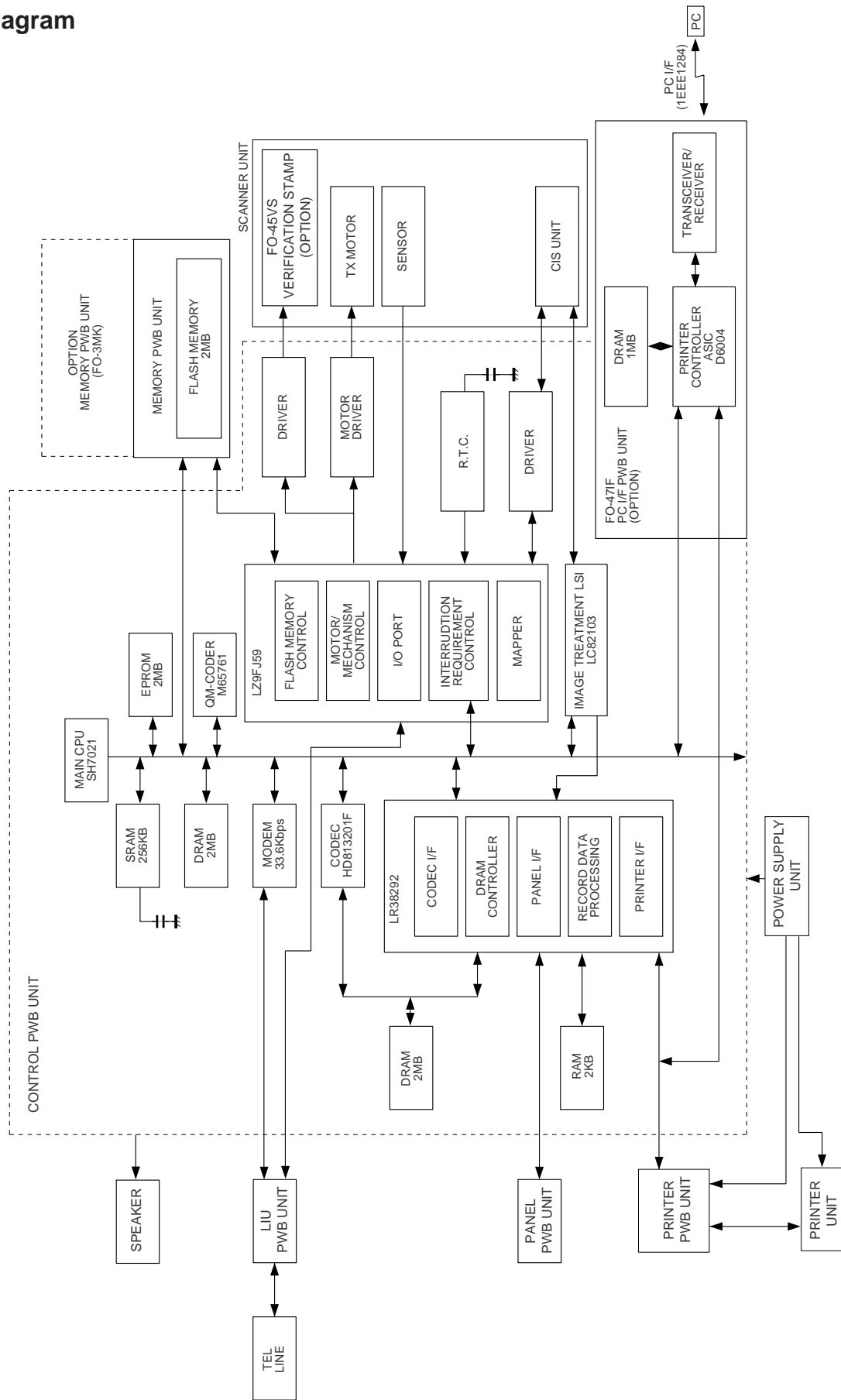

[2] Wiring diagram

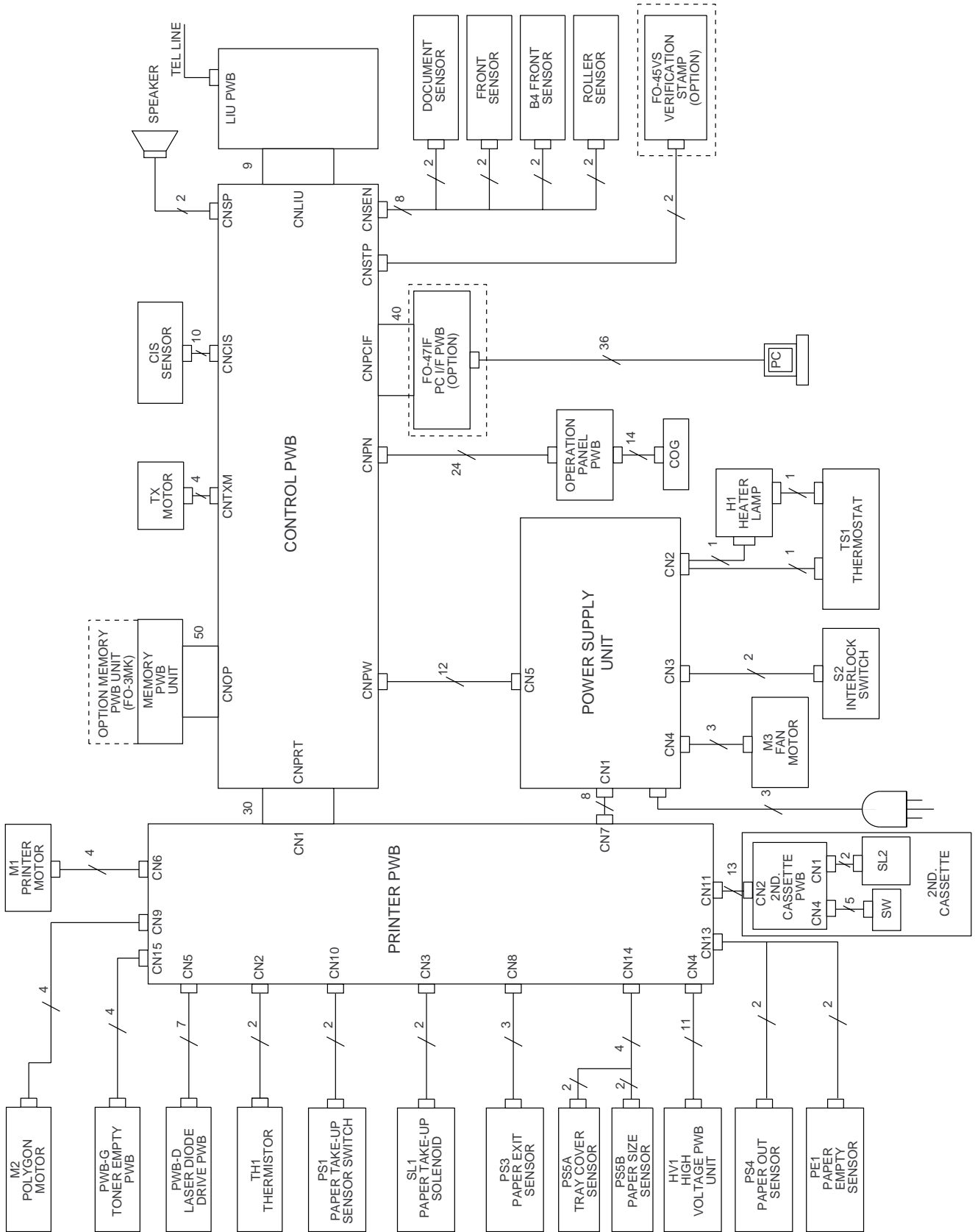

[3] Point- to-point diagram and connector signal name (1)

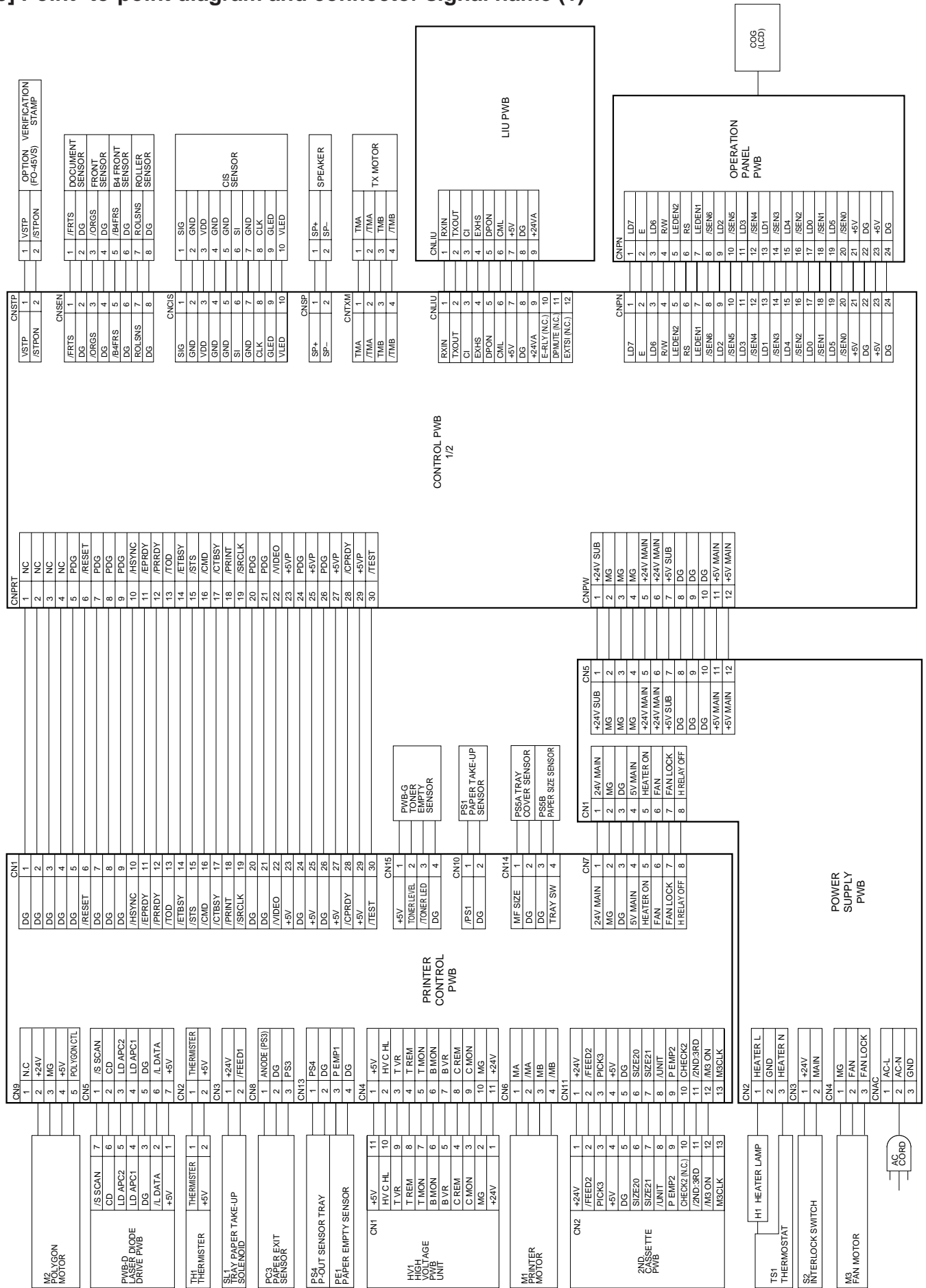

Point- to-point diagram and connector signal name (2)

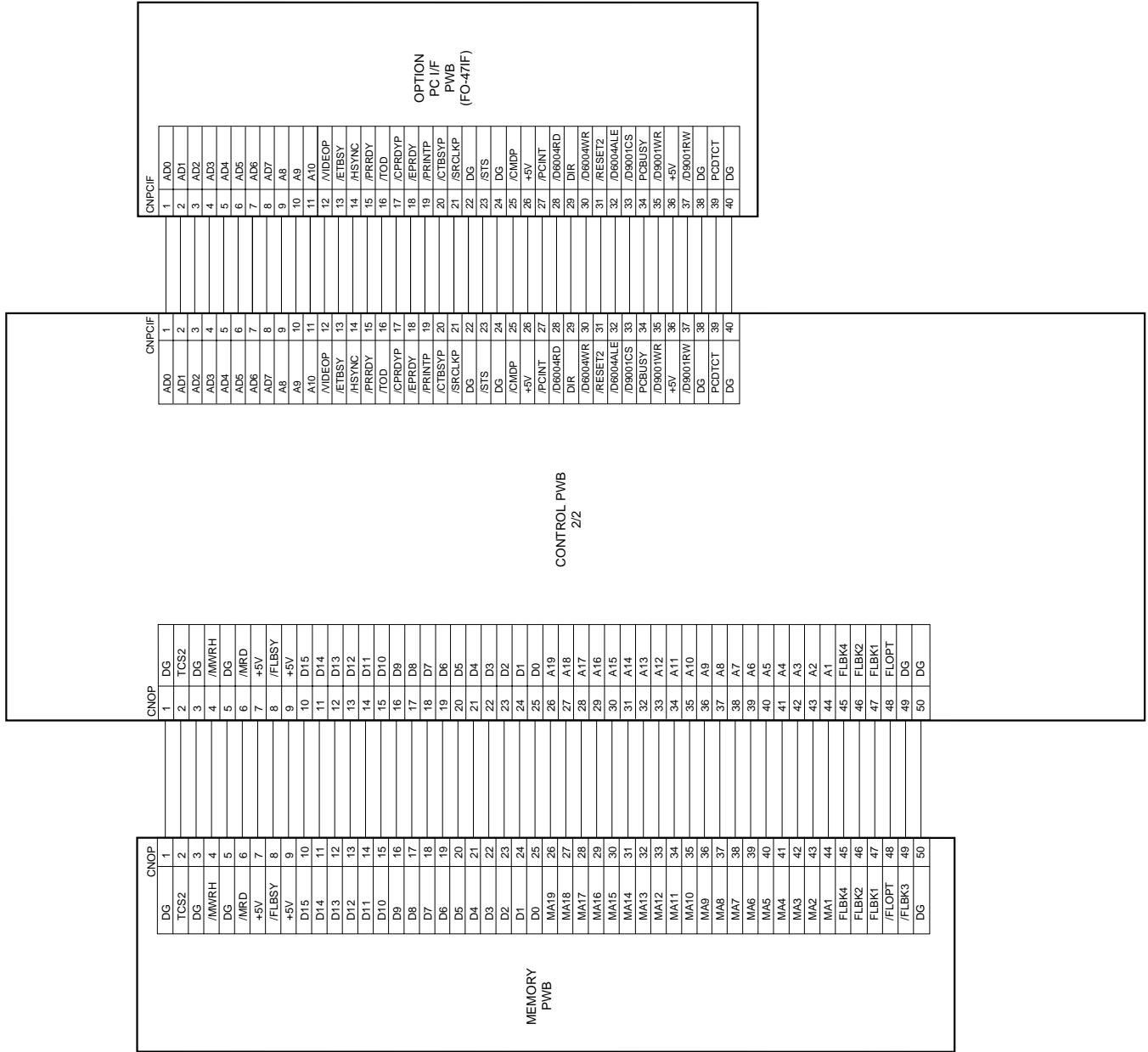

CHAPTER 5. CIRCUIT DESCRIPTION

[1] Circuit description

1. General description

In this machine, the facsimile control block except the printer control is mainly composed of the units shown in Fig. 1.

2. PWB configuration

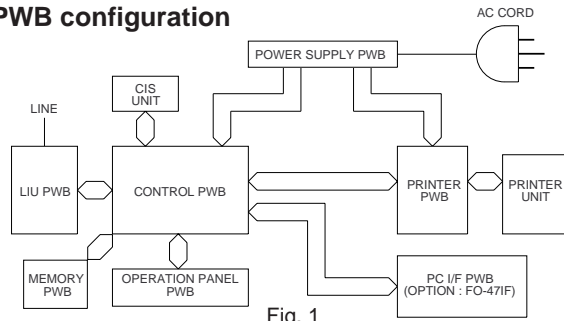

Fig. 1

1) Control PWB

The control PWB controls all the other operations except the printing operation of the printer.

2) LIU PWB

The LIU PWB controls the I/F telephone function of the circuit with the control signals from the control PWB.

3) CIS UNIT

CIS UNIT converts the image of the sending or copying draft into the photoelectric signals and transmits the signals to the control PWB.

4) Operation panel PWB

The operation panel PWB detects the key input, turns on and off LED and displays LCD according to the control signals from the control PWB.

5) Power supply PWB

DC voltages (+5V, +24V) are produced from AC120V, and are supplied to the printer unit and control PWB unit.

6) PC I/F PWB (Option : FO-47IF)

An interface to PC is done by IEEE1284, and image data (bitmap) from PC are outputted to the printer.

7) Memory PWB

The 2MByte image memory composed by flash memory which can be supported. When FO-3MK (OPTION) installed, a capacity rise is possible to 5 MByte.

[2] Circuit description of control PWB

1. General description

The control PWB is composed of the following blocks.

- ① Main control block
- ② Image memory block
- ③ Modem block
- ④ Image signal process block
- ⑤ Speaker amplifier
- ⑥ Reading process and mechanical control block
- ⑦ Gate array (A) block
- ⑧ Gate array (B) block
- ⑨ CODEC block
- ⑩ Page memory block
- ⑪ Drive block
- ⑫ JBIG block

2. Description of each block

(1) Main control block

The main control block uses RISC microprocessor HD6437021 as CPU, being composed of ROM (2 MByte), DRAM (2 MByte) and SRAM (256 KByte).

1) SH7021 (IC27): pin-100, QFP (main CPU)

The device is a microprocessor which integrates the peripheral functions, using CPU of 32-bit RISC type as the core. In the instrument, the following peripheral functions are mainly used.

- ① ROM of 32 KByte and RAM of 1 KByte are integrated.
A part of programs are stored in the integrated ROM.
- ② DMA controller (4 channels are provided, and 2 channels alone are used.)
ch.0: Used to transmit image data between CODEC (HD813201F) and DRAM (IC16).
ch.2: Used to transmit image data between Flash memory (option) and DRAM(IC16).
- ③ Clock-synchronous type serial communication interface commands and statuses are communicated with PCU.
- ④ Interruption
 $\overline{IRQ4}$, $\overline{IRQ7}$: Interruption request from gate array (A) (LZ9FJ59)
 $\overline{IRQ6}$: Interruption request from gate array (B) (LR38292)
 $\overline{IRQ0}$, $\overline{IRQ1}$, $\overline{IRQ2}$, $\overline{IRQ3}$, $\overline{IRQ5}$, $\overline{IRQ7}$: Not used.
 \overline{NMI} : Not used.
- ⑤ DRAM controller
Addressing to DRAM(IC16) of the system and control and refresh control of \overline{RAS} and \overline{CAS} signals are executed.
- ⑥ Timer and watch dog timer
- ⑦ General-purpose I/O port
Control of Liu and control of analog process of read signals are executed.
- ⑧ Clock oscillation
Crystal oscillator of 19.66 MHz is connected for operation of 19.66 MHz.
- ⑨ Generation of alarm sound and ringer sound
The keys on the operation panel are pressed to respectively generate the key input sound, alarm sound and ringer sound.

2) 27C160 (IC4): pin-42, DIP (EPROM)

Programs are stored in a 16 Mbit ROM.

3) HY5118164 or MSM5118165 (IC16): pin-42, SOJ (DRAM)

Used as the system memory of main CPU and transmission buffer of communication.

4) SM8578BV (IC30): pin-8, SOP (Real time clock IC)

It is oscillated with the quartz oscillator of 32.768 kHz, and the clock and calendar functions are provided. Even if the power supply of the main body is turned off, it is backed up with lithium battery. This device executes the clock-synchronous type serial communication with the gate array (A), and CPU can know the time and date through the gate array (A).

SH7021 (IC27) Terminal descriptions

Classification	Code	Terminal No. (TFP-100B)	I/O	Name	Function
Power	Vcc	13, 38, 63, 73, 80, 88	I	Power	Connect to the power supply. Connect Vcc terminals to the power units of all systems. If any open terminal is present, it will not operate
	Vss	4,15,24,32, 41,50,59,70, 81,82, 92	I	Ground	Connect to the ground. Connect Vcc terminals to the power units of all systems. If any open terminal is present, it will not operate.
Clock	EXTAL	71	I	External clock	Connect to the quartz oscillator. Moreover, EXTAL terminal can input the external clock. Use the same frequency for the quartz oscillator, external clock and system clock.
	XTAL	72	I	Crystal	Connect the quartz oscillator. Connect the same frequency of the system clock (CK). To input external clock from EXTAL terminal, open EXTAL terminal.
	CK	69	O	System clock	Supply system clock to the peripheral device.
System control	$\overline{\text{RES}}$	76	I	Reset	If this terminal is turned to the low level when NMI is at the high level, it will be brought into the power-on state. If this terminal is turned to the low level when NMI is at the low level, it will be brought into the manual.reset state.
	$\overline{\text{WDTOVF}}$	75	O	Watch dog timer overflow	It is overflow output signal from WDT.
	$\overline{\text{BREQ}}$	60	I	Bus right request	Select the low level to make the external device request the release of bus right.
	$\overline{\text{BACK}}$	58	O	Bus right request acknowledge	It indicates that the bus right is released to the external device. When receiving BACK signal, the device which outputs BREQ signal can know that bus right is obtained.
Operation mode control	MD2~MD0	79~77	I	Mode setting	The terminal determines the operation mode. During operation, don't vary any input value. The relationship between MD2 thru MD0 and operation modes are shown in the following list.
Interrupt	NMI	74	I	No-maskable interrupt	This is the interrupt request terminal which can not be masked. Either leading edge or trailing edge is selected for receiving.
	$\overline{\text{IRQ0}}\sim\overline{\text{IRQ7}}$	65,66,67,68, 97,98,99,100	I	Interrupt request 0 thru 7	This is the interrupt request terminal which can be masked. Either level input or edge input can be selected.
	$\overline{\text{IRQOUT}}$	61	O	Interrupt request output in the slave mode	It indicates that a factor of interrupt occurs. It indicates that interrupt occurs in the bus release mode.
Address	A21~A0	45~42,40,39, 37~33,31~25, 23~20	O	Address	Address is output.
Data bus	AD15~AD0	19~16,14, 12~5,3~1	I/O	Data bus	Bidirectional data bus of 16 bits Multiplex is possible with the low-order 16 bits of the address.
	DPH	64	I/O	High-order side data bus parity	Parity data corresponds to D15 thru D8.
	DPL	62	I/O	Low-order side data bus parity	Parity data corresponds to D7 thru D0.

(Continuing)

Relationship between MD2 thru MD0 and operation modes

MD2	MD1	MD0	Operation mode	Integrated ROM	Bus width of area 0
0	0	0	MCU mode	Invalid	8-bit size
0	0	1			16-bit size
0	1	0		Valid	—
0	1	1	(Reserved)	—	—
1	0	0	(Reserved)	—	—
1	0	1	(Reserved)	—	—
1	1	0	(Reserved)	—	—
1	1	1	(Reserved)	—	—

SH7021 (IC27) Terminal descriptions

Classification	Code	Terminal No. (TFP-100B)	I/O	Name	Function
Bus control	WAIT	54	I	Wait	It is input to insert Tw into the bus cycle during access to the external space.
	RAS	52	O	Low address strobe	Timing signal of low address strobe of DRAM
	CASH	47	O	High-order column address strobe	Timing signal of column address strobe of DRAM It is output for access to high-order 8 bits of data.
	CASL	49	O	Low-order column address strobe	Timing signal of column address strobe of DRAM It is output for access to low-order 8 bits of data.
	RD	57	O	Read	It indicates that outside is read out.
	WRH	56	O	High-order write	It indicates writing at the external high-order 8 bits.
	WRL	55	O	Low-order write	It indicates writing at the external low-order 8 bits.
	CS0-CS7	46-49, 51-54	O	Chip select 0 thru 7	Chip select signal for external memory or device
	AH	61	O	Address hold	Address hold timing signal for device which uses multiplex bus of address/data
	HBS, LBS	20 56	O	Low-/high-order byte strobe	Strobe signal of high/low byte (Commonly used with AO, WRH.)
WR	55	O	Write	Output during writing. (Commonly used with WRL.)	
DMAC	DREQ0, DREQ1	66,68	I	DMA transfer request (Channels 0 and 1)	Input terminal of DMA transfer request from external
	DACK0, DACK1	65,67	O	DMA transfer request receiving (Channels 0 and 1)	It indicates that DMA transfer request is received.
16-bit integrated timer pulse unit (ITU)	TIOCA0, TIOCB0	51, 53	I/O	ITU input capture/output conveyor (Channel 0)	Output terminal of input capture input/output conveyor
	TIOCA1, TIOCB1	62, 64	I/O	ITU input capture/output conveyor (Channel 1)	Output terminal of input capture input/output conveyor
	TIOCA2, TIOCB2	83, 84	I/O	ITU input capture/output conveyor (Channel 2)	Output terminal of input capture input/output conveyor
	TIOCA3, TIOCB3	85, 86	I/O	ITU input capture/output conveyor (Channel 3)	Output terminal of input capture input/output conveyor
	TIOCA4, TIOCB4	87, 89	I/O	ITU input capture/output conveyor (Channel 4)	Output terminal of input capture input/output conveyor
	TOCXA4, TOCXB4	90, 91	O	ITU output conveyor (Channel 4)	Output terminal of output conveyor
	TCLKA~ TCLKD	65,66,90, 91	I	ITU timer clock input	External clock input terminal to counter of ITU
Timing pattern controller (TPC)	TP15~ TP0	100~93, 91~89, 87~83	O	Timing pattern Output 15 thru 0	Output terminal of timing pattern
Serial communication interface (SCI)	TxD0, TxD1	94, 96	O	Sending data (Channels 0 and 1)	Sending data output terminal of SCI0, 1
	RxD0, RxD1	93, 95	I	Receiving data (Channels 0 and 1)	Receiving data input terminal of SCI0, 1
	SCK0, SCK1	97, 98	I/O	Serial clock (Channels 0 and 1)	Clock input/output terminal of SCI0, 1
I/O port	PA15~ PA0	68~64, 62~60, 58~51	I/O	Port A	Input/output terminal of 16 bits Input/output can be assigned for each bit.
	PB15~ PB0	100~93, 91~89, 87~83	I/O	Port B	Input/output terminal of 16 bits Input/output can be assigned for each bit.

(2) Image memory block

This block is composed of memory PWB circuit.
Refer to [2'] Circuit description of memory PWB for the details.

(3) Modem block

The block is mainly composed of the modem R288F (IC41), and is provided with the following modem function.

Table 1-1. Configurations, Signaling Rates, and Data Rates

Configuration	Modulation 1	Carrier Frequency (Hz) $\pm 0.01\%$	Data Rate (bps) $\pm 0.01\%$	Symbol Rate (Symbols/Sec.)	Bits/Symbol - Data	Bits/Symbol - TCM	Constellation Points
V. 34 33600 TCM	TCM	Note 2	33600	3429 only	Note 2	Note 2	Note 2
V. 34 31200 TCM	TCM	Note 2	31200	Note 2	Note 2	Note 2	Note 2
V. 34 28800 TCM	TCM	Note 2	28800	Note 2	Note 2	Note 2	Note 2
V. 34 26400 TCM	TCM	Note 2	26400	Note 2	Note 2	Note 2	Note 2
V. 34 24000 TCM	TCM	Note 2	24000	Note 2	Note 2	Note 2	Note 2
V. 34 21600 TCM	TCM	Note 2	21600	Note 2	Note 2	Note 2	Note 2
V. 34 19200 TCM	TCM	Note 2	19200	Note 2	Note 2	Note 2	Note 2
V. 34 16800 TCM	TCM	Note 2	16800	Note 2	Note 2	Note 2	Note 2
V. 34 14400 TCM	TCM	Note 2	14400	Note 2	Note 2	Note 2	Note 2
V. 34 12000 TCM	TCM	Note 2	12000	Note 2	Note 2	Note 2	Note 2
V. 34 9600 TCM	TCM	Note 2	9600	Note 2	Note 2	Note 2	Note 2
V. 34 7200 TCM	TCM	Note 2	7200	Note 2	Note 2	Note 2	Note 2
V. 34 4800 TCM	TCM	Note 2	4800	Note 2	Note 2	Note 2	Note 2
V. 34 2400 TCM	TCM	Note 2	2400	Note 2	Note 2	Note 2	Note 2
V. 23 1200/75	FSK	1700/420	1200/75	1200	1	0	—
V. 21	FSK	1080/1750	0-300	300	1	0	—
V. 17 14400 TCM	TCM	1800	14400	2400	6	1	128
V. 17 12000 TCM	TCM	1800	12000	2400	5	1	64
V. 17 9600 TCM	TCM	1800	9600	2400	4	1	32
V. 7200 TCM	TCM	1800	7200	2400	3	1	16
V. 29 9600	QAM	1700	9600	2400	4	0	16
V. 29 7200	QAM	1700	7200	2400	3	0	8
V. 29 4800	QAM	1700	4800	2400	2	0	4
V. 27 4800	DPSK	1800	4800	1600	3	0	8
V. 27 2400	DPSK	1800	2400	1200	2	0	4
V. 21 Channel 2	FSK	1750	300	300	1	0	—

Notes:

1. Modulation legend: TCM: Trellis-Coded Modulation QAM: Quadrature Amplitude Modulation
FSK: Frequency Shift Keying DPSK: Differential Phase Shift Keying

2. Adaptive; established during handshake:

Symbol Rate (Baud)	Carrier Frequency (Hz)	
	V. 34 Low Carrier	V.34 High Carrier
2400	1600	1800
2800	1680	1867
3000	1800	2000
3200	1829	1920
3429	1959	1959

Table 2-1. MDP Pin Signals -68- Pin PLCC

Pin	Signal Label	I/O Type	Interface 3	Pin	Signal Label	I/O Type	Interface
1	NC		NC	35	RXD	OA	DTE Serial Interface
2	NC	--	--	36	VDD2	PWR	
3	NC	--	--	37	-CTS	OA	DTE Serial Interface
4	NC	--	--	38	NC	--	--
5	-RI/TXRQ	OA	DTE Serial/DMA Interface	39	NC	--	--
6	RINGD	IA	LIU: RINGD	40	DGND3	GND	--
7	-RTS	IA	DTE serial Interface	41	VDD3	PWR	--
8	IRQ	OA	Host Parallel Interface	42	NC	--	--
9	D1	IA/OB	Host Parallel Interface	43	DGND4	GND	--
10	DGND1	GND		44	NC	--	--
11	VDD1	PWR		45	NC	--	--
12	XTLI	I	Crystal/Clock Circuit	46	EYESYNC	OA	Eye Pattern Test Circuit
13	XTLO	O	Crystal/Clock Circuit	47	-EYECLK	OA	Eye Pattern Test Circuit
14	D0	IA/OB	Host Parallel Interface	48	EYEXY	OA	Eye Pattern Test Circuit
15	D2	IA/OB	Host Parallel Interface	49	NC	--	--
16	D3	IA/OB	Host Parallel Interface	50	TDCLK	OA	DTE Serial Interface
17	D5	IA/OB	Host Parallel Interface	51	-RLSD	OA	DTE Serial Interface
18	D7	IA/OB	Host Parallel Interface	52	-RDCLK	OA	DTE Serial Interface
19	DGND2	GND		53	GP0	MI	MDP: EYESYNC
20	RS0	IA	Host Parallel Interface	54	XTCLK	IA	DTE Serial Interface
21	5VA	PWR		55	DGND5	GND	
22	AGND1	GND		56	VDD4	PWR	
23	RIN	I(DA)	Line Interface	57	TXD	IA	DTE Serial Interface
24	VC	MI	To GND through capacitors	58	-DSR/RXRQ	OA	DTE Serial/DMA Interface
25	VREF	MI	To VC through capacitors	59	-RESET	OA	Host Parallel Interface
26	TXA2	O (DD)	Line Interface	60	-READ	IA	Host Parallel Interface
27	TXA1	O (DD)	Line Interface	61	-WRITE	IA	Host Parallel Interface
28	-TALK (-RLYB)	OA	Line Interface	62	-CS	IA	Host Parallel Interface
29	SPKR	O (DF)	Speaker Circuit	63	RS4	IA	Host Parallel Interface
30	AGND2	GND		64	RS3	IA	Host Parallel Interface
31	-OHRC (-RLYA)	OD	Line Interface	65	RS2	IA	Host Parallel Interface
32	-POR	MI	MDP: -RESET	66	RS1	IA	Host Parallel Interface
33	NC	--	--	67	D6	IA/OB	Host Parallel Interface
34	-DTR	IA	DTE Serial Interface	68	D4	IA/OB	Host Parallel Interface

Notes:

1. I/O types:

MI= Modem interconnect.

IA, IB= Digital input

OA, OB = Digital output

I (DA) = Analog input

O (DD), O (DF) = Analog output

2. NC= No external connection allowed

3. Interface Legend:

MDP = Modem Data Pump

DTE = Data Terminal Equipment

The above functions are controlled by getting an access to the interface memory in the modem through the data bus from CPU (IC27) of the control PWB. The interface memory is composed of 32 8-bit registers, and is controlled with the bank switch. Accordingly, the register is selected by the register selection signals (RS4 to RS0) of 5 bits and chip selection signal (CS). The major content controlled by these registers is as follows.

1) Configuration register

Mode setting of V34, V17, V29, V27, G2, FSK and tone transmission.

2) Option register

Equalizing method of equalizer, carrier detection threshold, addition of echo suppressor protect tone, and setting of transmission/reception mode.

3) Others

G2AGC control, tone frequency setting, and so on.

Moreover, data is read from these registers through the data bus to monitor the statuses of the modem such as tone detection, training pattern detection and so on.

Next, transmission/reception operation is described.

During sending, the sent data is given from the control block to the modem through the data bus. Then, it is modulated and sent to LIU PWB with SIGTX signal. During receiving, the received data is sent from LIU PWB to the modem with SIGRX signal and is demodulated. Then, it is sent to the control block with the data bus. The above operation is done with the modem LSI (IC).

(4) Image signal process block

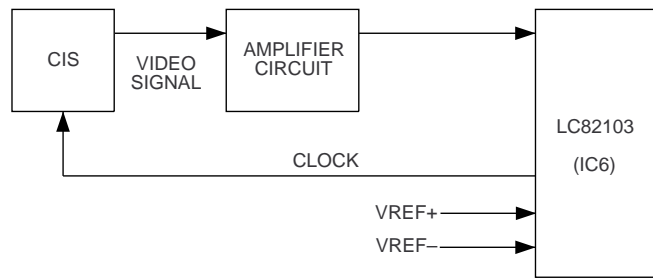

Fig. 2

The CIS is driven by the LSI (LC82103), and the output video signal from the CIS is input into the LC82103 through the amplifying circuit. The ADC and buffer are provided in the LC82103, and the digital image processing is performed.

(5) Speaker amplifier

The speaker amplifier monitors the line under the on-hook mode, outputs the buzzer sound generated from the SH7021, ringer sound, DTMF generated from the modem, and line sound.

(6) Reading process and mechanical control block

1) Mechanical control block

The mechanical control block is mainly composed of the gate array (A) (IC17: LZ9FJ59) to control the following.

(a) Sending motor control

The revolution speed and timing of the sending motor are controlled to output the control signals to the motor driver (IC7).

(b) End stamp and LED lamp control

On/off of the end stamp and LED lamp is controlled with the software.

(7) Gate array (A) block

This block is mainly composed of the gate array (A) (IC17: LZ9FJ59), and has the following functions.

- ① Mapper
Mapping is executed in the memory area of the memories, gate array (B), modem, CODEC and reading process LSI (LC82103).
- ② Mechanical control block
Refer to 1) Mechanical control block of 2-6 Reading and mechanical control block.
- ③ IC interface for clock
Writing and reading to IC (IC30: SM8578BV) for clock is executed in the clock-synchronous type serial transfer mode.
- ④ LIU control port
- ⑤ PC interface
 - Control of PC I/F Asic (FO-47IF)

LC82103 (IC6)

Type					
I	INPUT	B	BIDIRECTION	NC	NOT CONNECT
O	OUTPUT	P	POWER		

PIN	I/O	Name	Function	PIN	I/O	Name	Function
1	B	D7	CPU interface data bus pin D7 is the MSB pin, and D0 is the LSB pin.	43	P	AVDD	Analog system power supply pin.
2	B	D6		44	I	DALRH	D/A converter high reference voltage pin for A/D converter low reference voltage.
3	B	D5		45	O	ATAPL	D/A converter monitor signal output pin for A/D converter low reference voltage.
4	B	D4		46	P	AGND	Analog system ground pin.
5	B	D3		47	B	PD7/SD	DMA output pin/serial data output pin.
6	B	D2		48	B	PD6/SDCK	DMA output pin/serial data transmission clock pin.
7	B	D1		49	P	DGND	Digital system ground pin.
8	B	D0		50	B	PD5/SDE	DMA output pin/serial data
9	P	DGND	Digital system ground pin.	51	B	PD4/PP4	DMA output pin/general-purpose I/O port pin.
10	P	DVDD	Digital system power supply pin.	52	B	PD3/PP3	
11	I	A8	CPU interface address bus pin A12 is the MSB pin, and A0 is the LSB pin.	53	B	PD2/PP2	
12	I	A7		54	B	PD1/PP1	
13	I	A6		55	B	PD0/PP0	
14	I	A5		56	P	DVDD	Digital system power supply pin.
15	I	A4		57	B	DACK/PP5	DMA data acknowledge signal input pin/general-purpose I/O port pin.
16	I	A3	58	B	DREQ/PP6	DMA data request signal output pin/ general-purpose I/O port pin.	
17	P	DGND	Digital system ground pin.	59	B	MTP/PP7	Motor drive timing signal output pin/ general-purpose I/O port pin.
18	I	A2	CPU interface address bus pin.	60	O	CLK2	Sensor drive timing signal output pin.
19	I	A1		61	O	CLK1	
20	I	A0	21	I	WR	CPU interface write signal pin.	
21	I	WR	22	I	RD	CPU interface read signal pin.	
22	I	RD	23	I	A12	CPU interface address bus pin.	
23	I	A12	24	P	DVDD	Digital system power supply pin.	
24	P	DVDD	25	I	CLKIN	System clock input pin.	
25	I	CLKIN	26	I	A11	CPU interface address bus pin.	
26	I	A11	27	I	A10		
27	I	A10	28	I	A9		
28	I	A9	29	I	CS	CPU interface chip select signal pin.	
29	I	CS	30	I	ICLK	External sampling point signal input pin.	
30	I	ICLK	31	I	TRIG	External trigger signal input pin.	
31	I	TRIG	32	I	RESET	System reset pin.	
32	I	RESET	33	O	SAMP/LININT	A/D converter sampling point monitor signal output pin/LINE signal output pin.	
33	O	SAMP/LININT	34	I	TEST	Test pin (Connect to ground in normal use.)	
34	I	TEST	35	I	REF	DRAM refresh signal input pin.	
35	I	REF	36	P	AGND	Analog system ground pin.	
36	P	AGND	37	I	DALRL	D/A converter low reference voltage pin for A/D converter low reference voltage.	
37	I	DALRL	38	I	DAHRL	D/A converter low reference voltage pin for A/D converter high reference voltage.	
38	I	DAHRL	39	I	AIN	Sensor signal input pin.	
39	I	AIN	40	I	TEMP	Temperature signal input pin.	
40	I	TEMP	41	O	ATAPH	D/A converter monitor signal output pin for A/D converter high reference voltage.	
41	O	ATAPH	42	I	DAHRH	D/A converter high reference voltage pin for A/D converter high reference voltage.	
42	I	DAHRH					

Note : Not using the input pins must be connected to "Digital system power supply or ground".

LZ9FJ59 (IC17) Terminal list

PIN	I/O	Name	Function	PIN	I/O	Name	Function
1	IO2M	RTCDT	RTC data input/output	51	IO2M	D12	System data input/output
2	O2M	RTCCK	RTC data transfer clock	52	IO2M	D11	System data input/output
3	O2M	RTCCE	RTC chip select	53	IO2M	D10	System data input/output
4	O2M	RTCIO	RTC input/output control	54	I	A7	System address input
5	TO	GAIN	Output port	55	I	A6	System address input
6	I	MTSTART	Input port	56	I	A5	System address input
7	I	LCINT	Interrupt request signal from LC82103	57	I	A4	System address input
8	O2M	XLCCS	Chip select signal to LC82103	58	I	A3	System address input
9	O	AO9	Reading/QM-coder LSI address output	59	I	A2	System address input
10	O	AO10	Reading/QM-coder LSI address output	60	IS	SHCK	Clock (19.6MHz) from CPU
11	-	GND	Ground	61	-	GND	Ground
12	O	AO11	Reading/QM-coder LSI address output	62	-	VDD	Power supply
13	O	AO12	Reading/QM-coder LSI address output	63	I	A1	System address input
14	O2M	XLCRD	Read signal to LC82103	64	I	A0	System address input
15	O2M	XLCWR	Write signal to LC82103	65	IO2M	D9	System data input/output
16	O	AO0	Reading/QM-coder LSI address output	66	IO2M	D8	System data input/output
17	O	AO1	Reading/QM-coder LSI address output	67	IO2M	D7	System data input/output
18	O	AO2	Reading/QM-coder LSI address output	68	IO2M	D6	System data input/output
19	O	AO3	Reading/QM-coder LSI address output	69	IO2M	D5	System data input/output
20	-	VDD	Power supply	70	IO2M	D4	System data input/output
21	-	GND	Ground	71	IO2M	D3	System data input/output
22	O	AO4	Reading/QM-coder LSI address output	72	IO2M	D2	System data input/output
23	O	AO5	Reading/QM-coder LSI address output	73	IO2M	D1	System data input/output
24	O	AO6	Reading/QM-coder LSI address output	74	IO2M	D0	System data input/output
25	O	AO7	Reading/QM-coder LSI address output	75	-	GND	Ground
26	O	AO8	Reading/QM-coder LSI address output	76	IS	XRESET	Reset signal
27	O	CRNT	Output port	77	O2M	XINT7	Interrupt request signal to CPU
28	-	GND	Ground	78	O2M	XINT4	Interrupt request signal to CPU
29	O	TXB1	B-phase current control output 1	79	O2M	XWAIT	Wait request signal to CPU
30	O	TXB0	B-phase current control output 0	80	I	XRAS	Input RAS signal from CPU
31	O	TXA1	A-phase current control output 1	81	I	A18	System address input
32	O	TXA0	A-phase current control output 0	82	I	A19	System address input
33	O	TXPB	B-phase current direction setting	83	I	A20	System address input
34	O	TXPA	A-phase current direction setting	84	I	A21	System address input
35	I	A12	System address input	85	I	XCS2	Chip select 2 signal input
36	I	A11	System address input	86	I	XCS6	Chip select 6 signal input
37	I	A10	System address input	87	I	XWRL	System write (high-order byte) signal
38	I	A9	System address input	88	I	XWRH	System write (low-order byte) signal
39	I	A8	System address input	89	I	XRD	System read signal
40	-	GND	Ground	90	I	XDACK0	DMA acknowledge 0 input from CPU
41	ID	QMPDRQ	DMA request input (QM-coder)	91	O2M	XDREQ0	DMA request 0 output to CPU
42	O2M	XQMPDAK	DMA acknowledge output (QM-coder)	92	I	XDACK1	DMA acknowledge 1 input from CPU
43	ID	QMCDRQ	DMA request input (QM-coder)	93	O2M	XDREQ1	DMA request 1 output to CPU
44	O2M	XQMCDAK	DMA acknowledge output (QM-coder)	94	O2M	XGABCS	Chip select (gate array B)
45	O2M	XQMRD	Read signal to QM-coder	95	O2M	XSRAMCS	Chip select (SRAM)
46	O2M	XQMWR	Write signal to QM-coder	96	O2M	XPGMCS	Chip select (ROM)
47	O2M	XQMCS	Chip select signal to QM-coder	97	I	XMDMINT	Interrupt request signal from Modem
48	IO2M	D15	System data input/output	98	O2M	XMDMCS	Chip select (Modem)
49	IO2M	D14	System data input/output	99	O	XMDMRST	Modem reset output
50	IO2M	D13	System data input/output	100	-	VDD	Power supply

LZ9FJ59 (IC17) Terminal list

PIN	I/O	Name	Function	PIN	I/O	Name	Function
101	–	GND	Ground	131	O2M	XD6004RD	Read signal to D6004 (PC I/F)
102	O2M	XEXCS	Chip select (spare)	132	O2M	XD6004WR	Write signal to D6004 (PC I/F)
103	I	XCDCINT	Interrupt request signal from CODEC	133	O2M	D6004ALE	Address strobe signal to D6004 (PC I/F)
104	I	XCDCRQ	DMA request signal (CODEC)	134	–	GND	Ground
105	O2M	XCDCCS	Chip select (CODEC)	135	IO	AD7	PC I/F address/data input/output
106	O	XWR	System write output	136	IO	AD6	PC I/F address/data input/output
107	O2M	FLBK4	Bank control 4	137	IO	AD5	PC I/F address/data input/output
108	O2M	FLBK3	Bank control 3	138	IO	AD4	PC I/F address/data input/output
109	O2M	FLBK2	Bank control 2	139	IO	AD3	PC I/F address/data input/output
110	O2M	FLBK1	Bank control 1	140	IO	AD2	PC I/F address/data input/output
111	IU	XFLBSY	Flash memory busy signal input	141	–	GND	Ground
112	IU	FLSZ0	Input port	142	–	VDD	Power supply
113	IU	FLSZ1	Input port	143	IS	CK16M	16MHz clock input
114	O2M	XFLSTD	Chip select (flash standard)	144	ID	TEST1	Test terminal
115	O2M	XFLOPT	Chip select (flash option)	145	IO	AD1	PC I/F address/data input/output
116	IU	XCI	Input port	146	IO	AD0	PC I/F address/data input/output
117	IU	XRHS	Input port	147	IU	XB4FRS	Input port
118	IU	XEXHS	Input port	148	IU	XFRSNS	Input port
119	TO	DPON	Output port	149	IU	XORGSNS	Input port
120	–	GND	Ground	150	IU	XROLSNS	Input port
121	TO	TXMUTE	Output port	151	I	PRTSNS1	Input port
122	IU	HSDTCT	Input port	152	TO	CDCMSK	Output port
123	TO	MPXC	Output port	153	TO	PLG0ON	Plunger 0 control
124	TO	MPXB	Output port	154	TO	PLG1ON	Plunger 1 control
125	TO	DPMUTE	Output port	155	TO	LEDON	CIS LED light source control
126	IU	PCDTCT	Input port	156	IU	XEXINT0	Interrupt request signal from PC I/F
127	TO	FAXPCSL	Output port	157	IU	XEXINT1	Interrupt request signal (spare)
128	O2M	XD9001CS	Chip select (PC I/F D9001)	158	I	PCIFSL	PC I/F select signal input
129	O2M	XD9001RW	Read signal to D9001 (PC I/F)	159	IO2M	IOP0	Input port (spare)
130	O2M	XD9001WR	Write signal to D9001 (PC I/F)	160	–	GND	Ground

I : Input terminal (TTL level input)

IS : Input terminal (TTL level schmitt input)

IU : Input terminal (TTL level input, pull up resistor 250 K Ω building in)

ID : Input terminal (TTL level input, pull down resistor 250 K Ω building in)

IO : Input/output terminal (TTL level input, output electric current: I_{OL}=4.0 mA)

IO2M : Input/output terminal (TTL level input, output electric current : I_{OL}=2.0 mA)

O : Output terminal (Output electric current: I_{OL}=4.0 mA)

O2M : Output terminal (Output electric current: I_{OL}=2.0 mA)

TO : Try-state output terminal (Output electric current: I_{OL}=4.0 mA)

VDD : Power supply

GND : Ground

(8) Gate array (B) block

The block is composed of the gate array (B) and SRAM (2 KByte).

1) LR38292(IC10) ... pin-160, QFP (gate array B)

The device has the following functions.

- ① Printing data process
The image data of the page memory for printing is converted into 400 dpi, and the smoothing and contracting processes are applied.
- ② Printer (PCU) interface
The control of resetting and so on to PCU and the image data processed in Item ① above are synchronized with the signal (HSYNC) from PCU and are transmitted to PCU in the serial mode.
- ③ DMA controller
 - (a) The binary-coded data of the draft transmitted in the serial mode from the gate array (A) LZ9FJ59(IC17) and read with the scanner are transmitted to the page memory.
 - (b) The image data which will be printed are read from the page memory, and the process ① is applied to transmit the data to PCU in the serial mode.
- ④ CODEC (HD813201F) interface
 - (a) The timing is controlled for CPU to get an access to CODEC.
 - (b) The timing is controlled for CODEC to get an access to the page memory.
- ⑤ DRAM controller
Since DRAM is used for the page memory, and the address, RAS and CAS are controlled and refresh-controlled.
- ⑥ Panel interface
The key input detection on the operation panel, LED lighting control and LCD display control are executed.

2) LH5116NA-10 (IC3) -- pin-24, SOP (16-Kbit SRAM)

This SRAM is a line memory for the printing data process (resolution power conversion, smoothing and contracting to 404 dpi) of the gate array (B).

LR38292 (IC10) Terminal descriptions

Pin	Name	I/O	Function	
20	VCC		Power supply	
62	VCC			
100	VCC			
142	VCC			
16	GND			Ground
21	GND			
35	GND			
48	GND			
61	GND			
78	GND			
87	GND			
101	GND			
125	GND			
134	GND			
143	GND			
65	MANRESB	O	Manual reset signal	
66	RESETB	I	Reset signal	
89	A5	I	Address signal on the system side	
90	A4			
91	A3			
92	A2			
93	A1			
70	D15	I/O	Data bus signal on the system side	
71	D14			
72	D13			
73	D12			
74	D11			
75	D10			
76	D9			
77	D8			
79	D7			
80	D6			
81	D5			
82	D4			
83	D3			
84	D2			
85	D1			
86	D0			
88	CSB	I	Chip select signal of gate array LR38292	
97	RDB	I	Read signal on the system bus side	
98	WRB	I	Write signal on the system bus side	
115	SHCK0B	O	Reversion output of clock (SHCK) from CPU	
116	SHCK	I	Clock (19.6 MHz) from CPU	
95	GAINTB	O	Interrupt request signal to CPU of gate array LR38292	
94	CDCINTB	O	Reversion output (to CPU) of interrupt request signal from HD813201F	
96	DREQ0B	O	Reversion output (to CPU) of DMA transfer request signal from HD813201F	
99	RSTDCB	O	Reset signal to HD813201F (Default: Low)	
102	CDCINT	I	Interrupt request signal from HD813201F	
103	BRQT	I	Bus right request signal of image bus from HD813201F	
104	BACKB	O	Bus right permission signal of image bus to HD813201F	
105	DRQ0	I	DMA transfer request signal from HD813201F	
106	DACK0B	O	Acknowledge signal of DMA transfer to HD813201F	
107	CSCDCB	I	Chip select signal to HD813201F	
108	MDENB	I	Data enable signal of image bus from HD813201F	
109	READY	O	Ready signal of image bus access to HD813201F	
110	MAS	I	Address strobe signal of image bus of HD813201F	

LR38292 (IC10) Terminal descriptions

Pin	Name	I/O	Function
111	MAENB	I	Address enable signal of image bus of HD813201F
112	CK16M	I	16 MHz clock input
113	RDCDC	O	Register read signal (active H) of HD813201F of CPU
114	RDCDCB	O	Register read signal (active L) of HD813201F of CPU
139	MA20	I	Address of image bus of HD813201F
138	MA19		
137	MA18		
136	MA17		
135	MA16		
133	MAD15		
132	MAD14		
131	MAD13		
130	MAD12		
129	MAD11		
128	MAD10		
127	MAD9		
126	MAD8		
124	MAD7		
123	MAD6		
122	MAD5		
121	MAD4		
120	MAD3		
119	MAD2		
118	MAD1		
117	MAD0		
155	DA11	I/O	Address bus to memory of image bus (page memory) When HD813201F gets an access to the image bus, address of MA21 thru MA16, MAD15 thru MAD1 are converted to Row/Column address in the page memory (DRAM) and output. When gate array LR38292 gets an access to the image bus, Row/Column address is output to the page memory (DRAM).
154	DA10		
153	DA9		
152	DA8		
151	DA7		
150	DA6		
149	DA5		
148	DA4		
147	DA3		
146	DA2		
145	DA1		
144	DA0		
156	DWEB	O	Write signal to memory (page memory: DRAM) of image bus
157	RAS1B	O	RAS1 signal to memory (page memory: DRAM) of image bus
158	RAS0B	O	RAS0 signal to memory (page memory: DRAM) of image bus
159	CASB	O	CAS signal to memory (page memory: DRAM) of image bus
140	DRMSIZE	I	Setting of size of memory (page memory: DRAM) of image bus Low: 16 Mbits High: 12 Mbits
141	DRMTYPE	I	Setting of type of memory (page memory: DRAM) of image bus Low: Address 8-bit type High: address 12-bit type (Valid only for DRMSIZE=L. Don't care for DRMSIZE=H.)
67	STVDB	I	Serial scanner data valid range signal
68	SRVID	I	Serial scanner data
69	SCCLK	I	Serial scanner data transfer clock
51	PCURESB	O	Reset signal for printer unit
52	HSYNC	I	Main scanning synchronous signal from printer unit
53	EPRDYB	I	Communication ready signal from printer unit
54	PRRDYB	I	Printing operation ready signal of printer unit
55	TODB	I	Sub-scanning synchronous signal to printer unit

Pin	Name	I/O	Function
56	ETBSYB	I	Status sending signal of printer unit
57	CTBSYB	O	Command sending signal to printer unit
58	PRINTB	O	Printing start/continuation signal to printer unit
59	PDATA	O	Printing image data to printer unit
60	CPRDYB	O	Communication ready signal to printer unit
63	XIN	I	Clock input (quartz oscillator connection)
64	XOUT	O	Clock output (quartz oscillator connection)
38	LMA10	O	Address bus of line memory for smoothing/contracting
37	LMA9		
36	LMA8		
34	LMA7		
33	LMA6		
32	LMA5		
31	LMA4		
30	LMA3		
29	LMA2		
28	LMA1		
27	LMA0		
40	LMD7	O	Data bus of line memory for smoothing/contracting
41	LMD6		
42	LMD5		
43	LMD4		
44	LMD3		
45	LMD2		
46	LMD1		
47	LMD0		
39	LMWEB	I/O	Control/data bus and LED on/off control signal to key scan and LCD driver on the operation panel
26	LD15		
25	LD14		
24	LD13		
23	LD12		
22	LD11		
19	LD10		
18	LD9		
17	LD8		
15	LD7		
14	LD6		
13	LD5		
12	LD4		
11	LD3		
10	LD2		
9	LD1		
8	LD0		
160	SEN7	I	Key input detection signal of operation panel
1	SEN6		
2	SEN5		
3	SEN4		
4	SEN3		
5	SEN2		
6	SEN1		
7	SEN0		
49	MEMTST	I	Terminal for device test of integrated memory Low is set except in the device test mode.
50	TEST	I	Terminal for device test Low is set except in the device test mode.

(9) CODEC block

This block is composed of CODEC, LS374 and LS244 in order to demodulate the contracted image data of the draft read with the scanner and the letter image transmitted in the DMA mode from the system memory.

1) HD813201F (IC12) ... pin-80, 6FP (CODEC)

It operates at 16 MHz corresponding to the crystal oscillator (X2) of 16 MHz.

The image memory is commonly used as the page memory. The image data of the draft read with the scanner in the page memory is contracted by MMR, and is transferred to the system memory (DRAM: IC16) by the DMA transfer function of CPU. Moreover, the image data transferred in the DMA mode from the system memory are demodulated with MMR, and are developed into the page memory.

2) HD74LS374 (IC18) ... pin-20, SOP

The data hold time during writing from main CPU to HD813201F is assured.

3) HD74LS244 (IC20) ... pin-20, SOP

When the main CPU reads the inner register of HD813201F, it will read the data through this buffer.

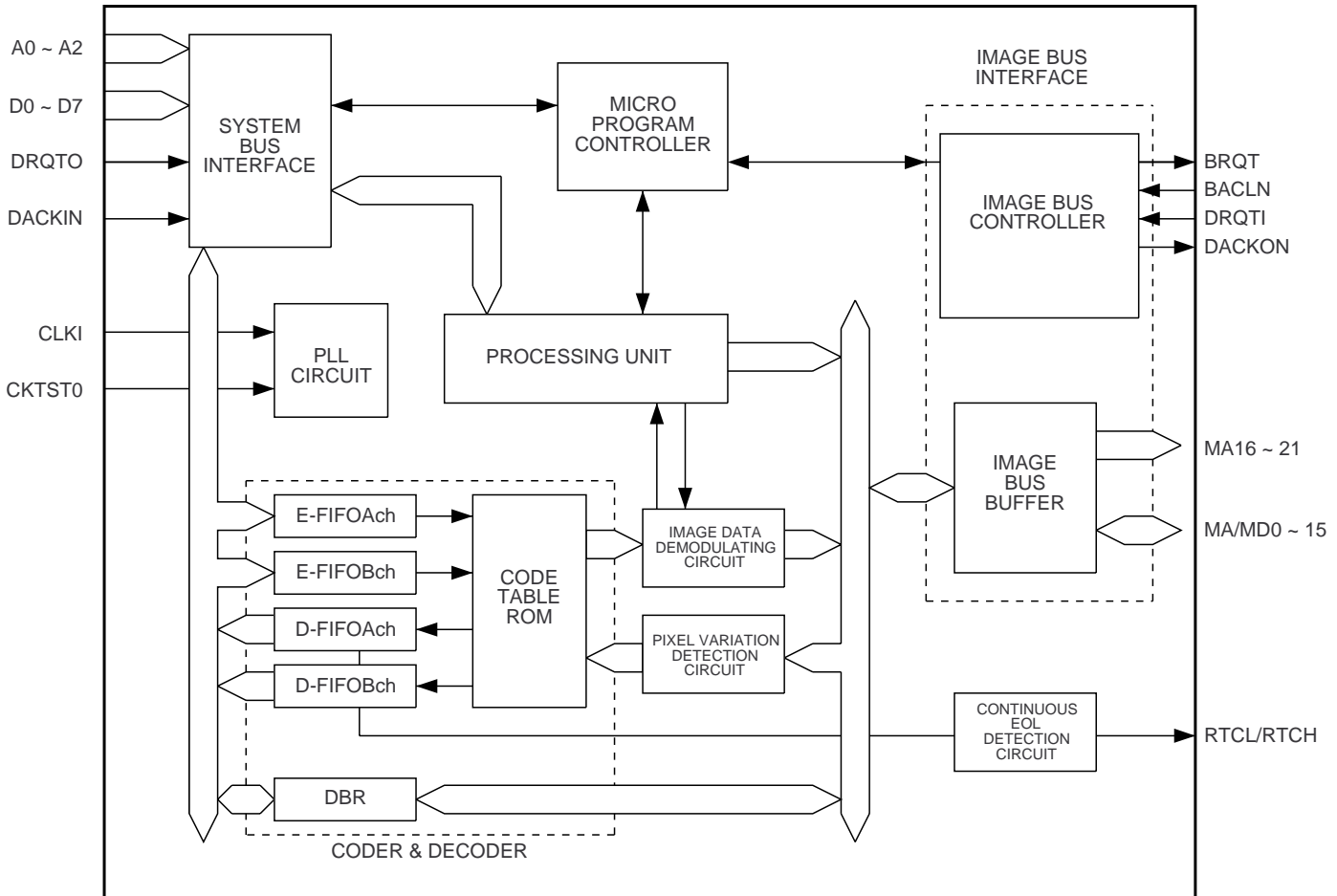

Fig. 3

HD813201F (IC12) Terminal descriptions

Code	Terminal No.	I/O	Function
$\overline{68}/80$	56	I	If this terminal is at "low" level, it indicates that MPU of system 88 is connected to IDP201. "High" level indicates that MPU of system 80 is connected.
A0	57	I	Addresses 0 thru 2 (address terminals). It is connected to the low-order 3 bits of the system address bus, and MPU is used to get an access to the internal register of IDP201.
A1	54		
A2	55		
D0	64	I/O, Three-state output	Data 0 thru 7 (data terminals). They are connected to the system data bus for bidirectional data transfer between MPU and IDP201. MPU can read and write the internal register of IDP201.
D1	62		
D2	65		
D3	63		
D4	67		
D5	66		
D6	68		
D7	69		
\overline{CS}	44	I	Chip select (chip select terminal). When the terminal is at "low" level, it indicates that MPU gets an access to the internal register of IDP201.
DS	45	I	Data strobe (data strobe terminal). Connect $\phi 2$ clock pin of MPU of system 88 or \overline{RD} pin of MPU of system 80.
R/\overline{W}	42	I	Read/write (read/write terminal). Connect R/\overline{W} pin of MPU of system 88 or \overline{WR} pin of MPU of system 80.
\overline{RESET}	59	I	Reset element. If the signal of "low" level is input to the terminal, IDP201 will be initialized.
IRQT	58	O	Interrupt request (interrupt request terminal). When the signal of "high" level is output, IDP201 requests the interrupt process for MPU. The factor of the interrupt is the end of the command process, the end of DMA transfer, occurrence of an error during demodulation or the receiving of RTC code. MPU reads IRR (interrupt request register) which is one of the internal registers of IDP201, and can know the factor of the interrupt. When MPU reads IRR, IRQT becomes "low" level. (For details of IRR, refer to "8.1.2 Interrupt request register".)
DRQTO	47	O	DMA Request Output (DMA request output terminal). In the following cases, DMA transfer can be requested for DMAC by turning DRQTO to "high". (1) During coding, a code of 1 byte or more is stored in E-FIFO. (2) During decoding, an empty area of 1 byte or more is present. (3) During data transfer between the system bus and image bus, DBR is read to read or write.
\overline{DACKI}	46	I	DMA Acknowledge Input (DMA acknowledge input terminal) The response signal for DRQTO is input. If \overline{DACKI} becomes "low" level during coding or decoding, the access is given to E-FIFO or D-FIFO. If \overline{DACKI} becomes "low" level during data transfer between system bus and image bus, the access is given to DBR. Don't make \overline{CS} and \overline{DACKI} "low" at the same time.
BRQT	52	O	Bus Request (Bus request terminal). IDP201 outputs the signal of "high" level from BRQT, and IDP201 requests the bus master for the device which can become another bus master on the image bus. If any other device which can become the bus master on the image bus, BRQT becomes the NC pin.
\overline{BACK}	48	I	Bus Acknowledge (bus acknowledge terminal). The response signal for BRQT is input. If the signal of "low" level is input to \overline{BACK} , it indicates that it is approved for IDP201 to become the bus master of the image bus. If any other bus master which can become the bus master is not present except IDP201, fix this terminal at "low".
\overline{MAEN}	76	O	Memory Address Enable (Memory address enable terminal). IDP201 outputs the signal of "low" level from \overline{MAEN} to declare that it becomes the bus master of the image bus. When \overline{MAEN} is at "high", the three-state output which is connected to the image bus becomes all into the high impedance state.

HD813201F (IC12) Terminal descriptions

Code	Terminal No.	I/O	Function
MAS	74	O	Memory Address Strobe (Memory address strobe terminal). When MAS becomes "high" level, it indicates that address is output to MA/MD0 thru MA/MD15 and MA16 thru MA21.
UDS	27	Three-state output	Upper Data Strobe (high-order data strobe terminal). When \overline{UDS} becomes "low" level, it indicates that IDP201 uses the high-order byte of the image bus.
\overline{LDS}	23	Three-state output	Upper Data Strobe (low-order data strobe terminal). When \overline{LDS} becomes "low" level, it indicates that IDP201 uses the low-order byte of the image bus.
\overline{MDEN}	25	O	Memory Data Bus Enable (Memory data bus enable terminal). When \overline{MDEN} output terminal becomes "low" level, it indicates that valid data are present in MA/MD0 thru MA/MD15. This output terminal is used to control the output of the bidirectional bus buffer on MA/MD0 thru MA/MD15.
MA/MD 0	79	I/O, Three-state output	Memory Address Data Bus 0 thru 15 (Memory address data bus). In this bus for image bus operation, the address and data are multiplexed. MA/MD0 thru MA/MD15 are used as follows. (1) When \overline{MAEN} is "low" and MAS is "high", it is used as the output address line. (2) When both \overline{MAEN} and \overline{MDEN} are "low" in the reading cycle, it is used as the input data line. (3) When both \overline{MAEN} and \overline{MDEN} are "low" in the writing cycle, it is used as the input data line.
MA/MD 1	77		
MA/MD 2	3		
MA/MD 3	78		
MA/MD 4	5		
MA/MD 5	2		
MA/MD 6	6		
MA/MD 7	4		
MA/MD 8	8		
MA/MD 9	7		
MA/MD10	12		
MA/MD11	9		
MA/MD12	14		
MA/MD13	13		
MA/MD14	15		
MA/MD15	16		
MA16	71	Three-state output	Memory Address Bus 16 thru 21 (memory address bus). When \overline{MAEN} is "low" and MAS is "high", it is used as the output address line.
MA17	11		
MA18	30		
MA19	31		
MA20	50		
MA21	51		
\overline{MR}	26	Three-state output	Memory Read (Memory read terminal). When \overline{MR} is turned to "low" level, IDP201 reads the data from the image memory.
\overline{MW}	28	Three-state output	Memory Write (memory write terminal). When \overline{MW} is turned to "low" level, IDP201 writes the data in the image memory.
\overline{IOR}	35	Three-state output	I/O Read (I/O read terminal). When \overline{IOR} is turned to "low" level, IDP201 reads the data from I/O device on the image bus. However, it is limited at DMA transfer during data transfer with the transfer command and the coding process.
\overline{IOW}	36	Three-state output	I/O Write (I/O write terminal). When \overline{IOW} is turned to "low" level, IDP201 writes the data in I/O device on the image bus. However, it is limited at DMA transfer during data transfer with the transfer command and the decoding process.
DRQTI	39	I	DMA Request Input (DMA request input terminal). When I/O device on the image bus requests DMA for IDP201, DRQTI becomes "high" level.
\overline{DACKO}	38	O	DMA Acknowledge Output (DMA acknowledge output terminal). When this output terminal is turned to "low" level, IDP201 informs to the peripheral devices on the image bus that DMA operation is approved.
\overline{DMA}	32	O	Direct Memory Access (Direct memory access terminal). When \overline{DMA} output is turned to "low", it indicates that DMA transfer is executed. In the coding process, the data is transferred from the I/O device (scanner) to the image memory. In the decoding process, the data is transferred from the image memory to I/O device (printer).

HD813201F (IC12) Terminal descriptions

Code	Terminal No.	I/O	Function
DTC	37	O	DMA Terminal Count (DMA terminal count terminal). When DTC output is turned to "high", it indicates that DMA transfer of the setting line part is ended.
READY	73	I	Image memory or I/O device read. When READY is turned to "high" during writing, it indicates that the image memory or I/O device is ready for transmitting/receiving the data. When READY is "high", IDP201 will wait until READY becomes "high".
<Power terminal>			
V _{DD} 1	29	I	Power voltage (+5V)
V _{DD} 2	49	I	
V _{DD} 3	72	I	
V _{SS} 1	10	I	
V _{SS} 2	17	I	Ground
V _{SS} 3	34	I	
V _{SS} 4	53	I	
V _{SS} 5	70	I	
V _{SS} 6	75	I	
<Other>			
TEST 0	18	I	Fix these terminals at "low".
TEST 1	22	I	
TEST 2	24	I	
TEST 3	33	I	
TEST 4	43	I	

Code	Terminal No.	I/O	Name and function
CLKI	19	I	Quartz oscillation input terminal and external clock input terminal.
CLKX	20	O	Quartz oscillation output terminal.
CKTST1	1	I	Low pass filter terminal of PLL circuit. Connected to capacitor (1000pF) and resistor (10kΩ) through GND.
CLKMOD	40	I	Terminal to switch quartz oscillation connection or external clock input mode. "0": Quartz oscillation. "1": External clock.
CKTST0	41	I	Fix at "LOW" level.
CLKO	21	O	Clock output terminal. Rectangular wave which is synchronous with the internal clock of IDP201 is output.
CKTST2	80	I	Fix at "LOW" level.

Code	Terminal No.	I/O	Name and function
RTCH	60	O	Number of transfers of EOL detected by IDP201 during RTC receiving is reflected at the terminal.
RTCL	61	O	

(10) Page memory block

The page memory block is composed of one DRAM of 1M × 16 bits, being commonly used as the image memory. The memory is divided into the page memory for the scanner and the page memory for printing.

The page memory for scanner is composed of the partial area of IC9. The image data of approx. one page (except in the super fine mode) of the draft read with the scanner can be stored. They are stored until they are contracted by CODEC.

The page memory for printing is composed of the remaining areas of IC9 and can store approx. one page of the image data decoded by CODEC. The data are stored until they are transferred to PCU with the gate array (B) and printed.

(11) Driver block

Sending motor driver (IC7: LB1845) ---- 28-pin DIP

This IC driver at the sending motor at the constant current with the bipolar, chopper system.

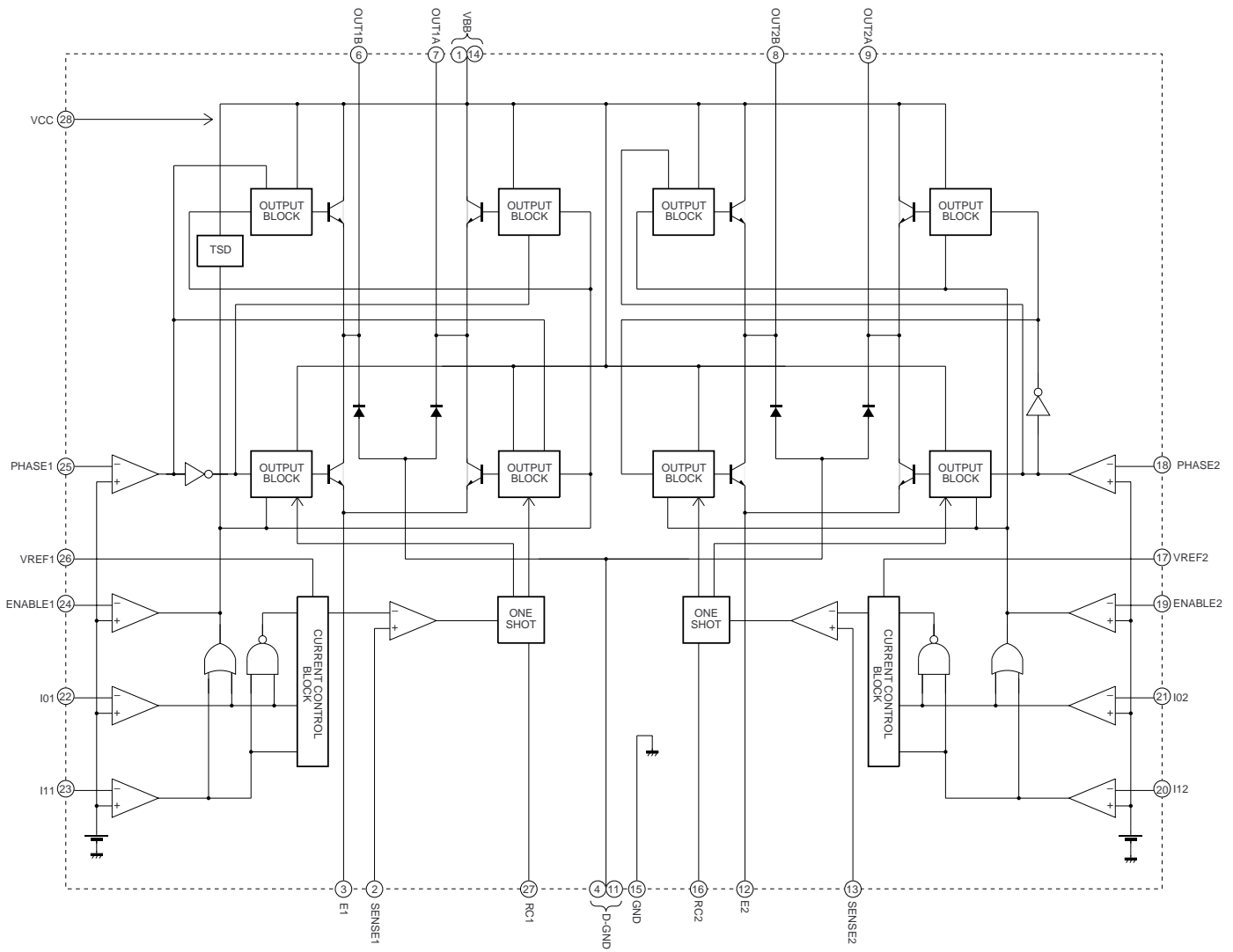

Fig. 4

[Truth Table]

ENABLE	PHASE	OUTA	OUTB
L	H	H	L
L	L	L	H
H	-	OFF	OFF

I_0	I_1	Output Current
L	L	$V_{ref} / (10 \times R_E) = I_{OUT}$
H	L	$V_{ref} / (15 \times R_E) = I_{OUT} \times 2/3$
L	H	$V_{ref} / (30 \times R_E) = I_{OUT} \times 1/3$
H	H	0

Note: When ENABLE = H or $I_0 = I_1 = H$, the output is in OFF state.

[Pin Functions]

Pin name	Pin No.	Pin Description
VBB	1, 14	Output stage power-supply voltage
SENSE1	2	Set current detection pins.
SENSE2	13	Connect these pins, fed back through noise filters, to E1, and E2.
E1	3	Current control pins by connecting between this pin and GND.
E2	12	
DGND	4,11	Internal diode anode connection
OUT1B	6	Output pins
OUT1A	7	
OUT2B	8	
OUT2A	9	
GND	15	Ground
RC1	27	Used to set the output off time for the switched output signals.
RC2	16	The fixed off times are set by the capacitors and resistors connected to these pins. $t_{off} \approx CR$
Vref1	26	Output current settings
Vref2	17	The output current is determined by the voltage (in the range 1.5 to 7.5V) input to these pins.
PHASE1	25	Output phase switching inputs. [H] input : OUT A = high, OUT B = low [L] input : OUT A = low, OUT B = high
PHASE2	18	
ENABLE1	24	Output on/off settings [H] input : output OFF [L] input : output ON
ENABLE2	19	
I01, I11	22, 23	Digital inputs that set the output current
I02, I12	21, 20	The output currents can be set to 1/3, 2/3, or full by setting these pins to appropriate combinations of high and low levels.
VCC	28	Logic block power supply.

(12) JBIG block

When it sends FAX by the JBIG compression form, the JBIG compression of the image data and JBIG expansion are done with QM-CODER LSI of IC23 (M65761).

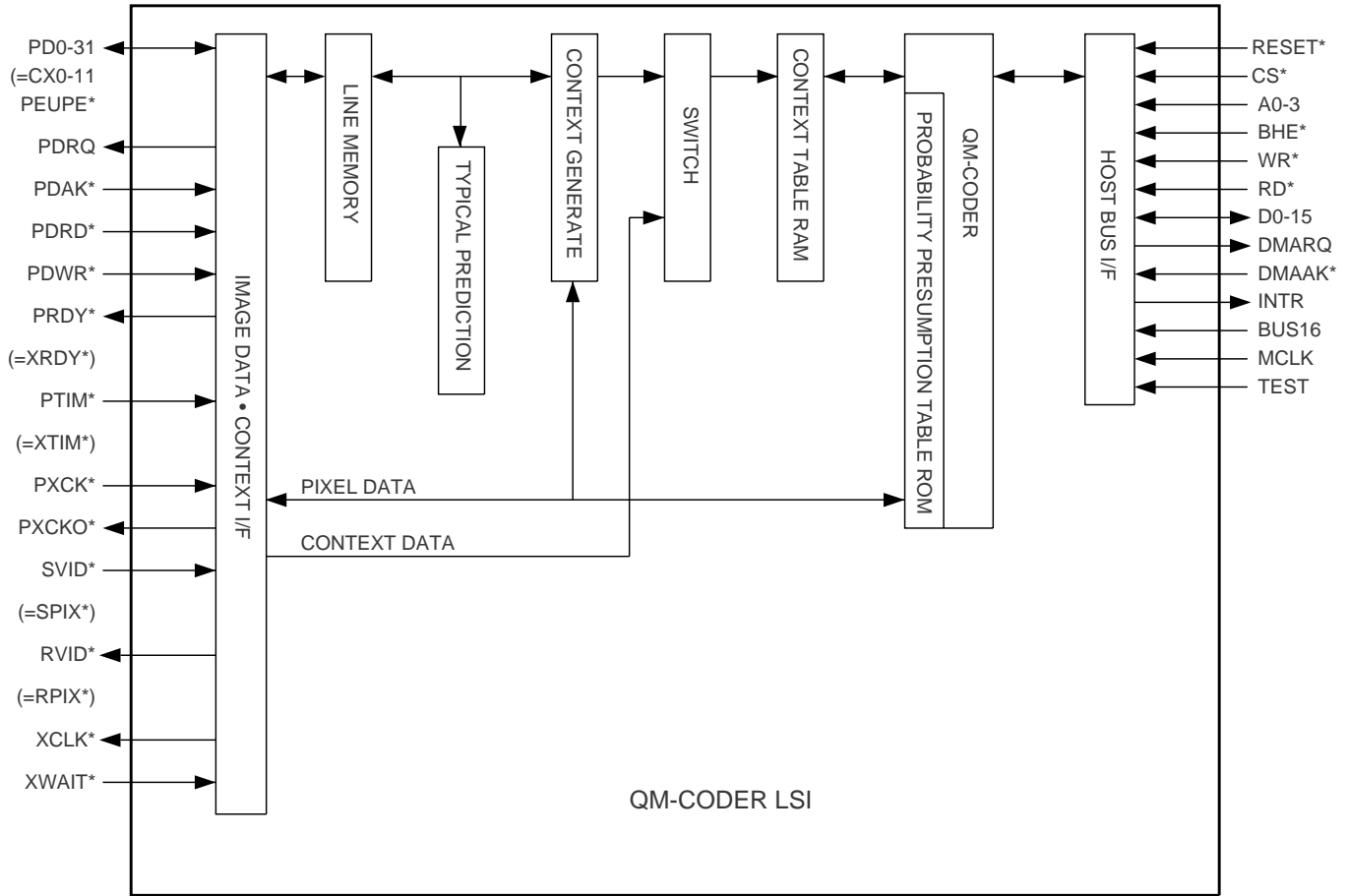

IC23: VHiM65761FP-1(M65761FP)

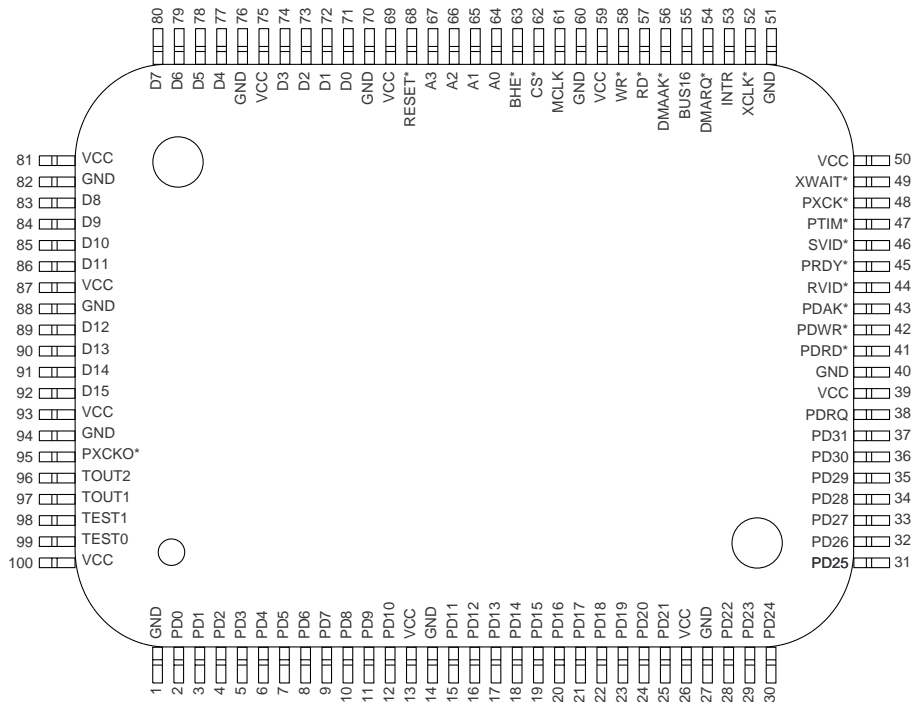

M65761FP (IC23) Terminal descriptions

I/F	Signal name	Terminal No	I/O	Function
Host bus I/F (29 pin)	RESET*	68	I	H/W reset signal.
	CS*	62	I	Chip select signal.
	A0-3	64,65,66,67	I	Address select signal of inner register.
	BHE*	63	I	Access signal of upward byte (D8-15).
	WR*	58	I	Write strobe signal.
	RD*	57	I	Read strobe signal.
	D0-15	71~74, 77~80, 83~86, 89~92	IO	Input/output data signal. (Use D0-7 when 8 bit bus)
	DMARQ	54	O	DMA request signal of encode data.
	DMAAK*	56	I	DMA acknowledge signal of encode data.
	INTR	53	O	Interrupt request signal.
BUS16	55	I	8 bit bus (D0-7) and 16 bit bus (D0-15) function select line.	
Image data I/F Parallel	PD0-31	2~12 15~25 28~37	IO	Parallel image input/output bus. (Use PD0-15 when 16 bit bus)
	PDRQ	38	O	DMA request signal of image data.
	PDAK*	43	I	DMA acknowledge signal of image data.
	PDRD*	41	I	Read strobe signal of image data.
	PDWR*	42	I	Write strobe signal of image data.
Image data I/F Serial	PRDY*	45	O	1 line input/output start ready signal of image data.
	PTIM*	47	I	1 line transfer section signal of image data.
	PXCK*	48	I	Transfer clock signal of image data.
	PXCKO*	95	O	Transfer synchronization clock signal of image data.
	SVID*	46	I	Input signal of image data.
	RVID*	44	O	Output signal of image data.
Context I/F	CX0-11	2~12,15	I	Context input. (CX0 is possible to feed back in LSI) (=PD0-11)
	PEUPE*	19	I	Updata enable of RAM for PE. (Learning function ON/OFF) (=PD15)
	SPIX*	46	I	Encode image data input signal. (=SVID*)
	RPIX*	44	O	Decode image data output signal. (=RVID*)
	XCLK*	52	O	Context data transfer clock signal.
	XWAIT*	49	I	Context data transfer wait signal.
	XRDY*	45	O	Context data 1 stripe input/output start ready signal. (=PRDY*)
	XTIM*	47	I	Context data 1 stripe transfer section signal. (=PTIM*)
Others	MCLK	61	I	Master clock input signal.
	TEST0-1	98,99	I	Signal for test. (Usually connect to GND)
	VCC/GND	1,13,14,26,27, 39,40,50,51,59, 60,69,70,75,76, 81,82,87,88,93, 94,100	-	Power(+5V)/Ground.

Note : Most of context IF signal line is shared with image data I/F signal line.
It is shown that * of the signal name is negative logic.

[2-1] Circuit description of memory PWB

It is composed by the flash memory of 2Mbyte, and attached to the CNOP connector of the control PWB circuit. It can be expanded by substituting FO-3MK(OPTION) for the standard memory PWB to 5MB.

**1) LH28F016SUT(IC4) ... pin-56, TSOP
(16 Mbit flash memory)**

This memory is a nonvolatile type whose content does not volatilize even if power is turned off, and stores the copied, sent and received image data. Moreover, the initially registered data, registered content of "RELAY" key and registered content of "CONF" key are stored.

**2) W24010S-70L(IC21, IC36) ... pin-32, SOP
(1 Mbit SRAM)**

The setting of receiving mode, optional setting content, soft switch content and daily data are stored. Even if the power supply of the main body is turned off, it is backed up with a lithium battery.

CHAPTER 6. CIRCUIT SCHEMATICS AND PARTS LAYOUT

[1] Control PWB circuit CPU & DRAM & ROM block

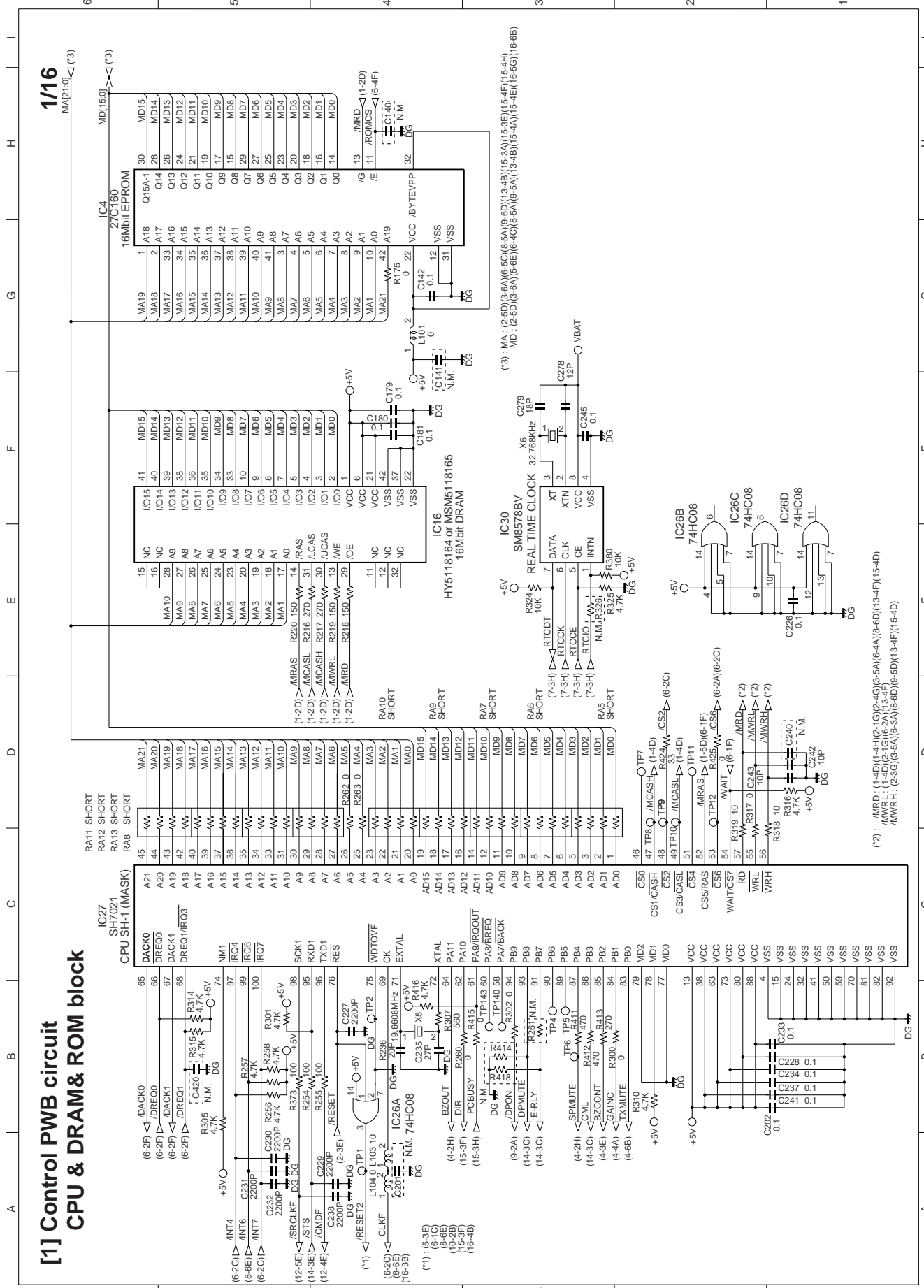

Reset & SRAM block

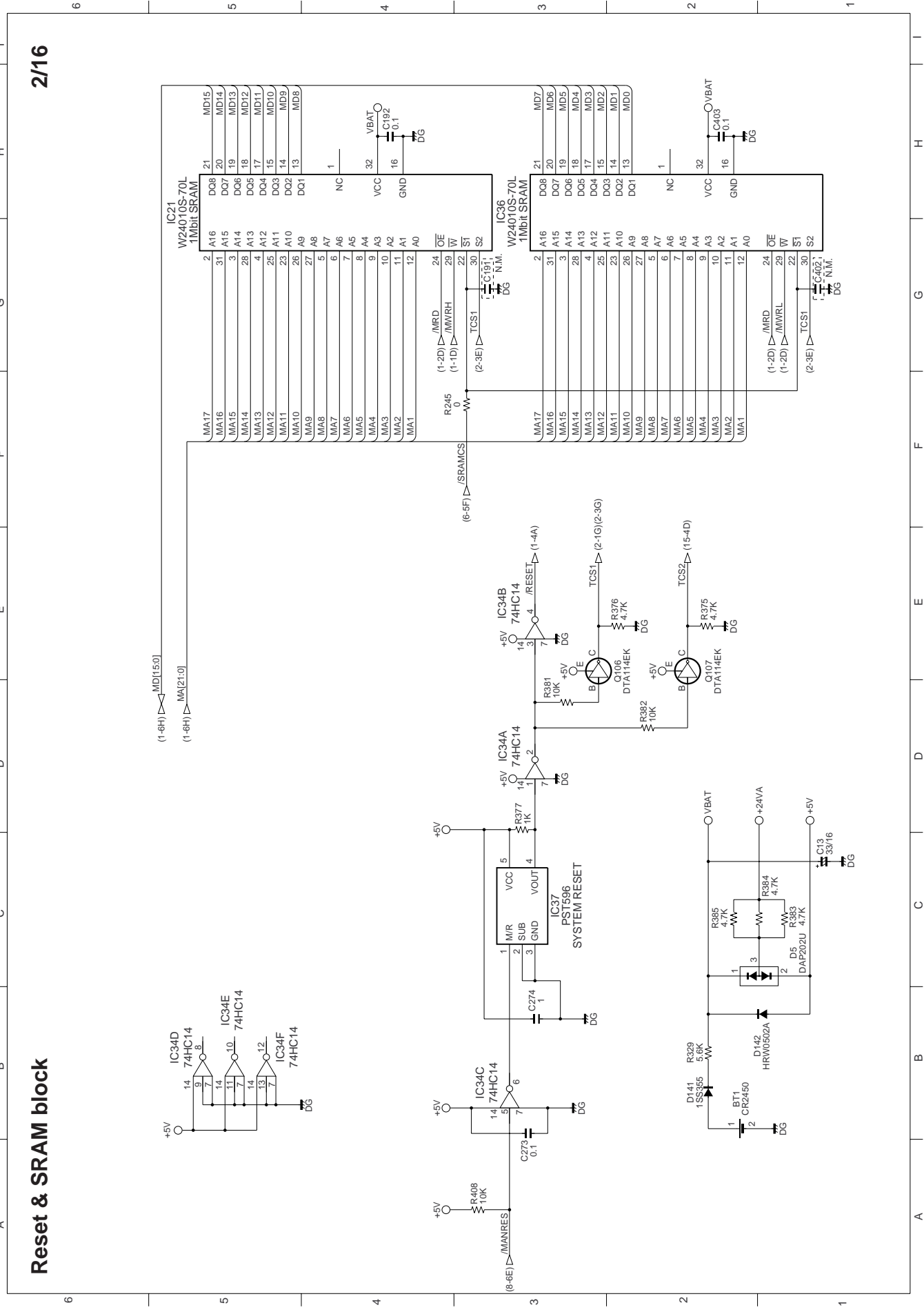

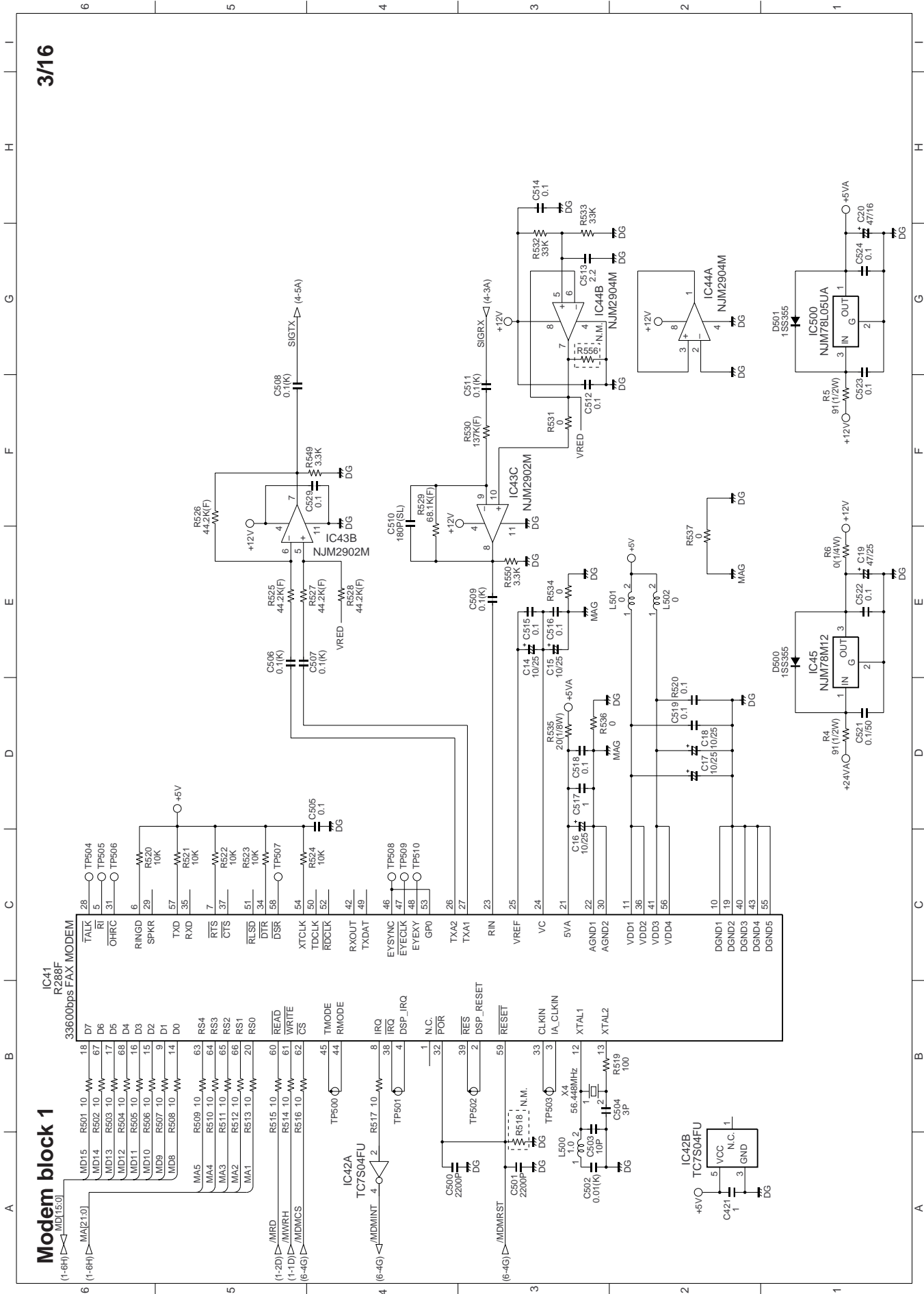

Modem block 1

IC41 R288F

33600bps FAX MODEM

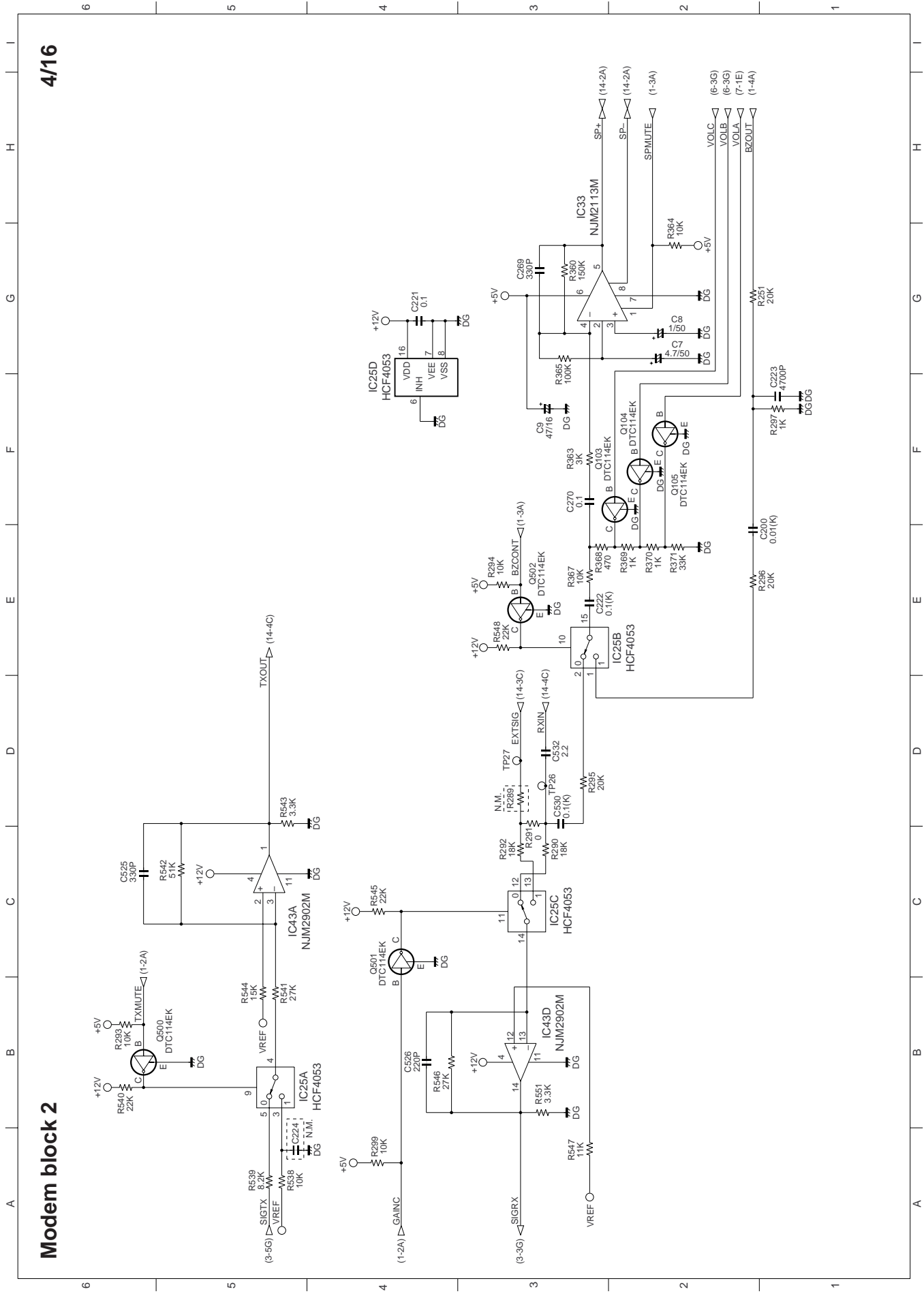

Modem block 2

Reading block

5/16

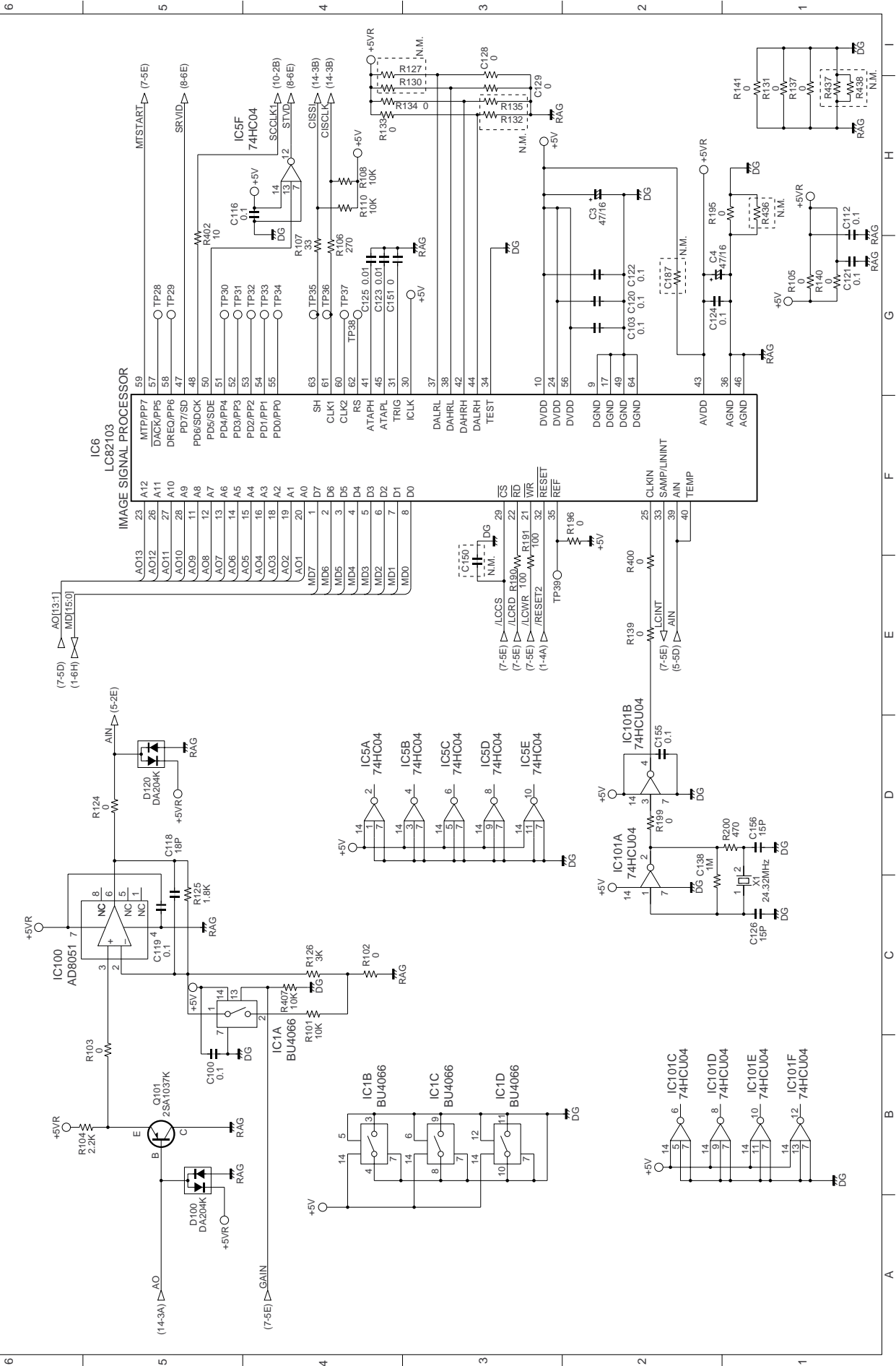

Gate array (A) block 2

7/16

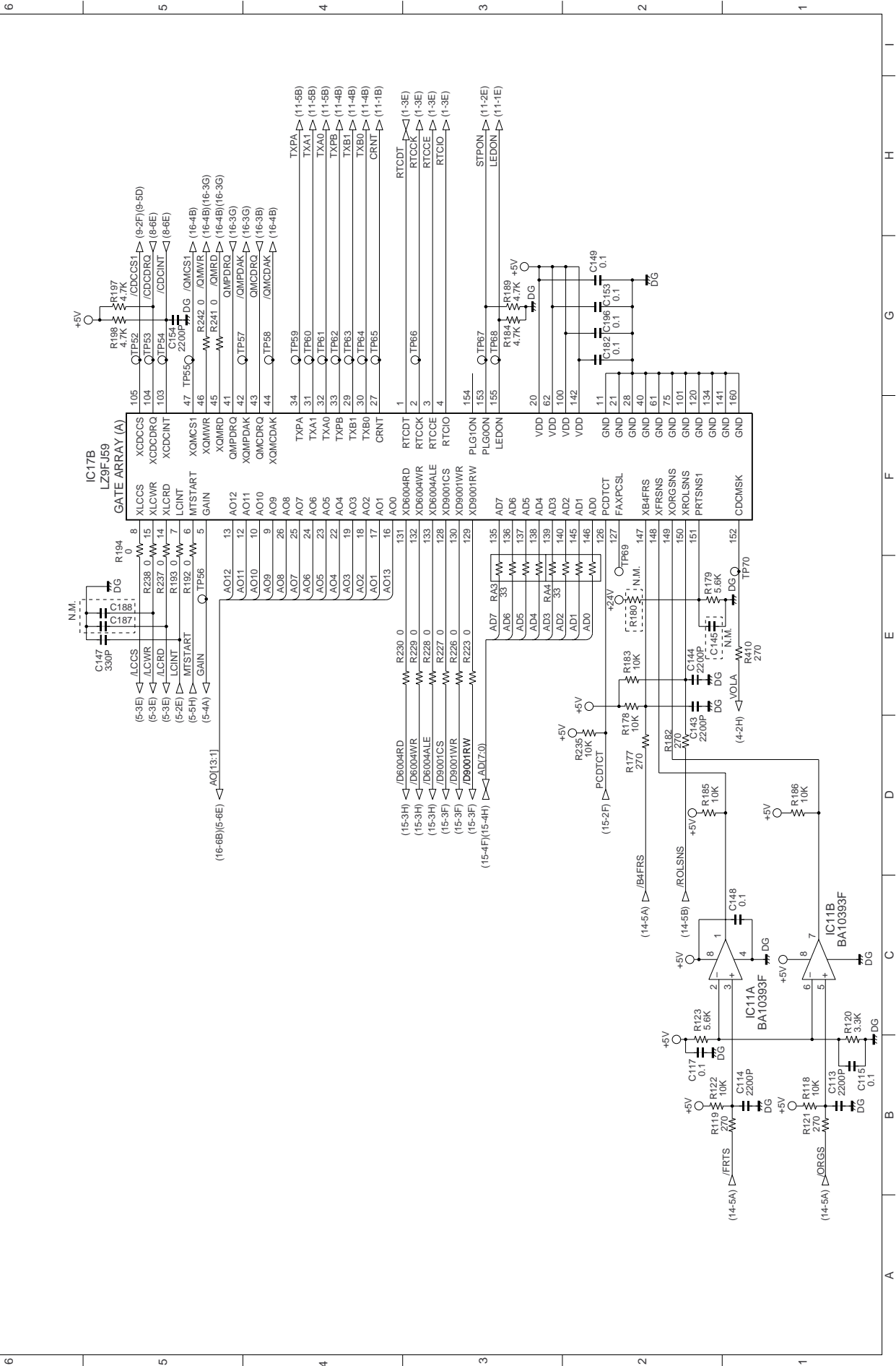

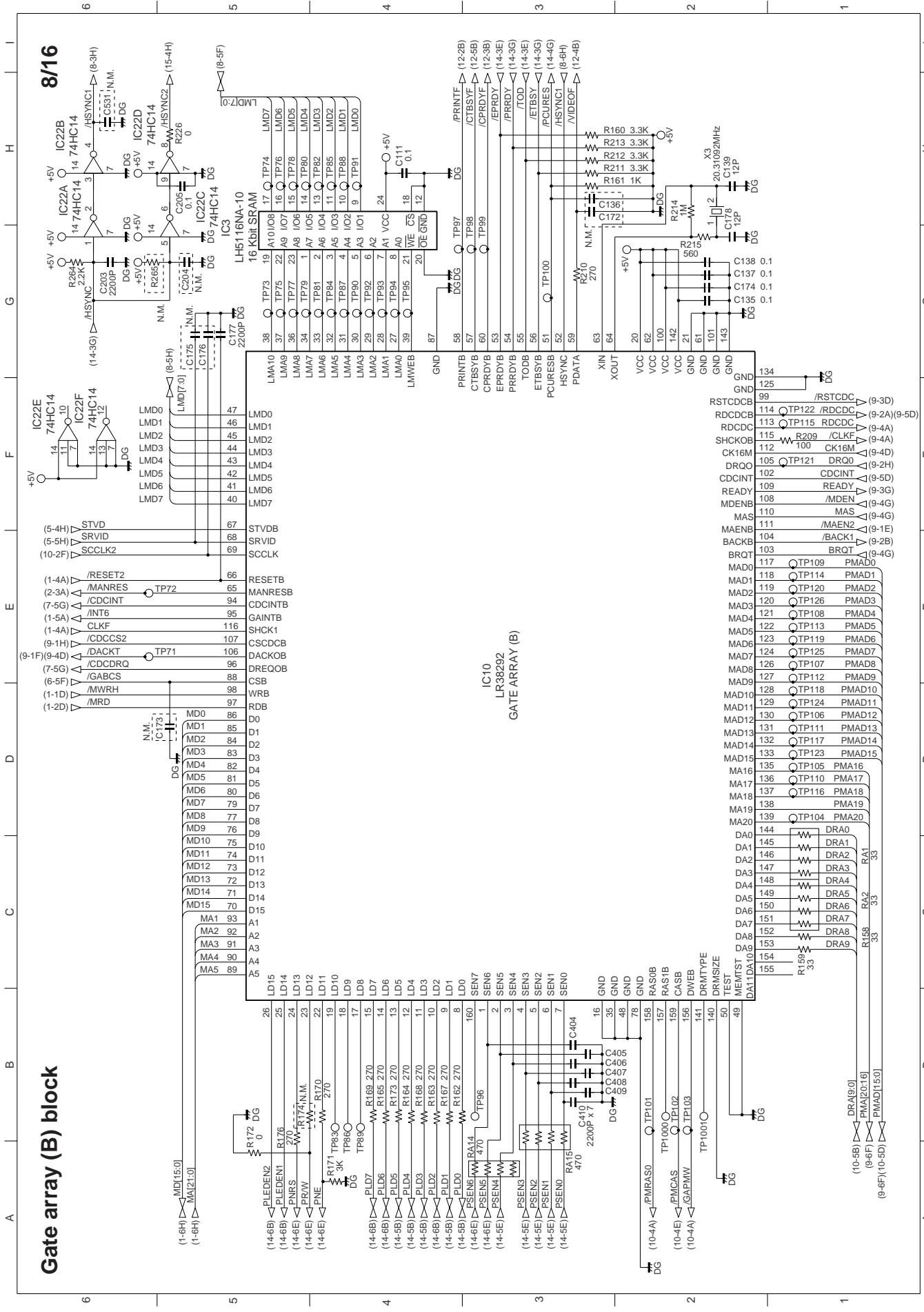

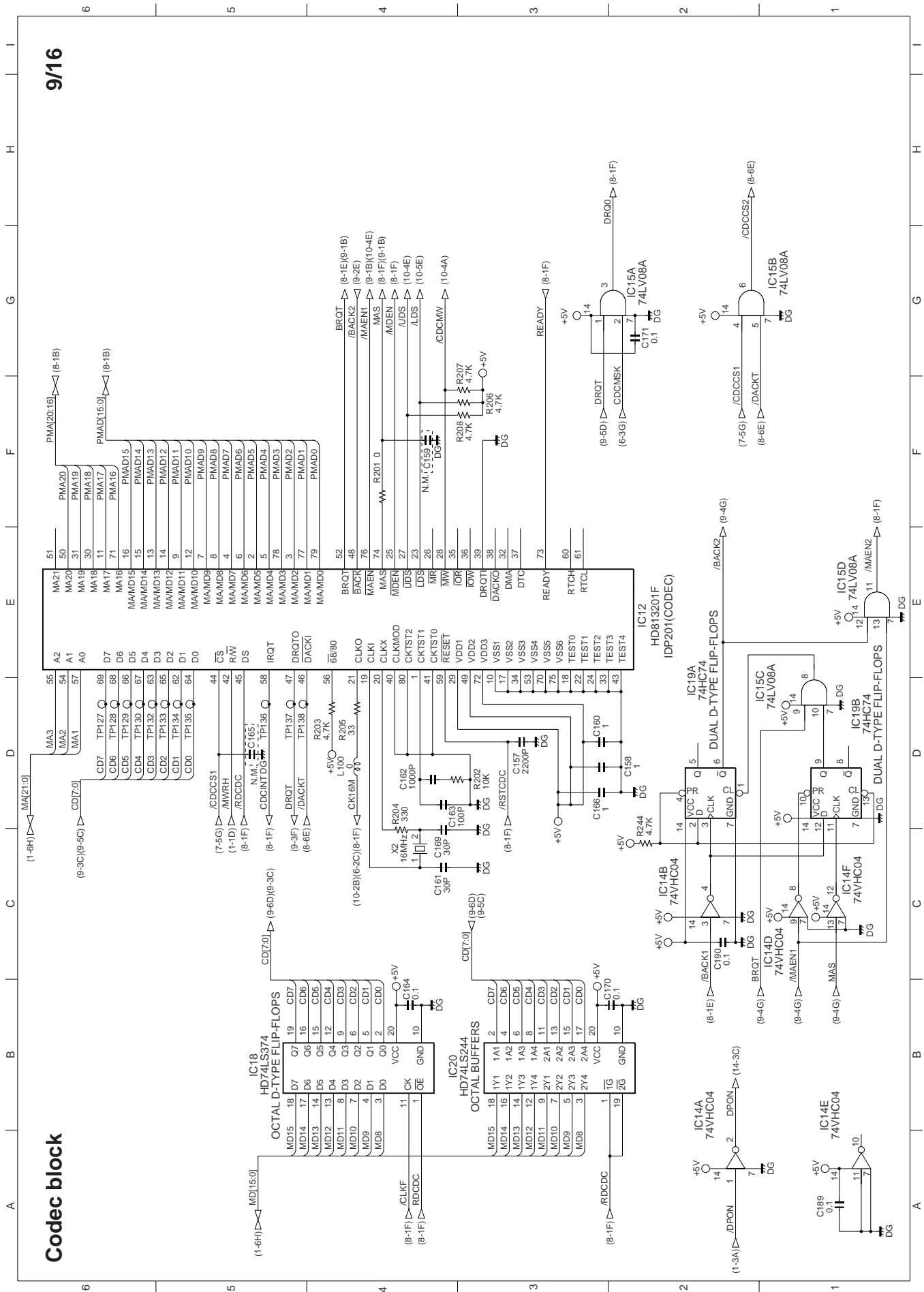

9/16

Codec block

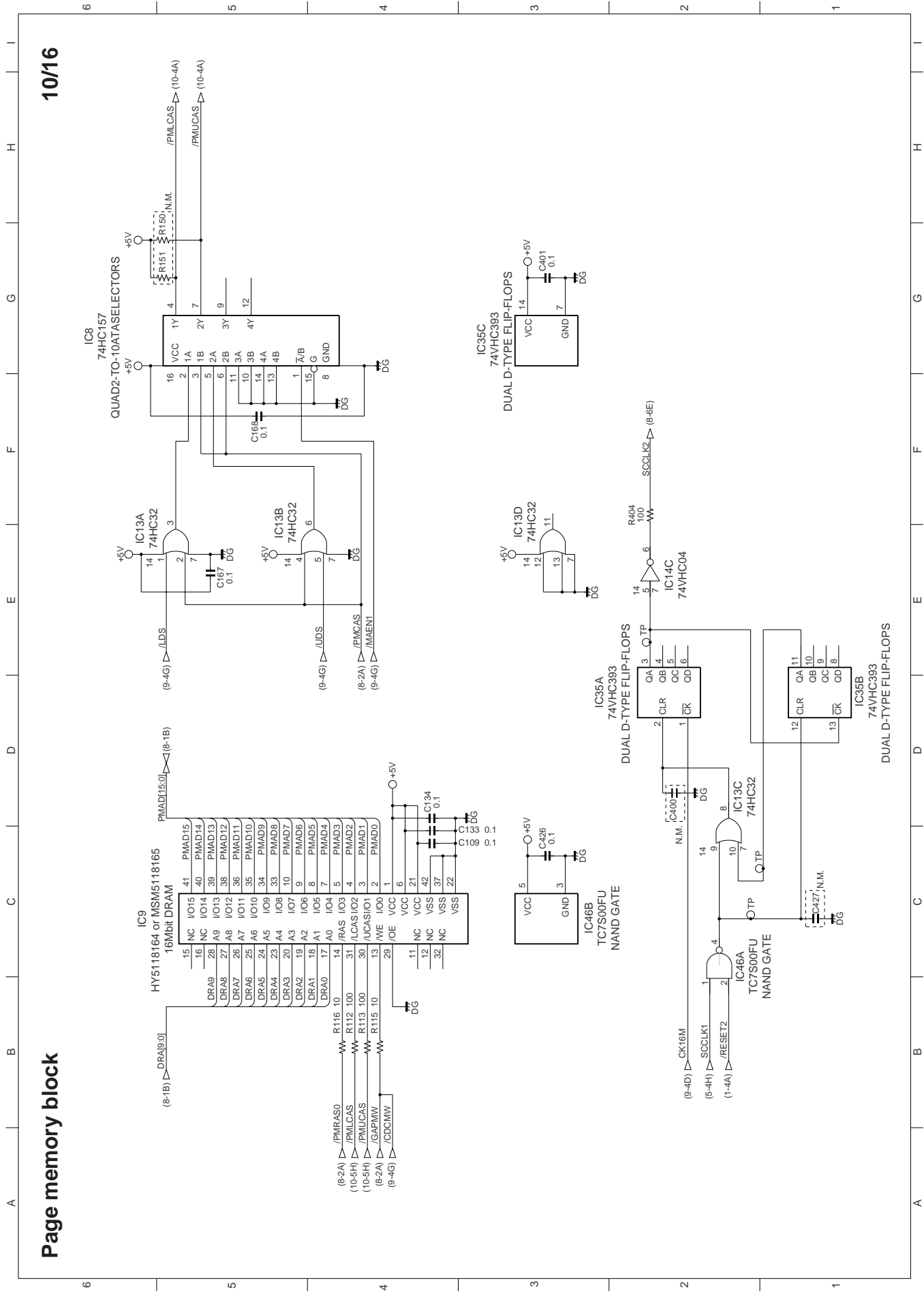

Page memory block

10/16

11/16

Drive & Power supply block

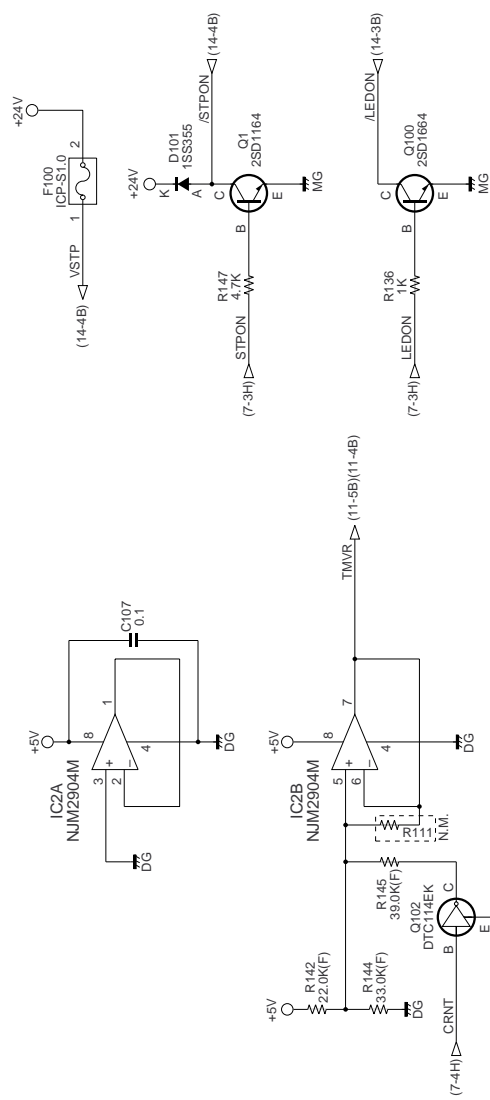
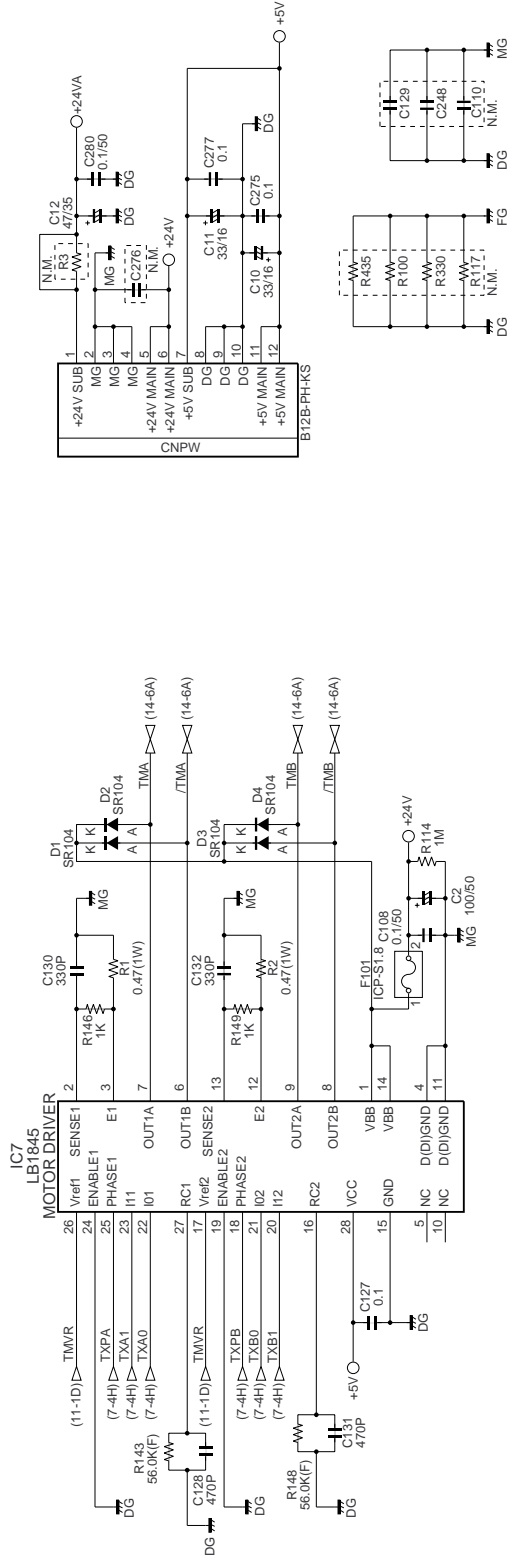

12/16

Selector block

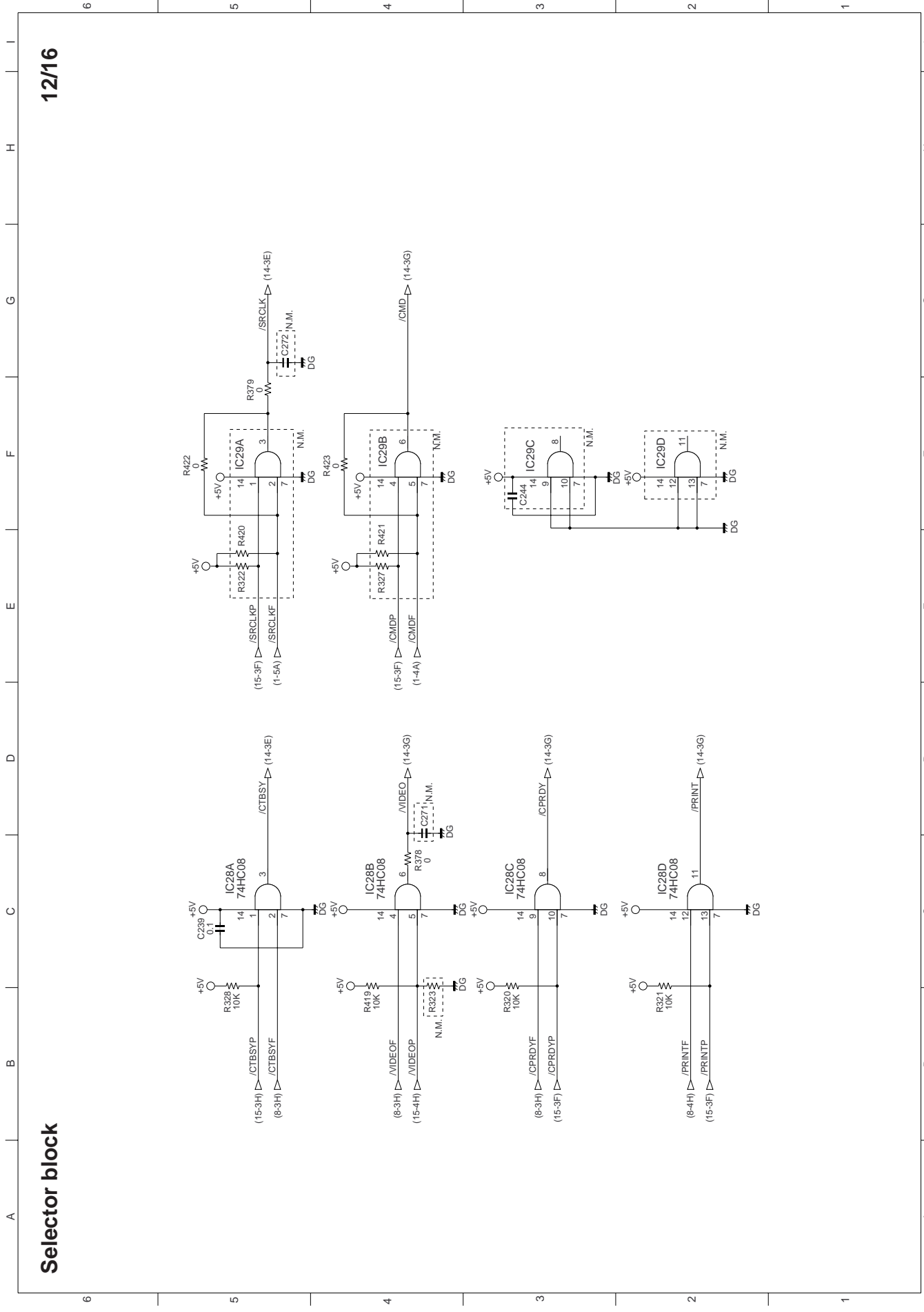

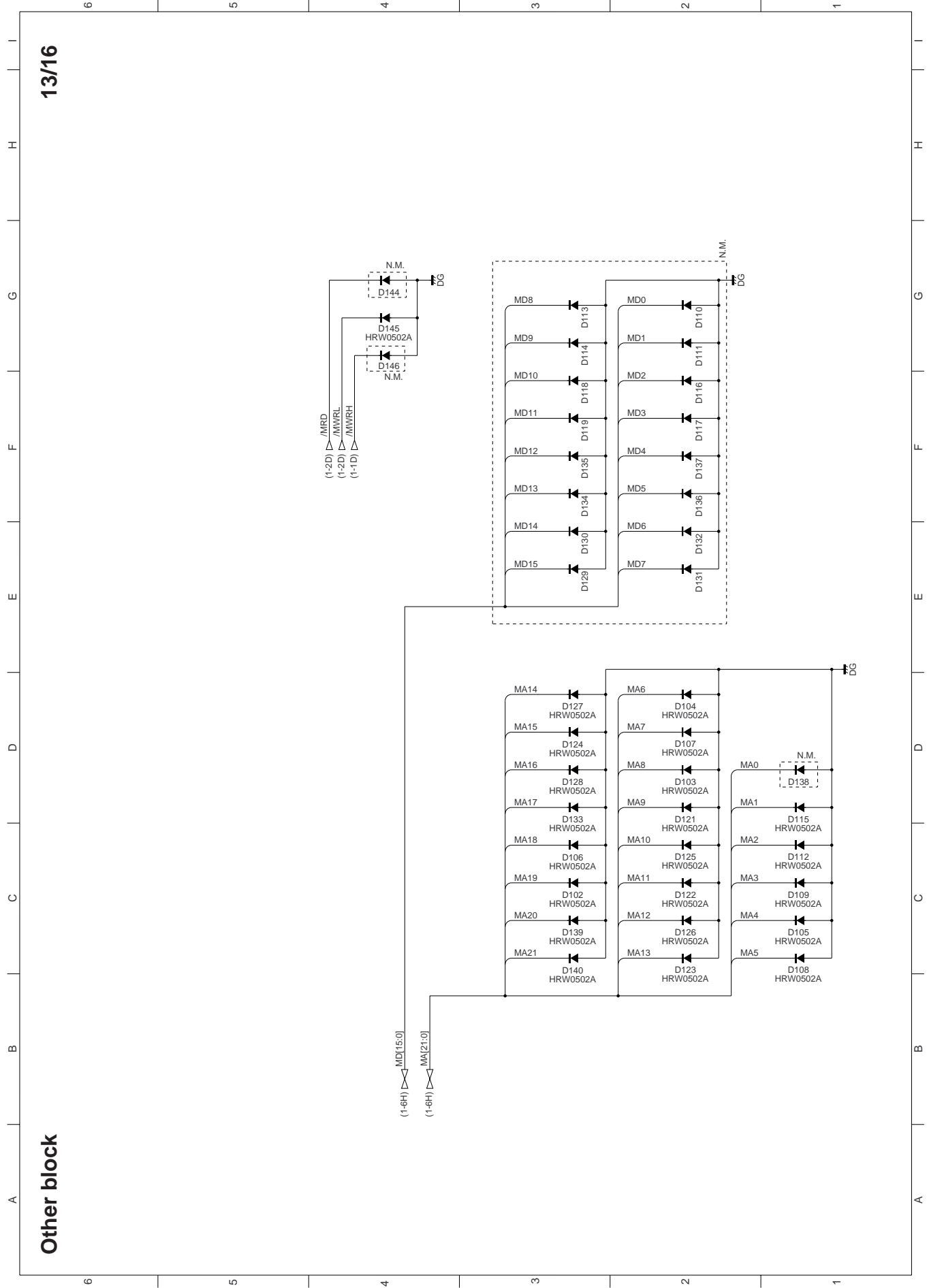

13/16

Other block

14/16

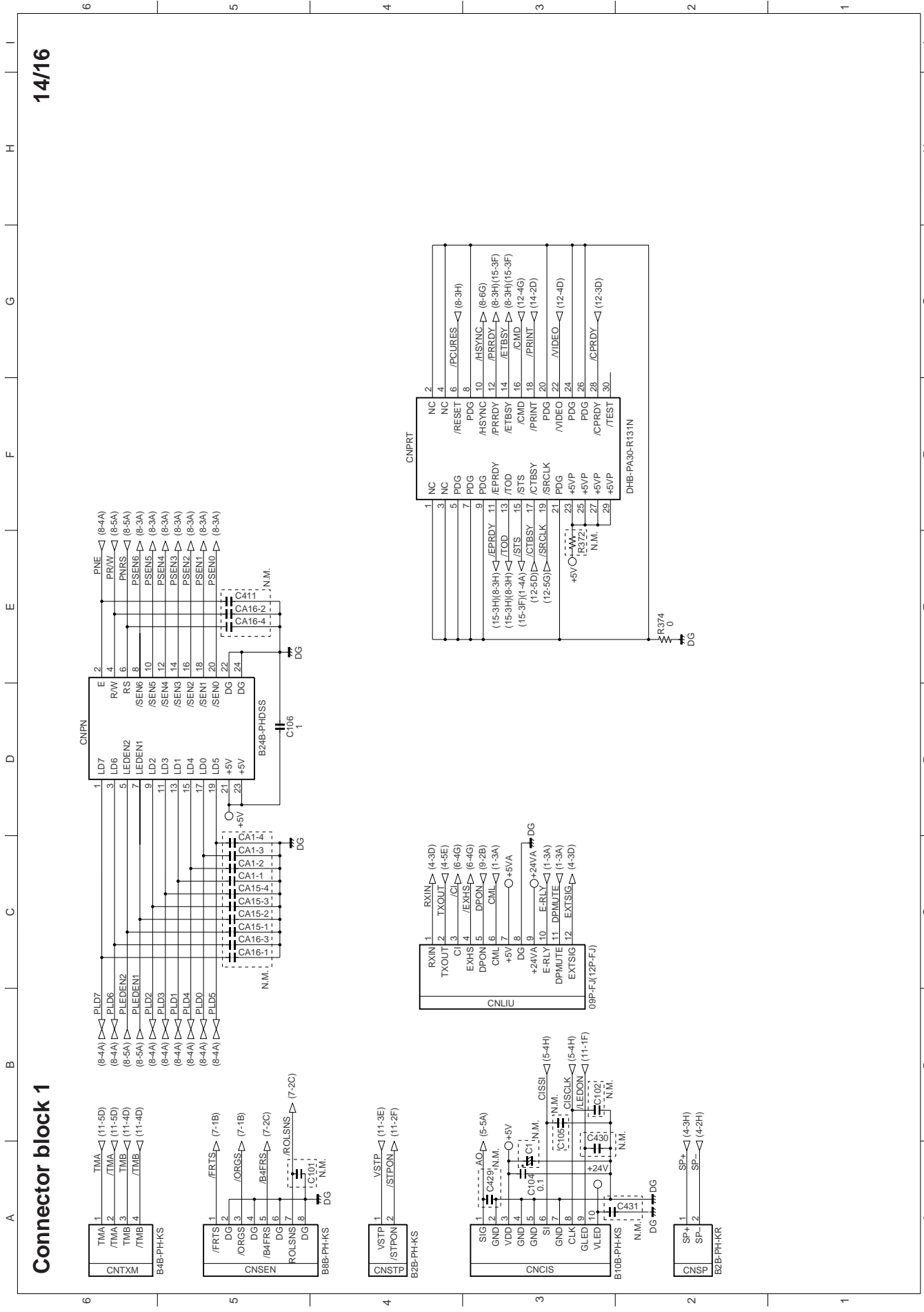

15/16

Connector block 2

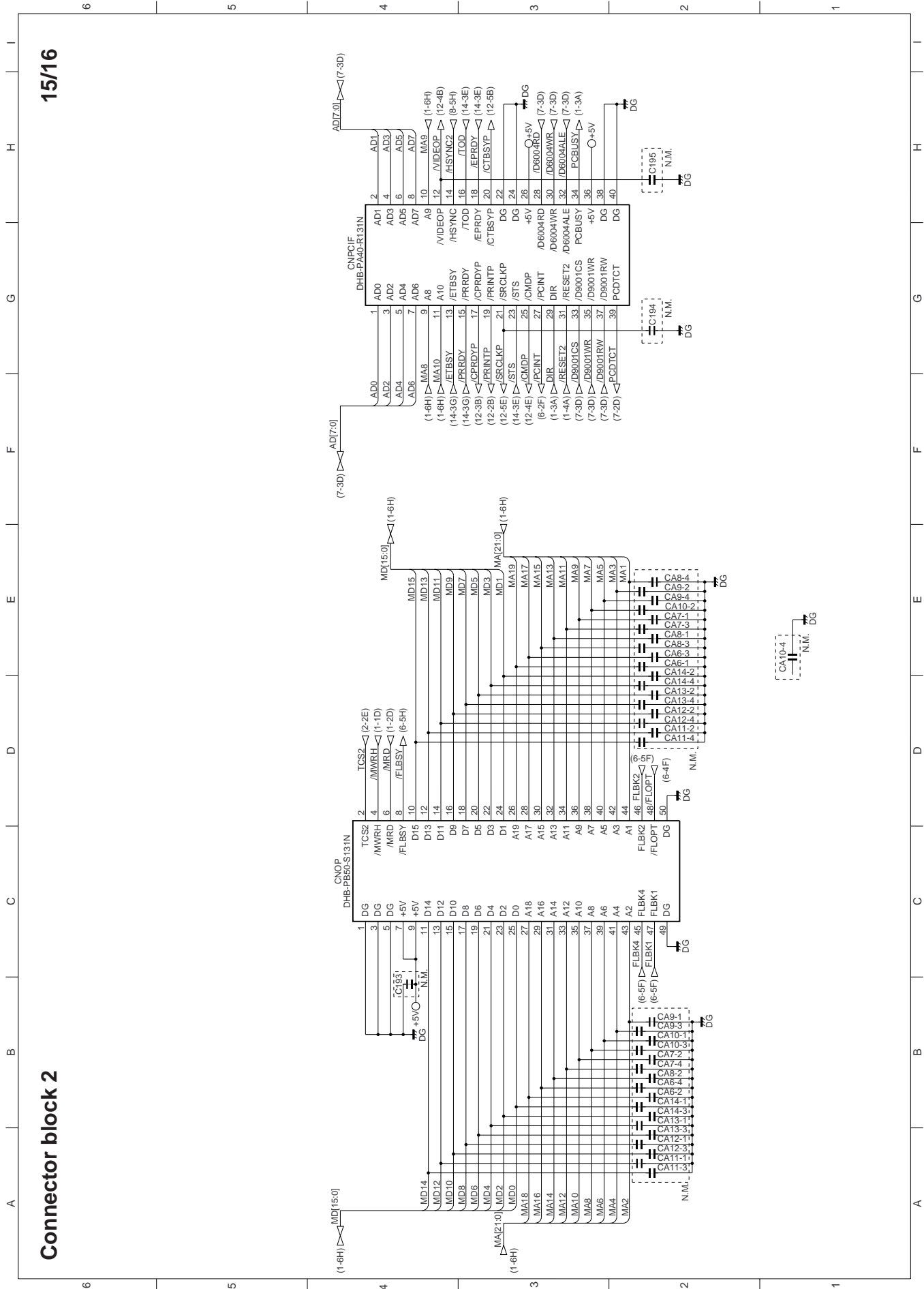

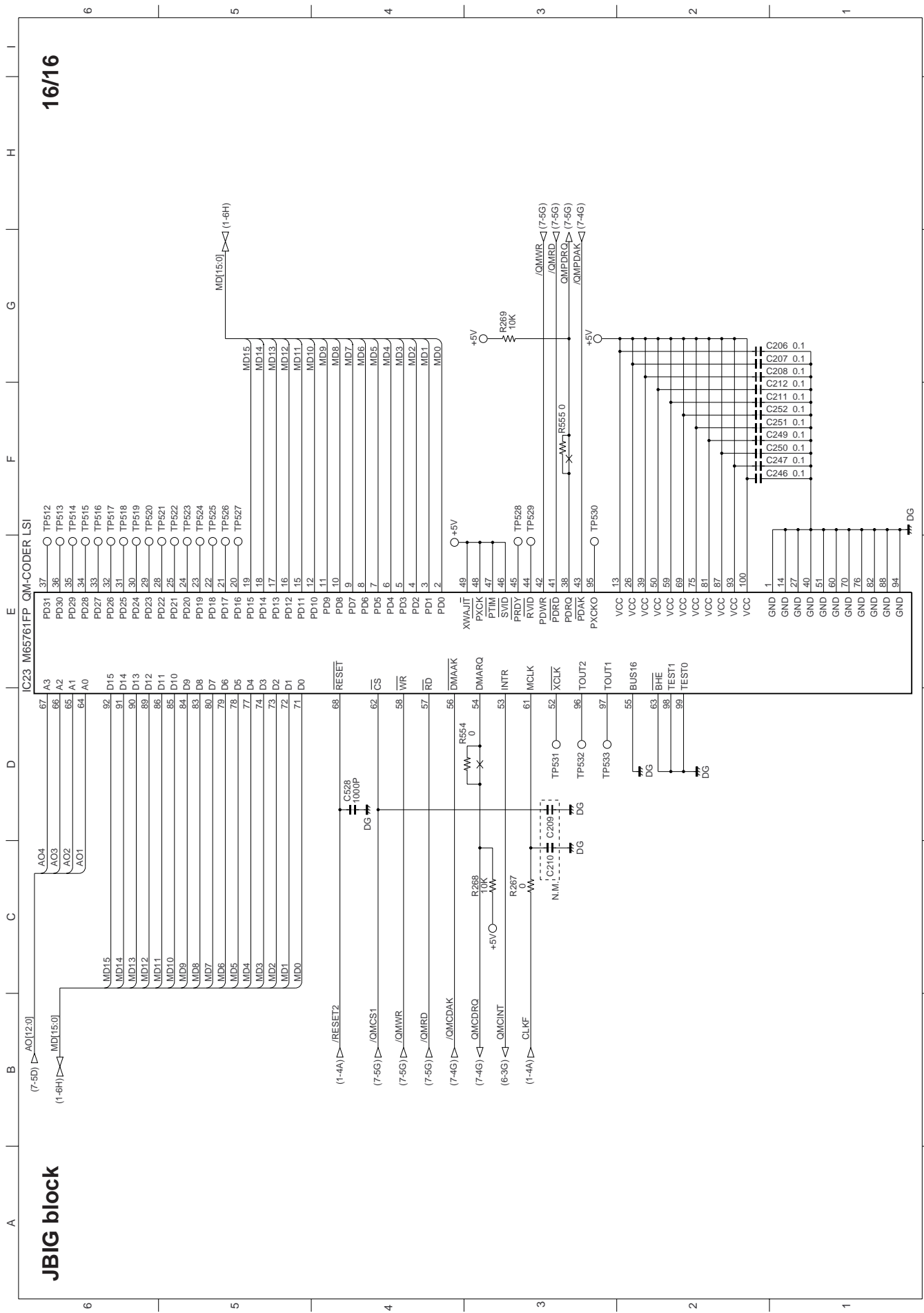

Control PWB parts layout (Top side)

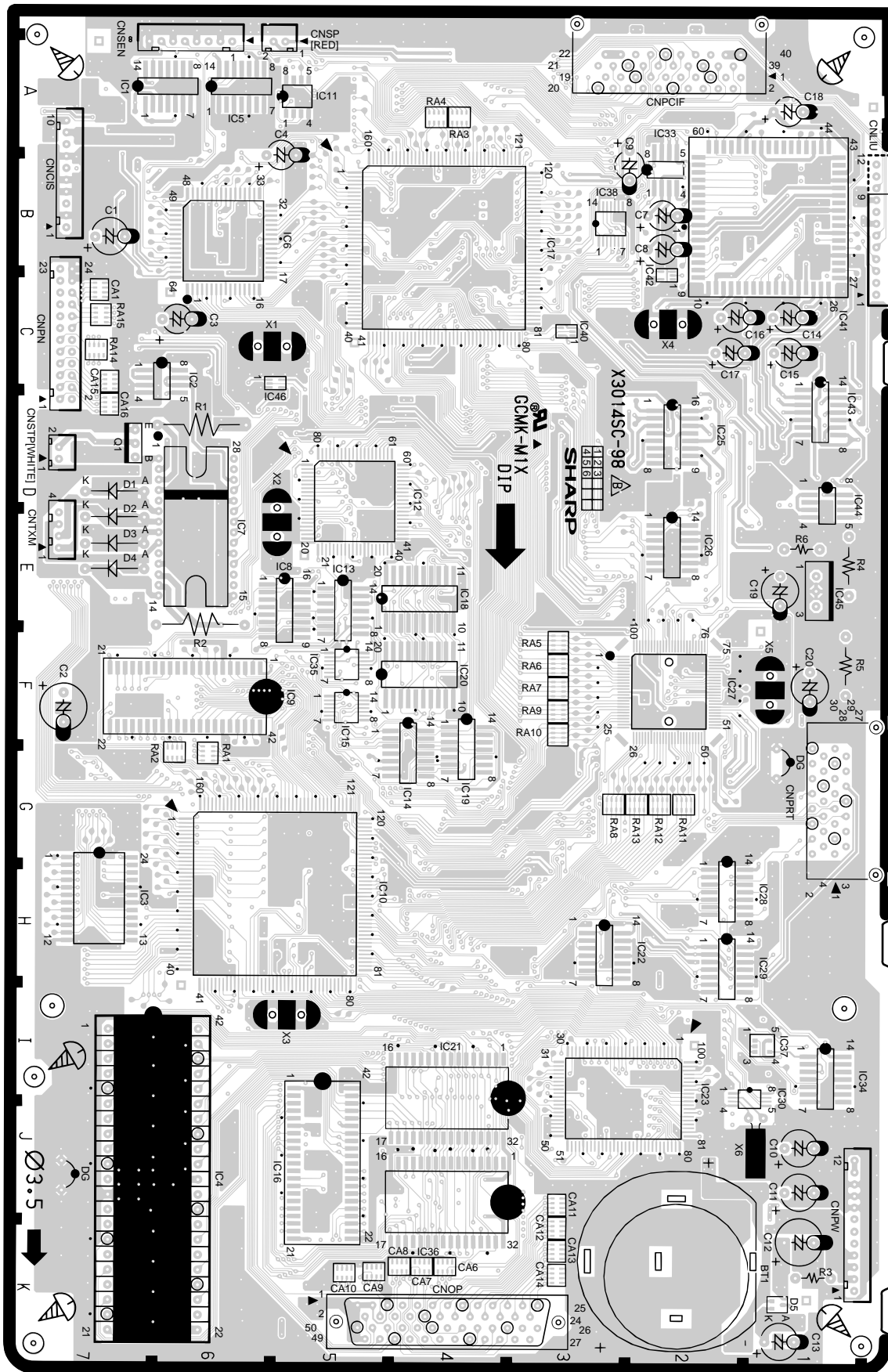

Control PWB parts layout (Bottom side)

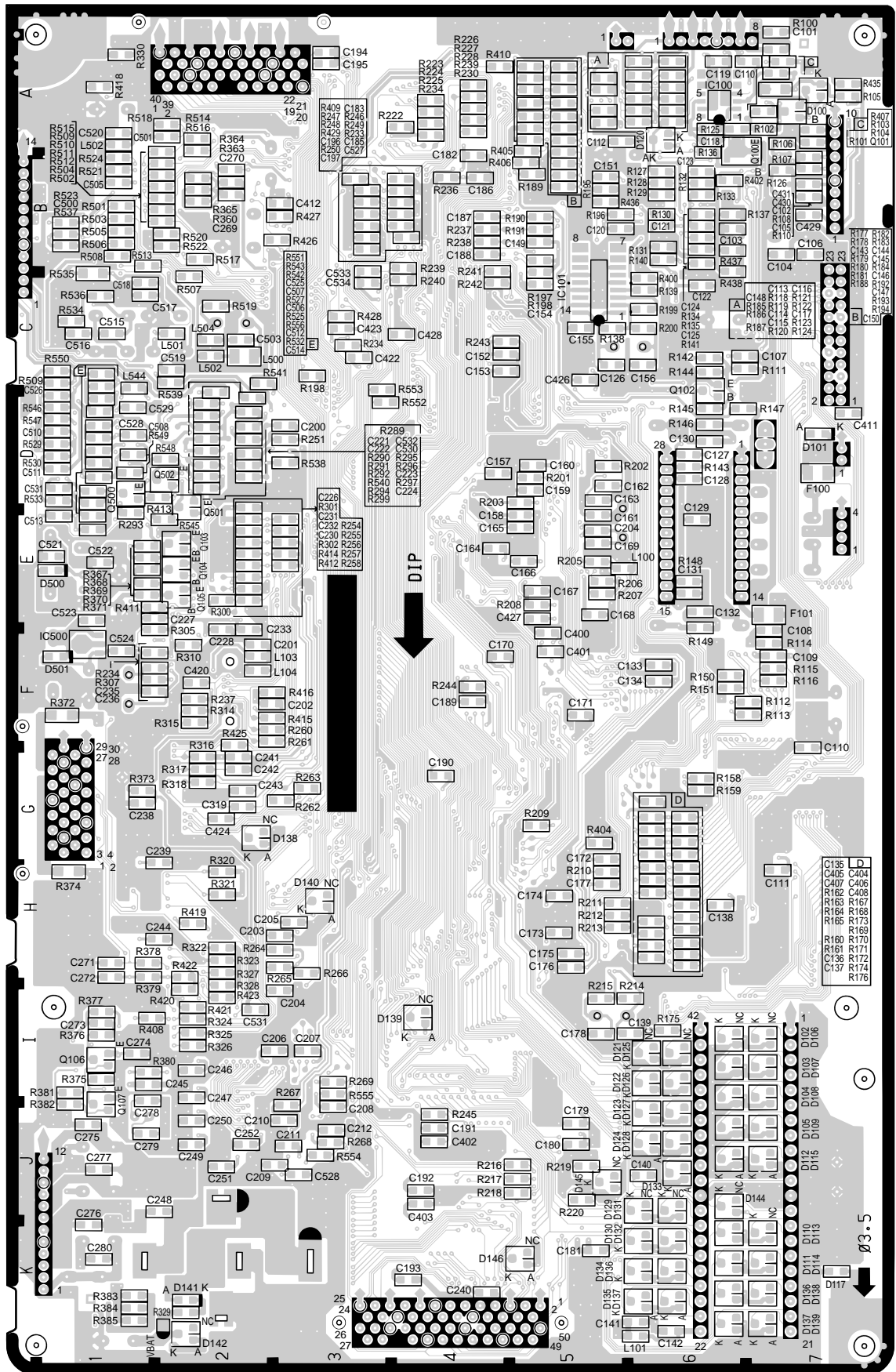

[2] LIU PWB circuit

1/1

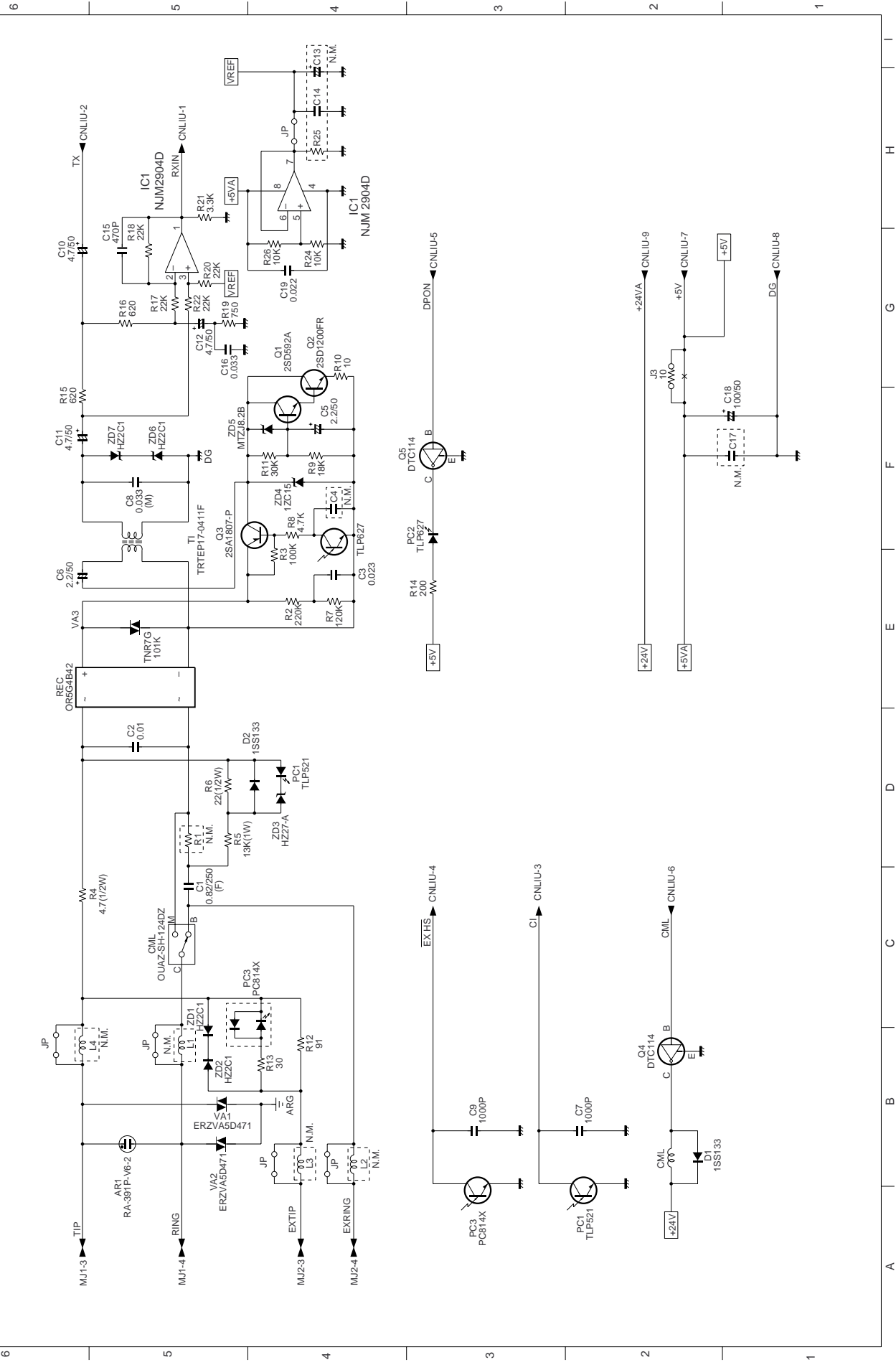

LIU PWB parts layout

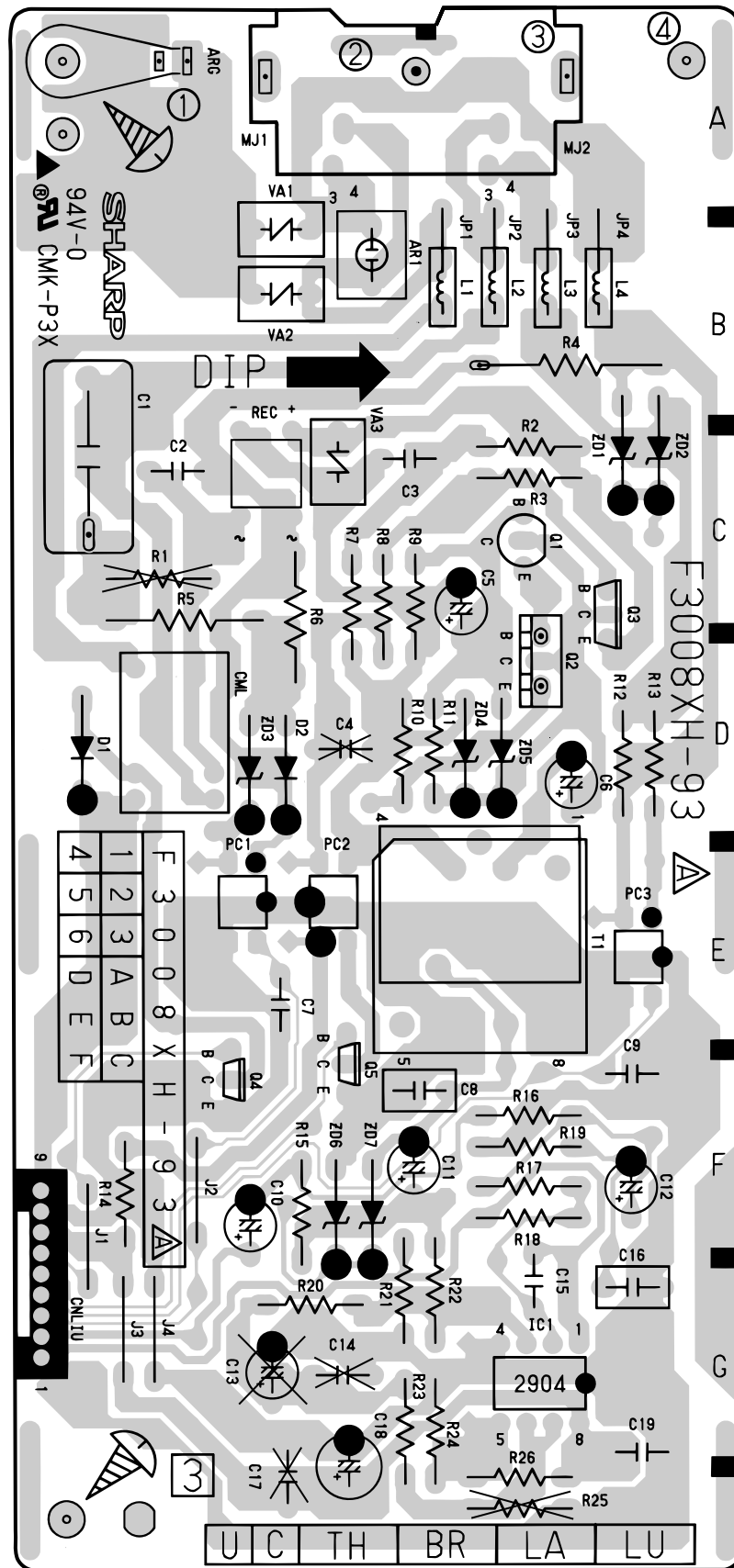

1/2

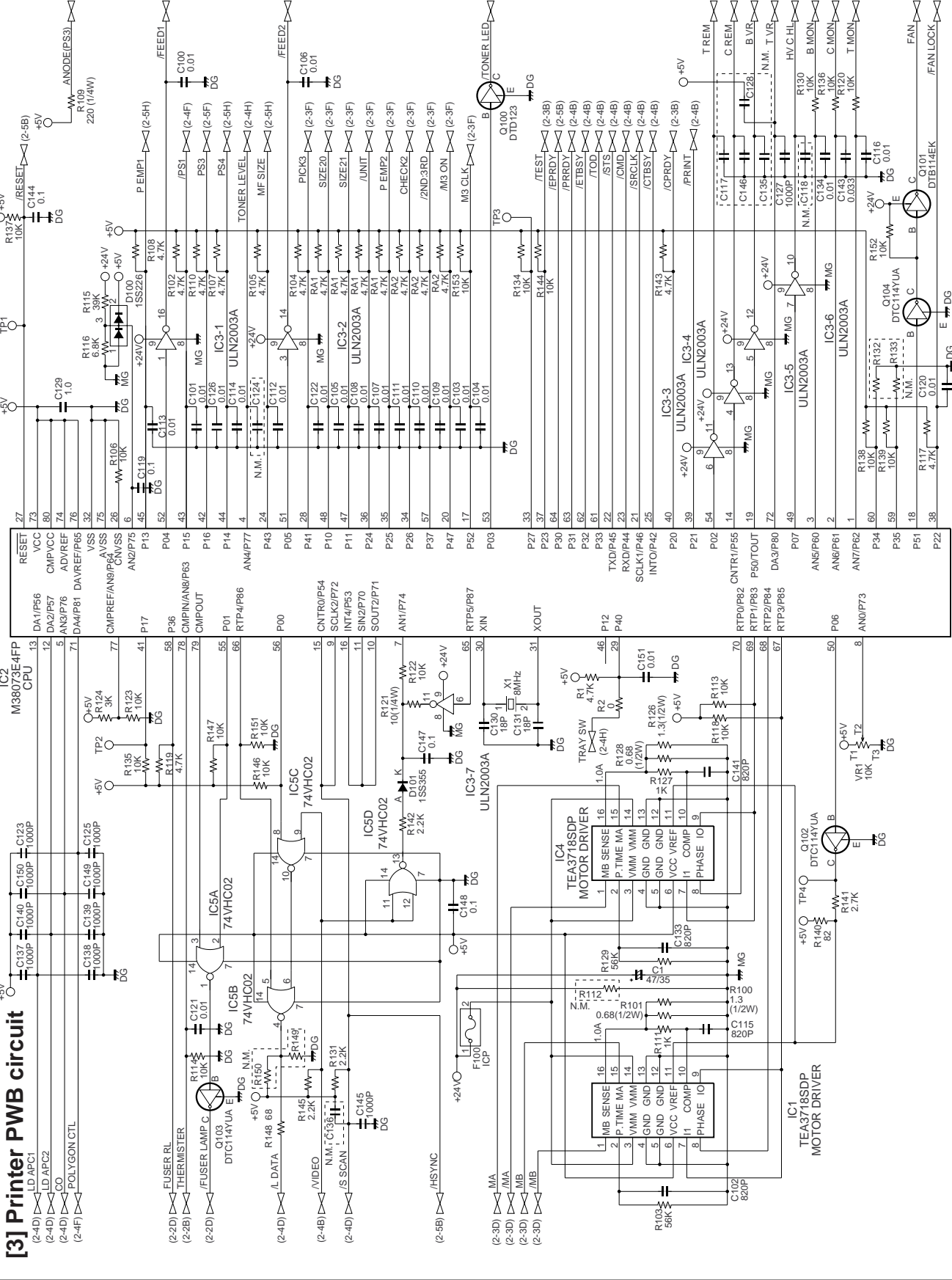

Printer PWB circuit

2/2

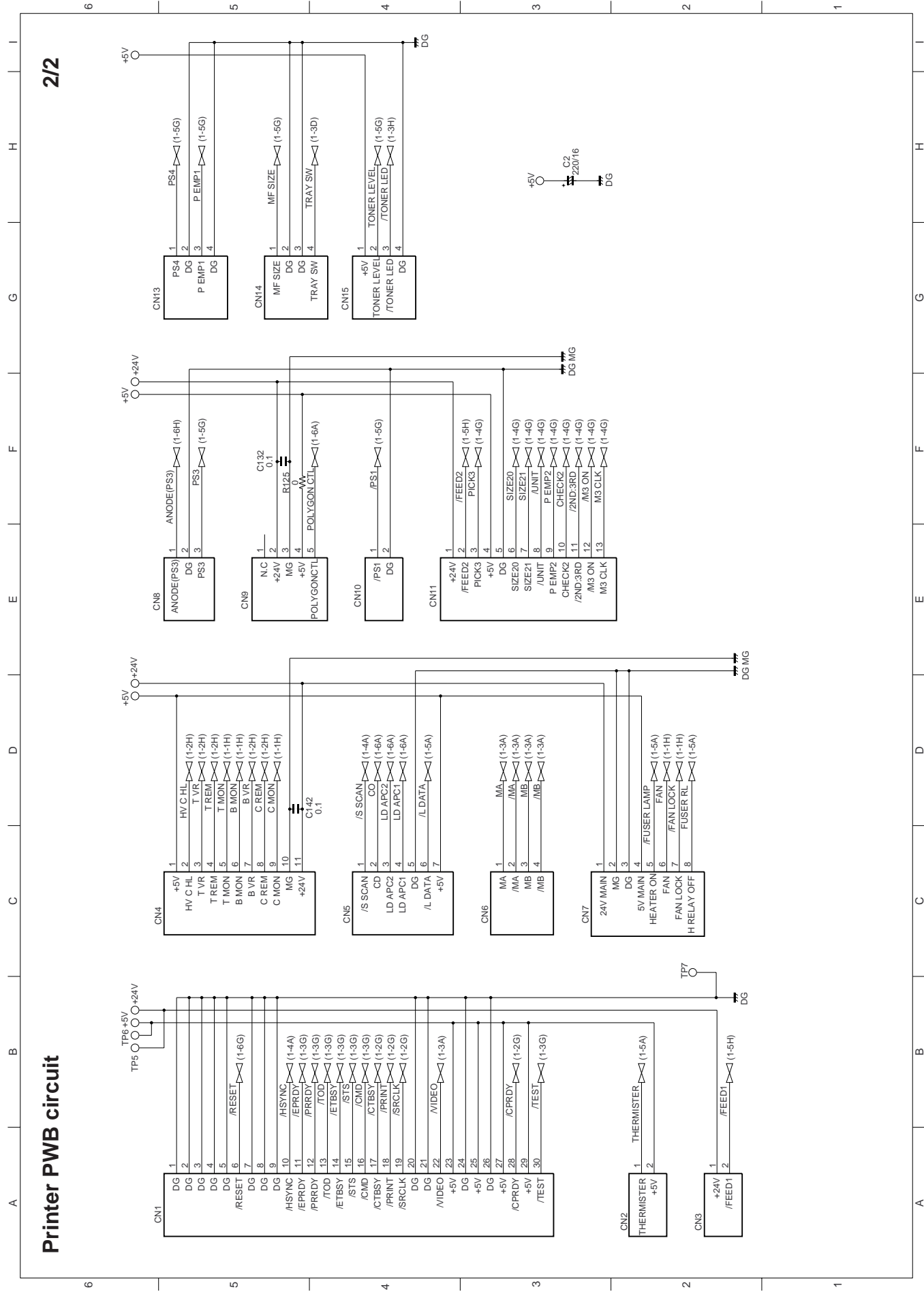

Printer PWB parts layout (Top side)

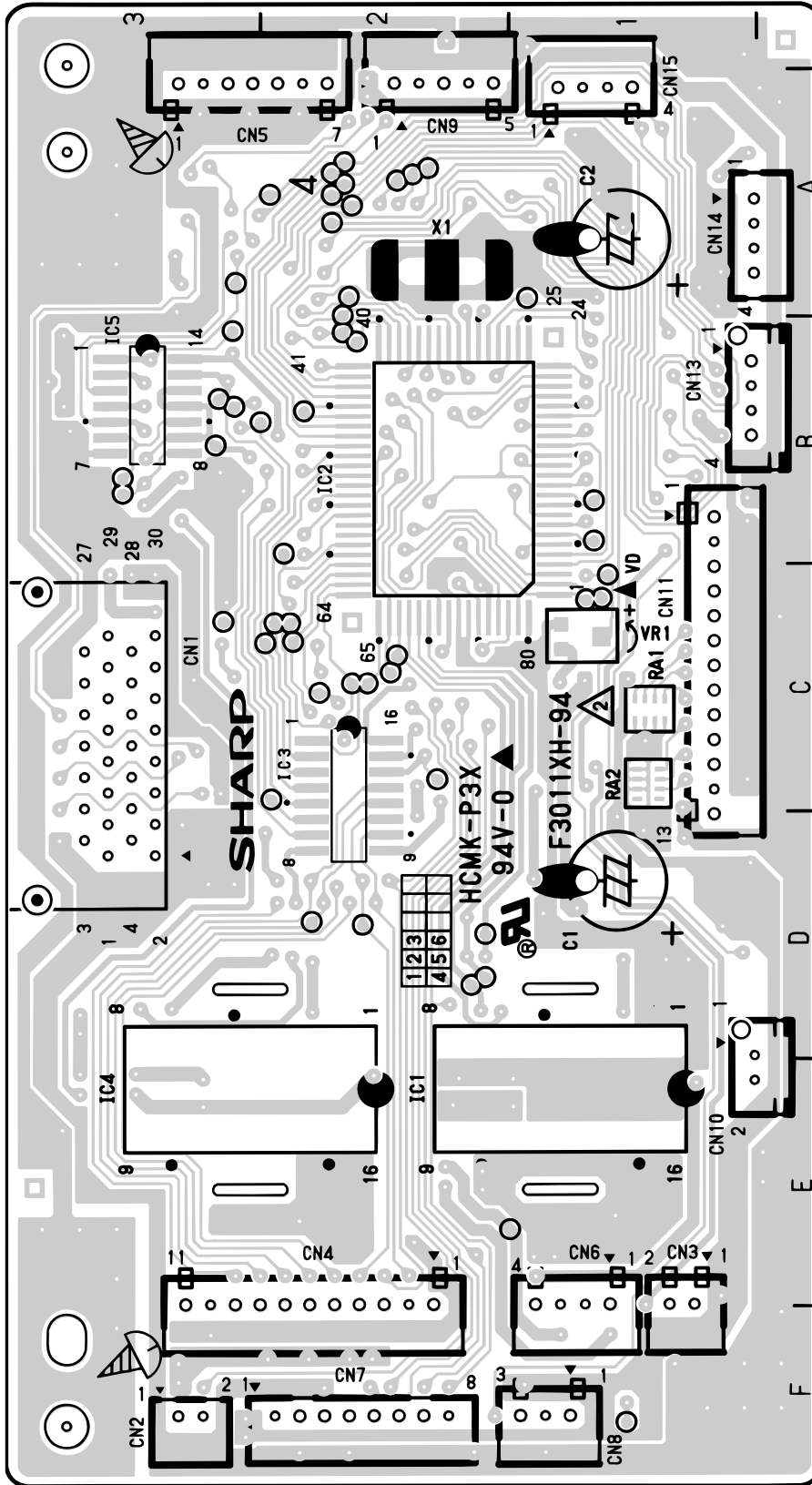

Printer PWB parts layout (Bottom side)

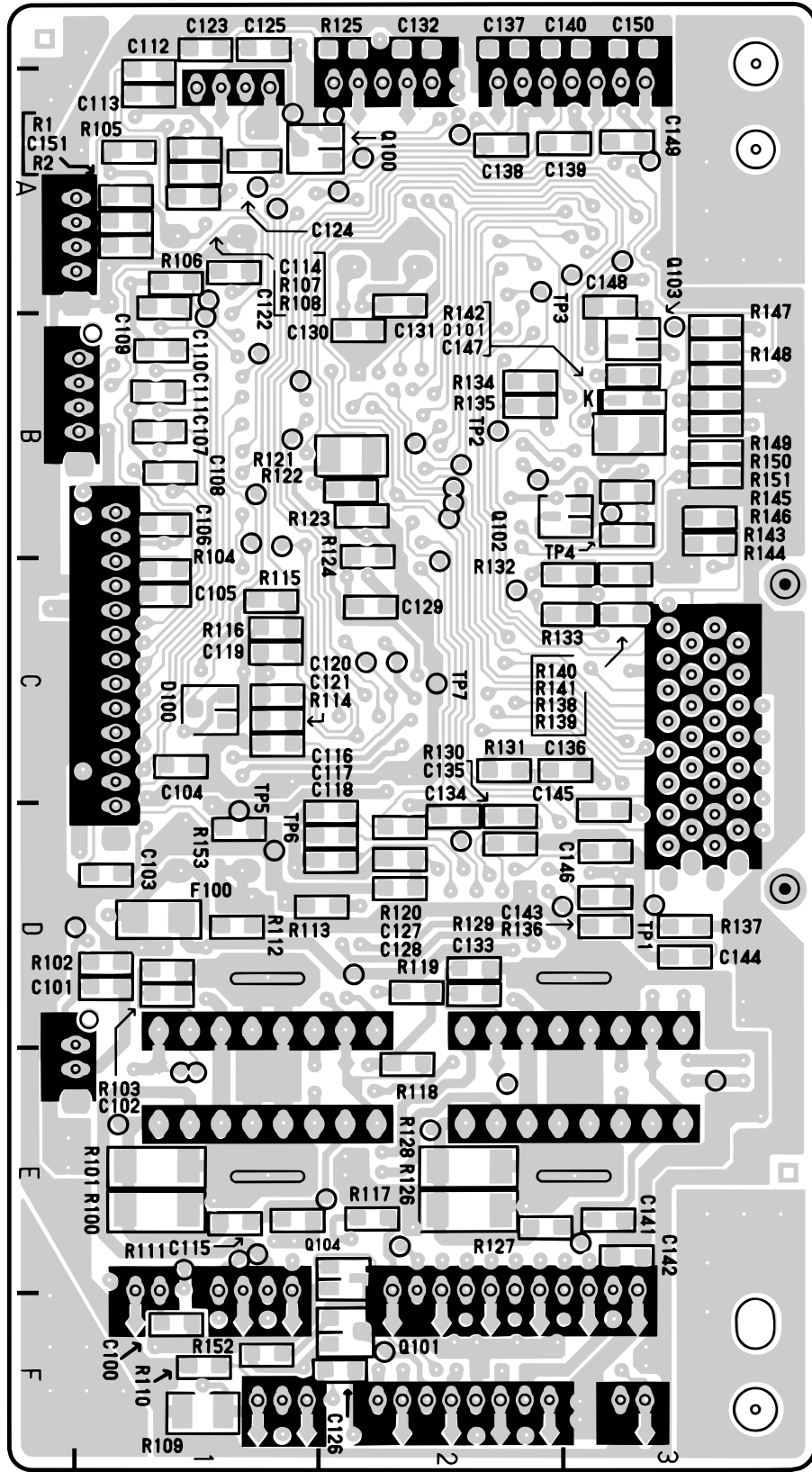

[4] Power supply PWB circuit

1/1

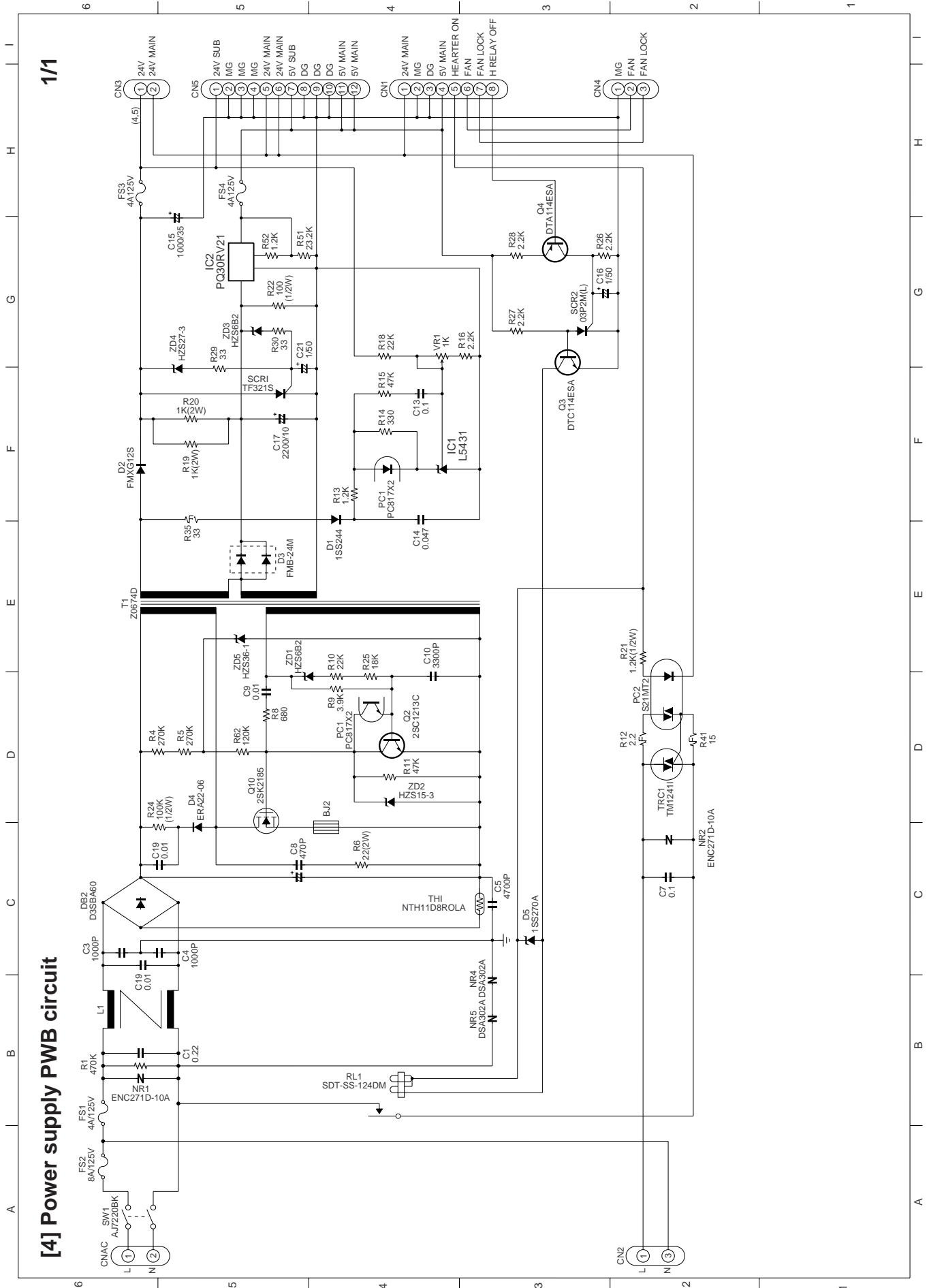

Power supply PWB parts layout

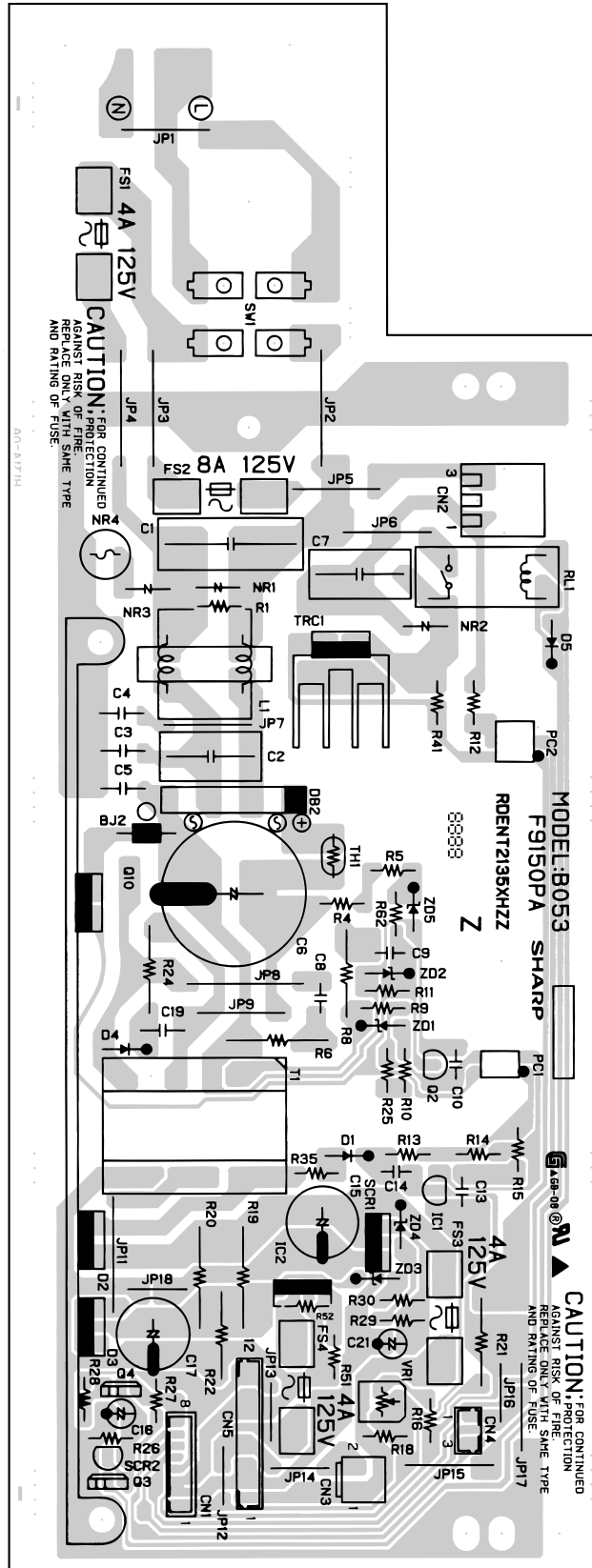

[5] Operation panel PWB circuit

1/2

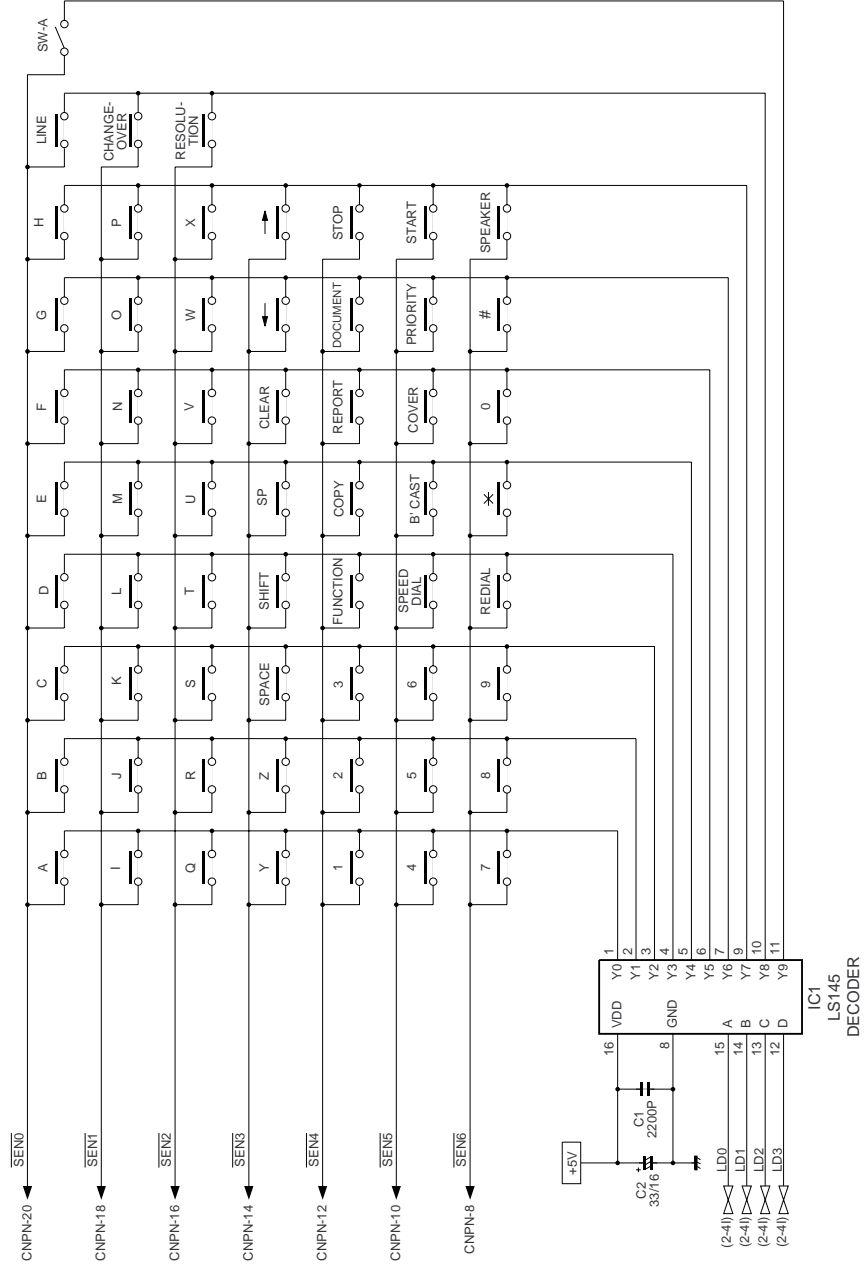

Note: Since the parts of this PWB cannot be supplied, change it as a unit.

Operation panel PWB circuit

2/2

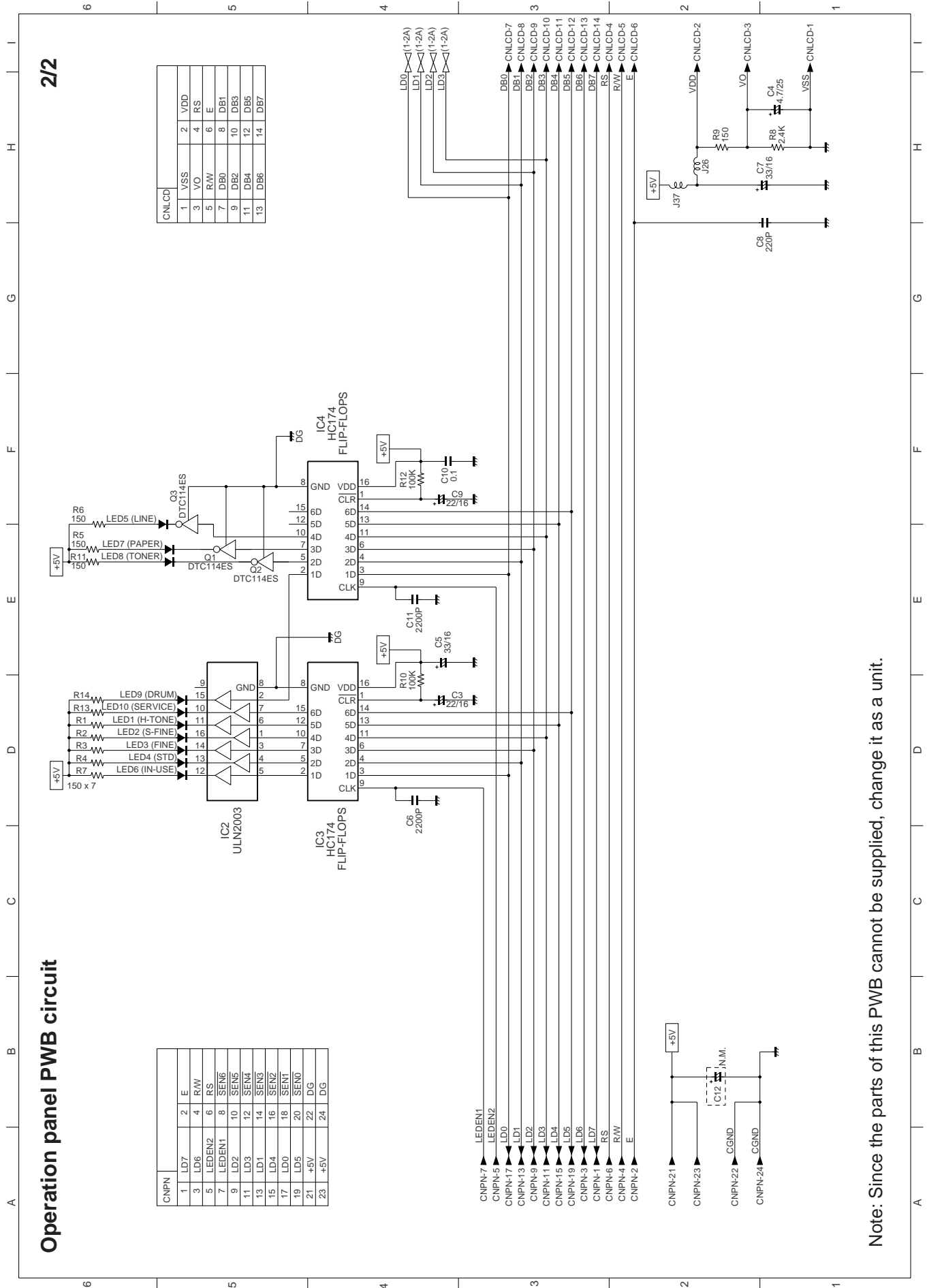

CNPN	1	LD7	2	E
	3	LD6	4	R/W
	5	LEDEN2	6	RS
	7	LEDEN1	8	SEN2
	9	LD2	10	SEN2
	11	LD3	12	SEN2
	13	LD1	14	SEN2
	15	LD4	16	SEN2
	17	LD0	18	SENT
	19	LD5	20	SEND
	21	+5V	22	DG
	23	+5V	24	DG

CNLOD	1	VSS	2	VDD
	3	VO	4	RS
	5	R/W	6	E
	7	DB0	8	DB1
	9	DB2	10	DB3
	11	DB4	12	DB5
	13	DB6	14	DB7

- CNPN-7 LEDEN1
- CNPN-8 LEDEN2
- CNPN-5 LD0
- CNPN-17 LD1
- CNPN-13 LD2
- CNPN-9 LD3
- CNPN-11 LD4
- CNPN-15 LD5
- CNPN-19 LD6
- CNPN-3 LD7
- CNPN-1 RS
- CNPN-6 R/W
- CNPN-4 E
- CNPN-2 E
- CNPN-21 +5V
- CNPN-23 +5V
- CNPN-22 CGND
- CNPN-24 CGND

Note: Since the parts of this PWB cannot be supplied, change it as a unit.

1/1

[6] High voltage PWB circuit

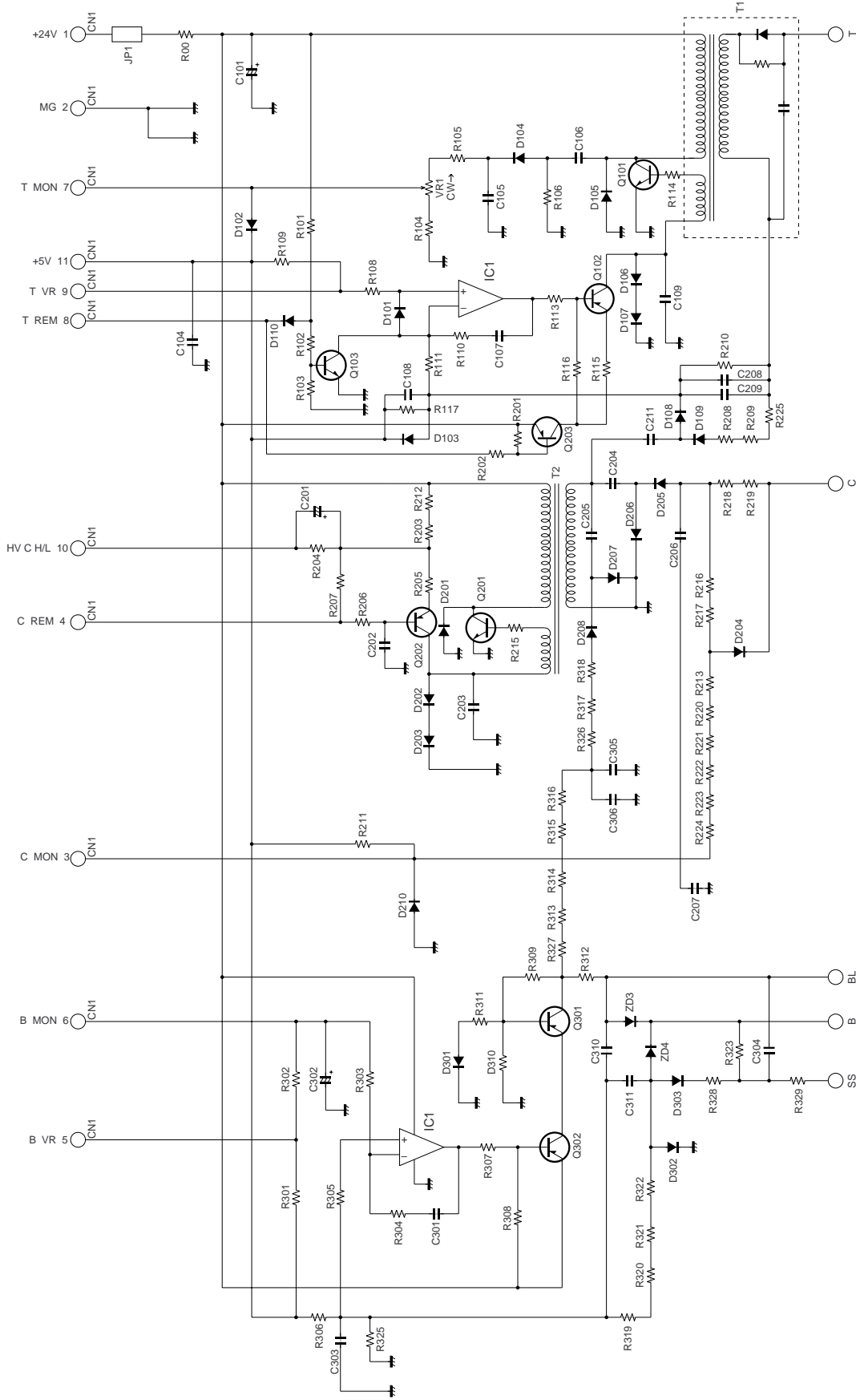

Note: Since the parts of this PWB cannot be supplied, change it as a unit.

High voltage PWB parts layout

Note: Since the parts of this PWB cannot be supplied, change it as a unit.

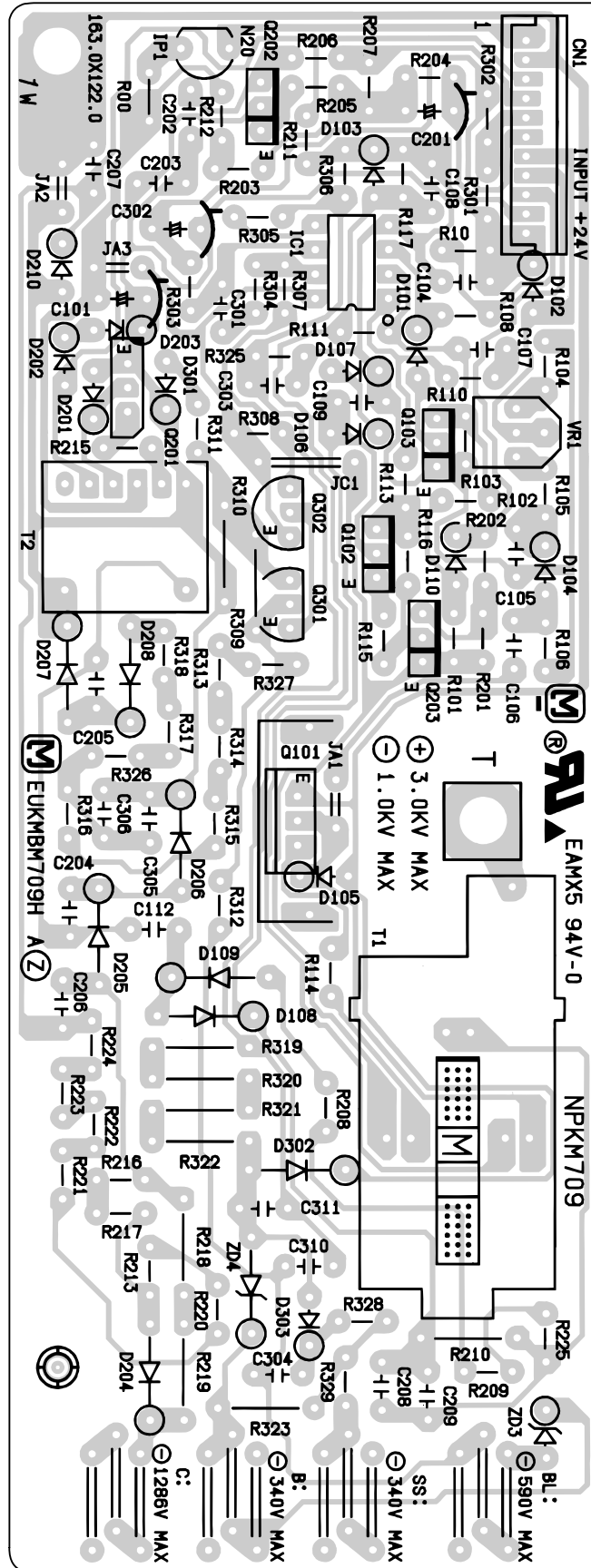

[7] Toner empty PWB circuit

1/1

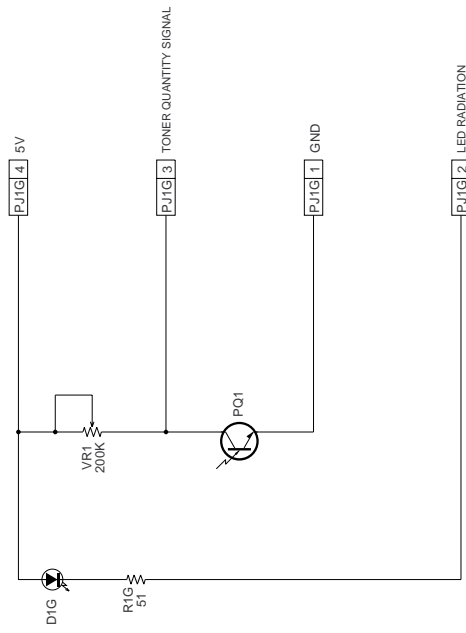

Toner empty PWB parts layout

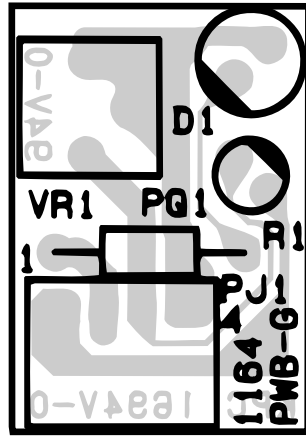

Note: Since the parts of this PWB cannot be supplied, change it as a unit.

[8] 2nd. cassette PWB circuit

1/1

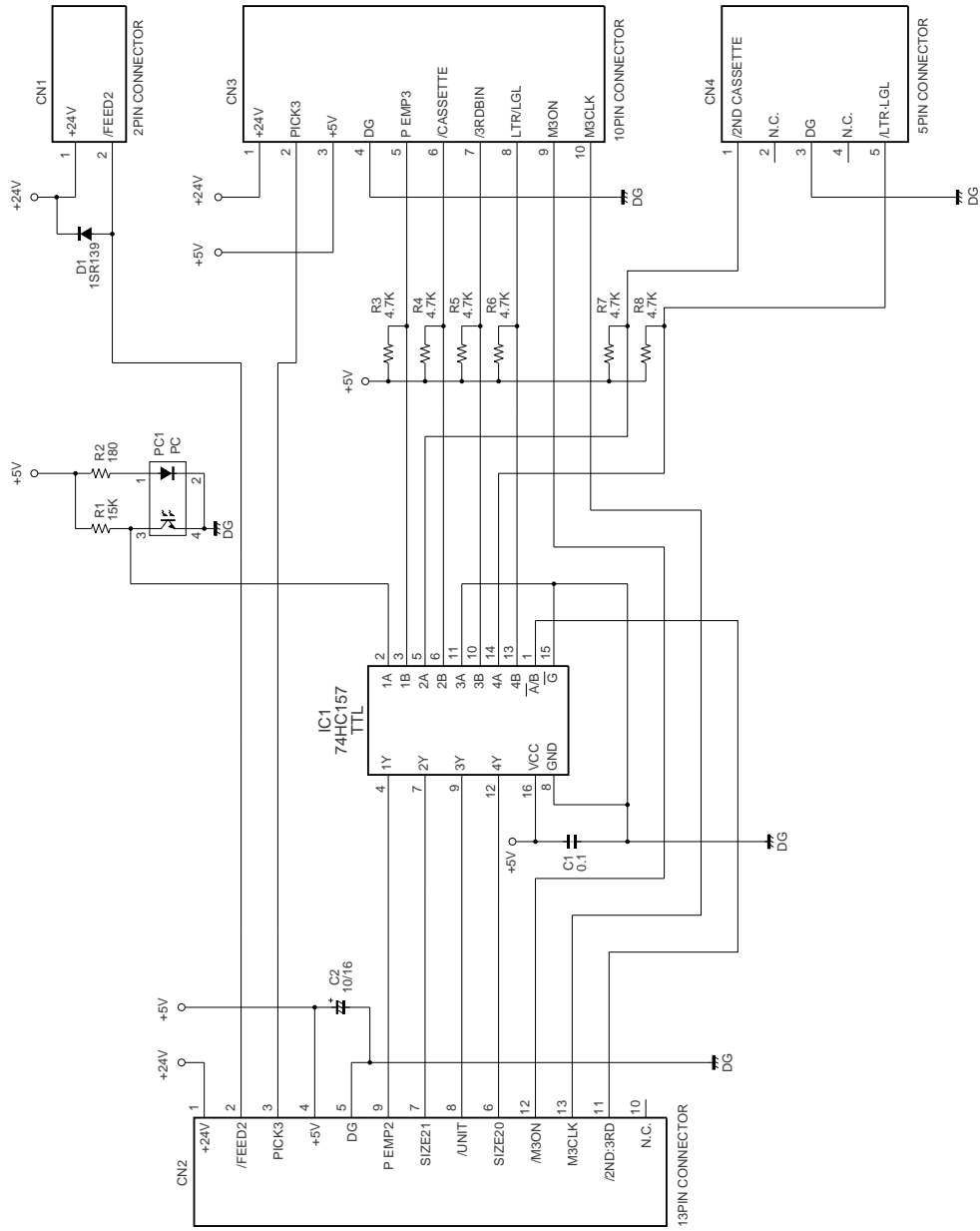

Note: Since the parts of this PWB cannot be supplied, change it as a unit.

2nd. cassette PWB parts layout

Note: Since the parts of this PWB cannot be supplied, change it as a unit.

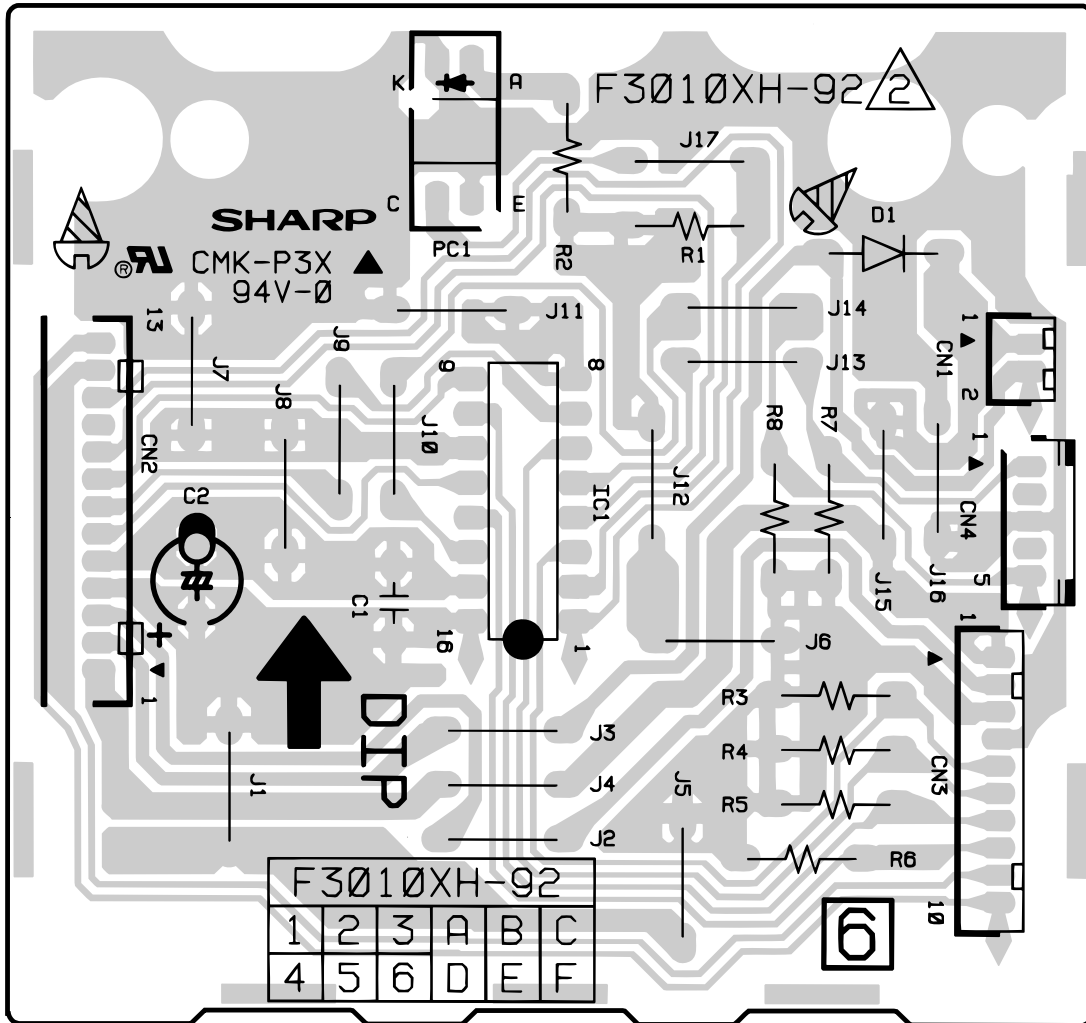

[9] Memory PWB circuit

1/3

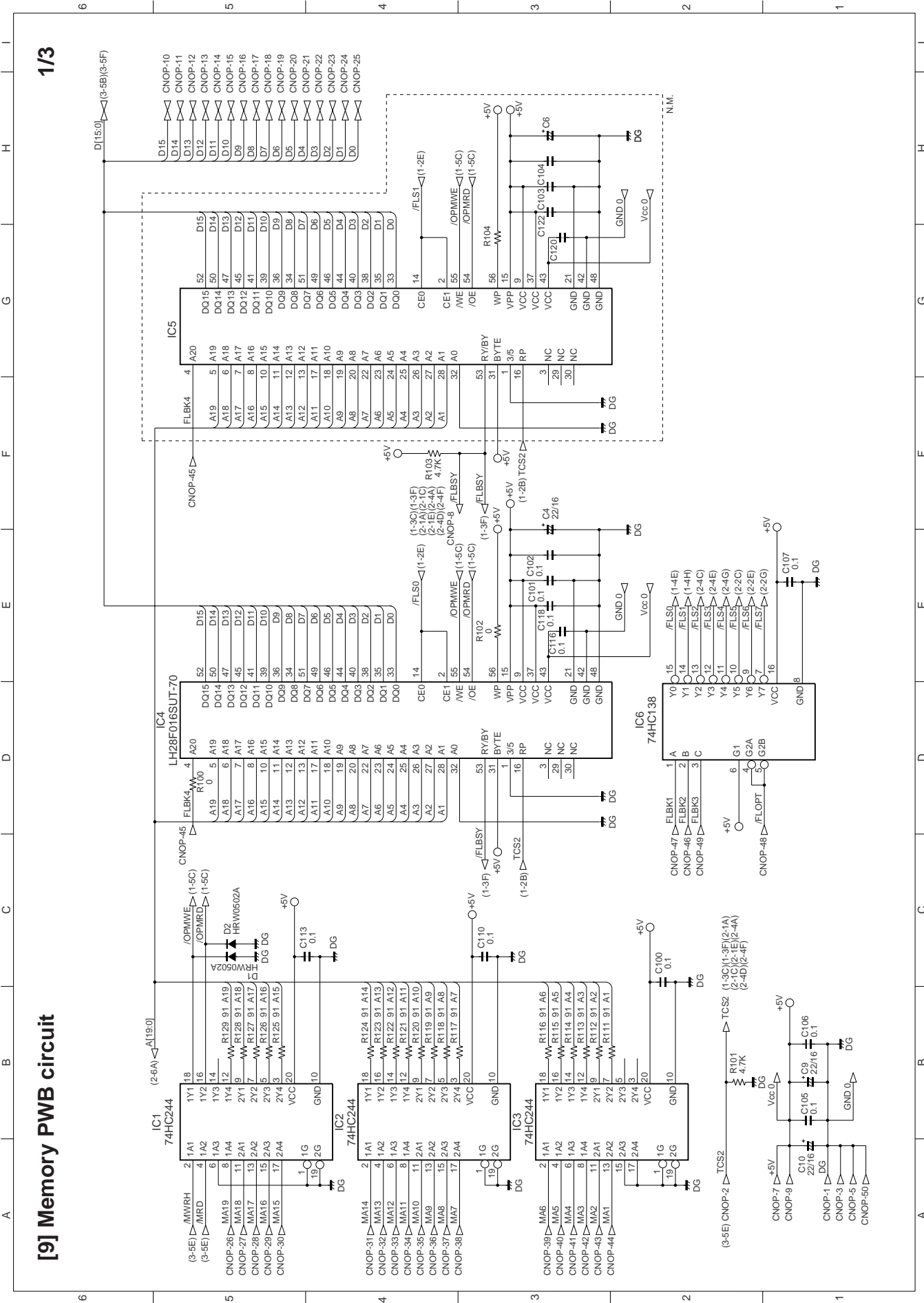

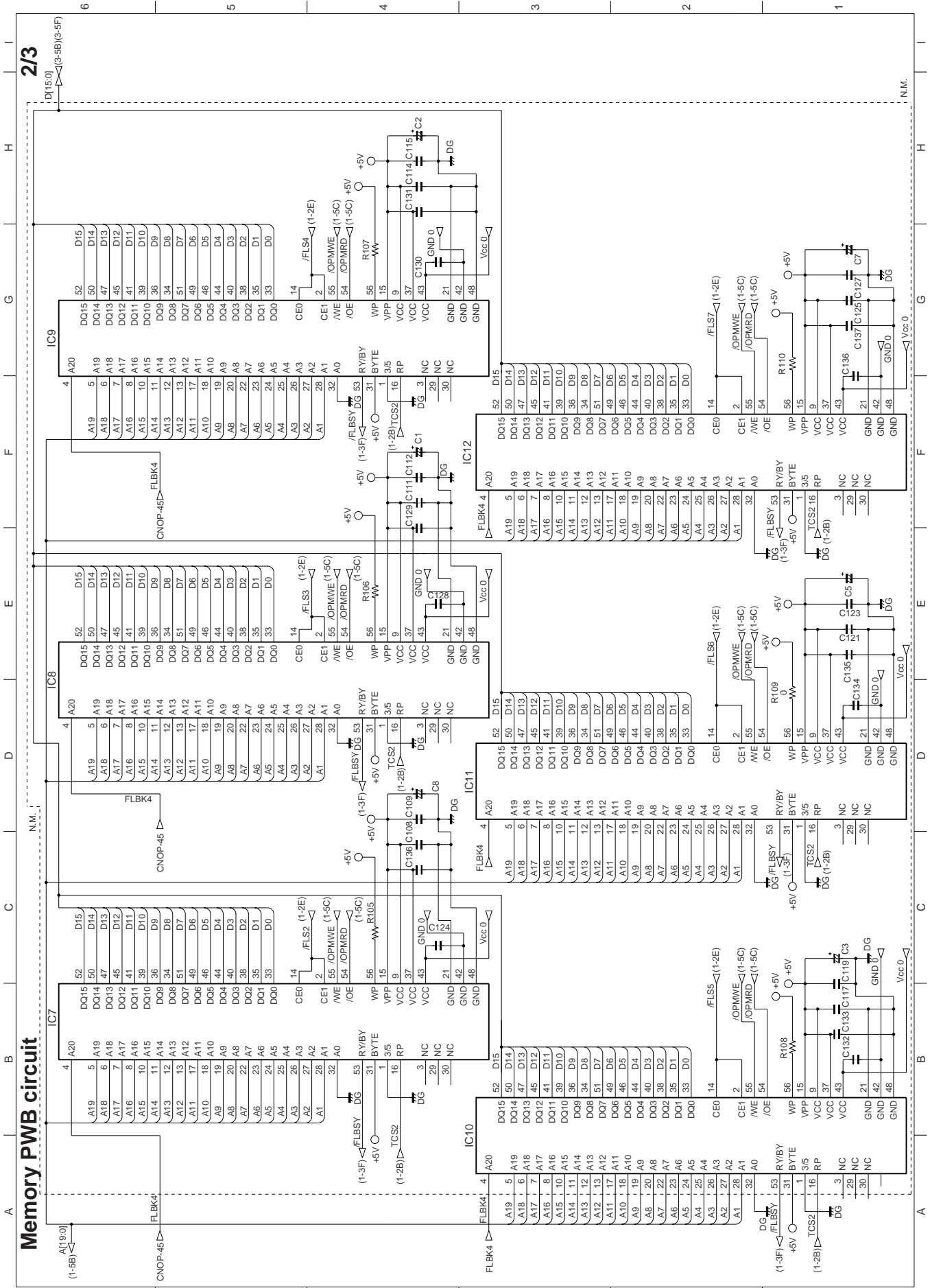

Memory PWB circuit

3/3

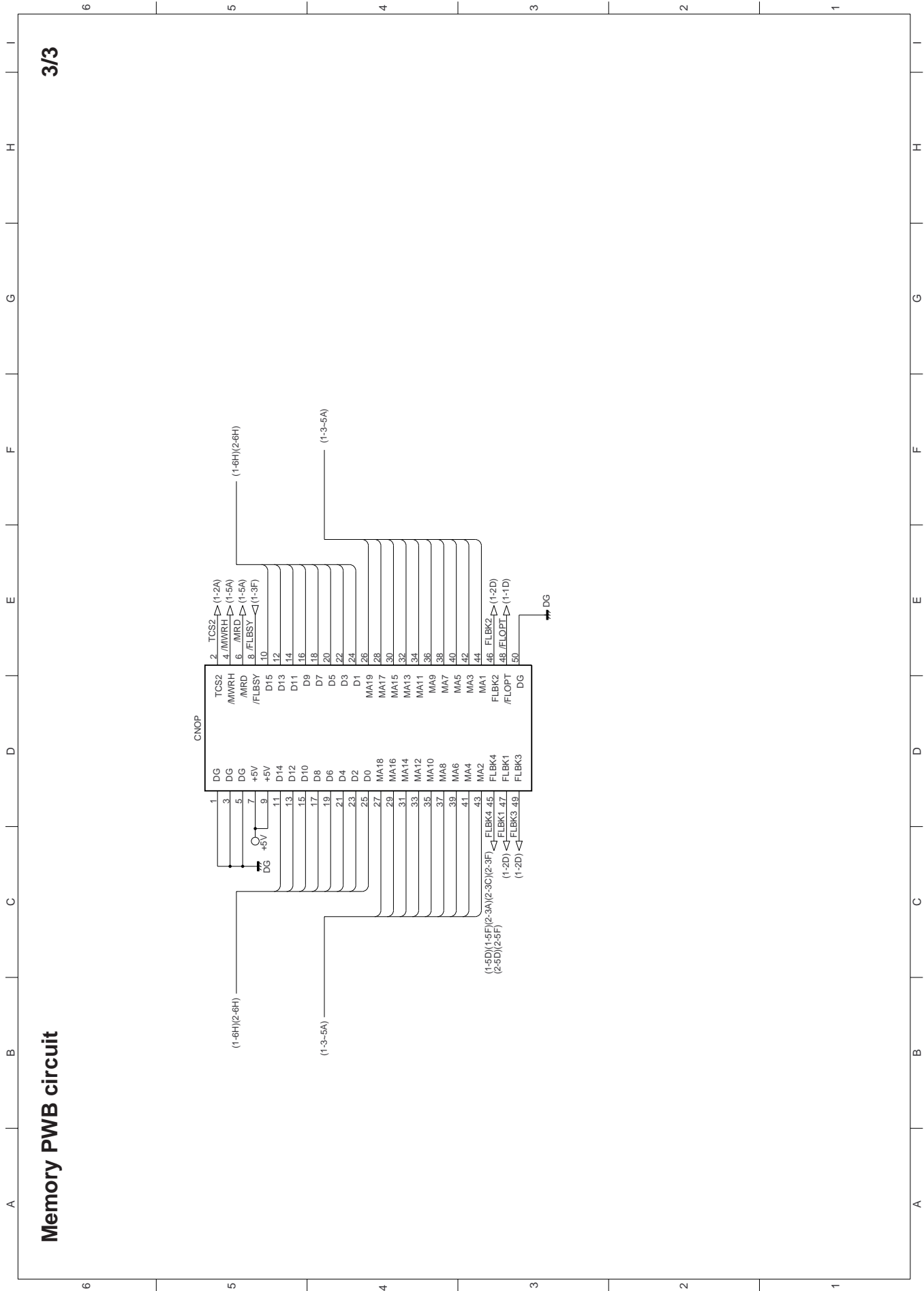

Memory PWB parts layout (Top side)

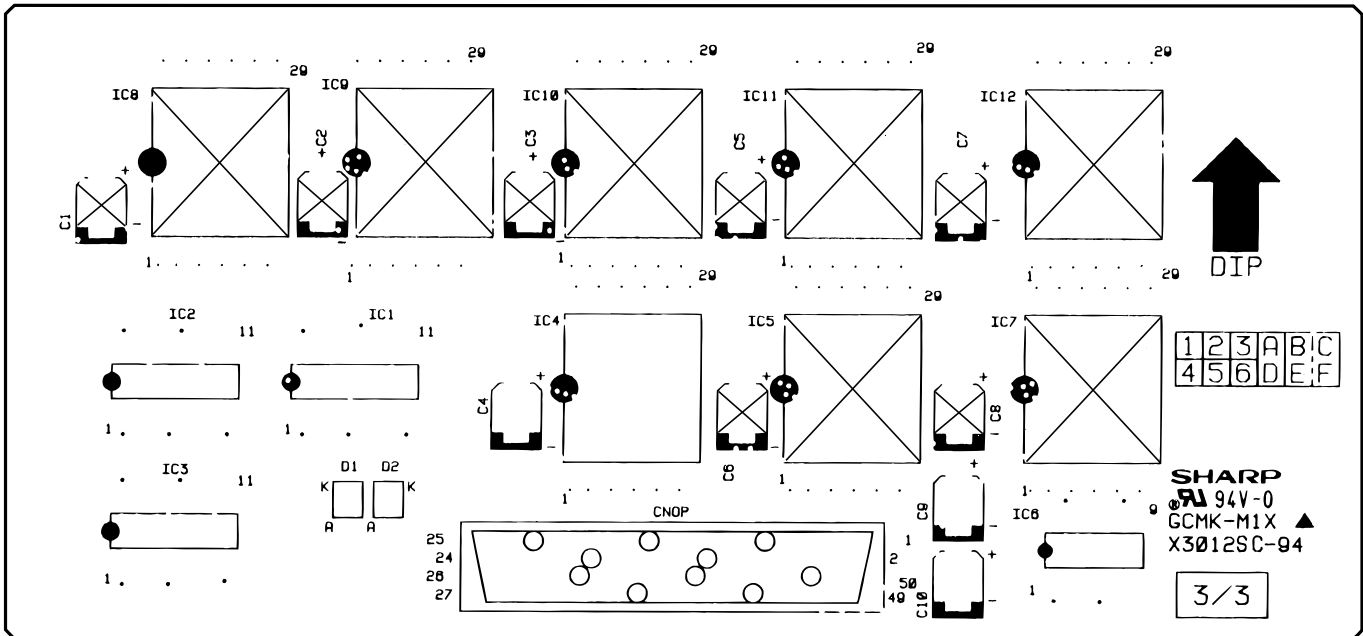

Memory PWB parts layout (Bottom side)

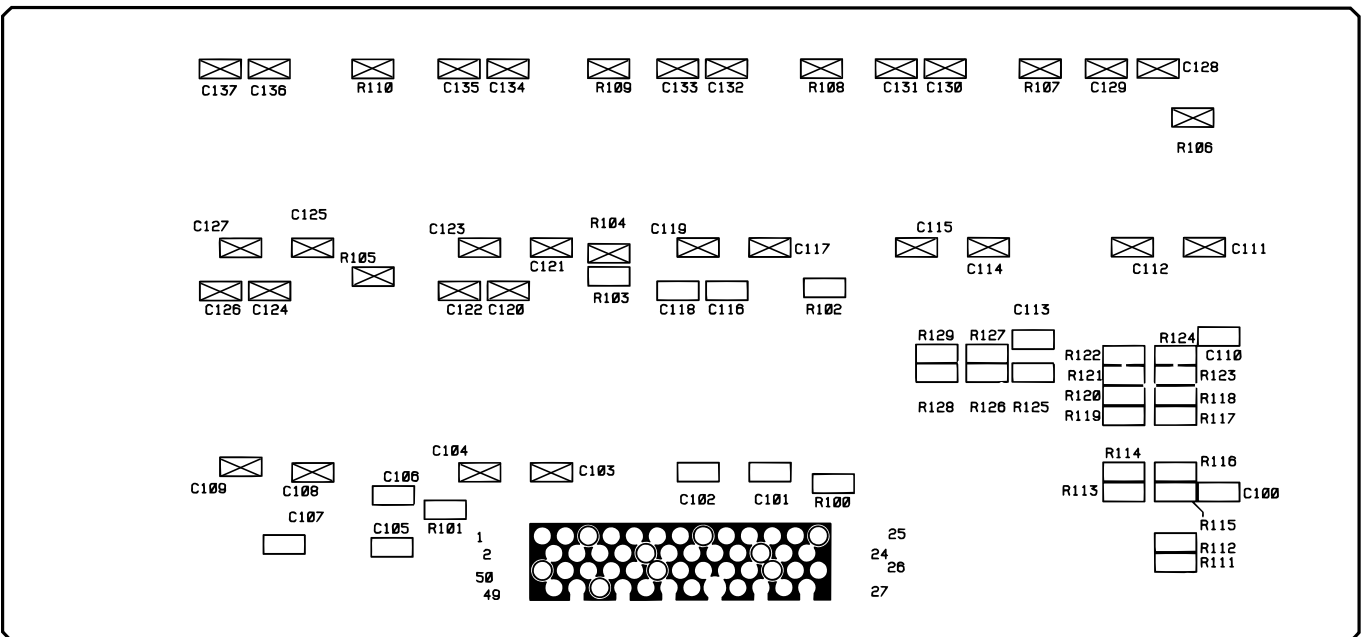

SHARP PARTS GUIDE

MODEL FO-5700

CONTENTS

- | | | | |
|----|---------------------------|----|--------------------------------|
| 1 | Exterior, etc. (1) | 13 | 2nd. cassette (2) |
| 2 | Exterior, etc. (2) | 14 | Packing material & Accessories |
| 3 | Exterior, etc. (3) | 15 | Control PWB unit |
| 4 | Operation panel unit | 16 | Liu PWB unit |
| 5 | Document guide upper unit | 17 | Printer PWB unit |
| 6 | Drive unit | 18 | Power supply PWB unit |
| 7 | Scanner frame unit | 19 | Operation panel PWB unit |
| 8 | Frames | 20 | High voltage PWB unit |
| 9 | Paper take up section | 21 | Toner empty PWB unit |
| 10 | Fusing unit | 22 | 2nd. cassette PWB unit |
| 11 | Drive/Transfer section | 23 | Memory PWB unit |
| 12 | 2nd. cassette (1) | ■ | Index |

Because parts marked with "△" is indispensable for the machine safety maintenance and operation, it must be replaced with the parts specified in the product specification.

[1] Exterior, etc. (1)

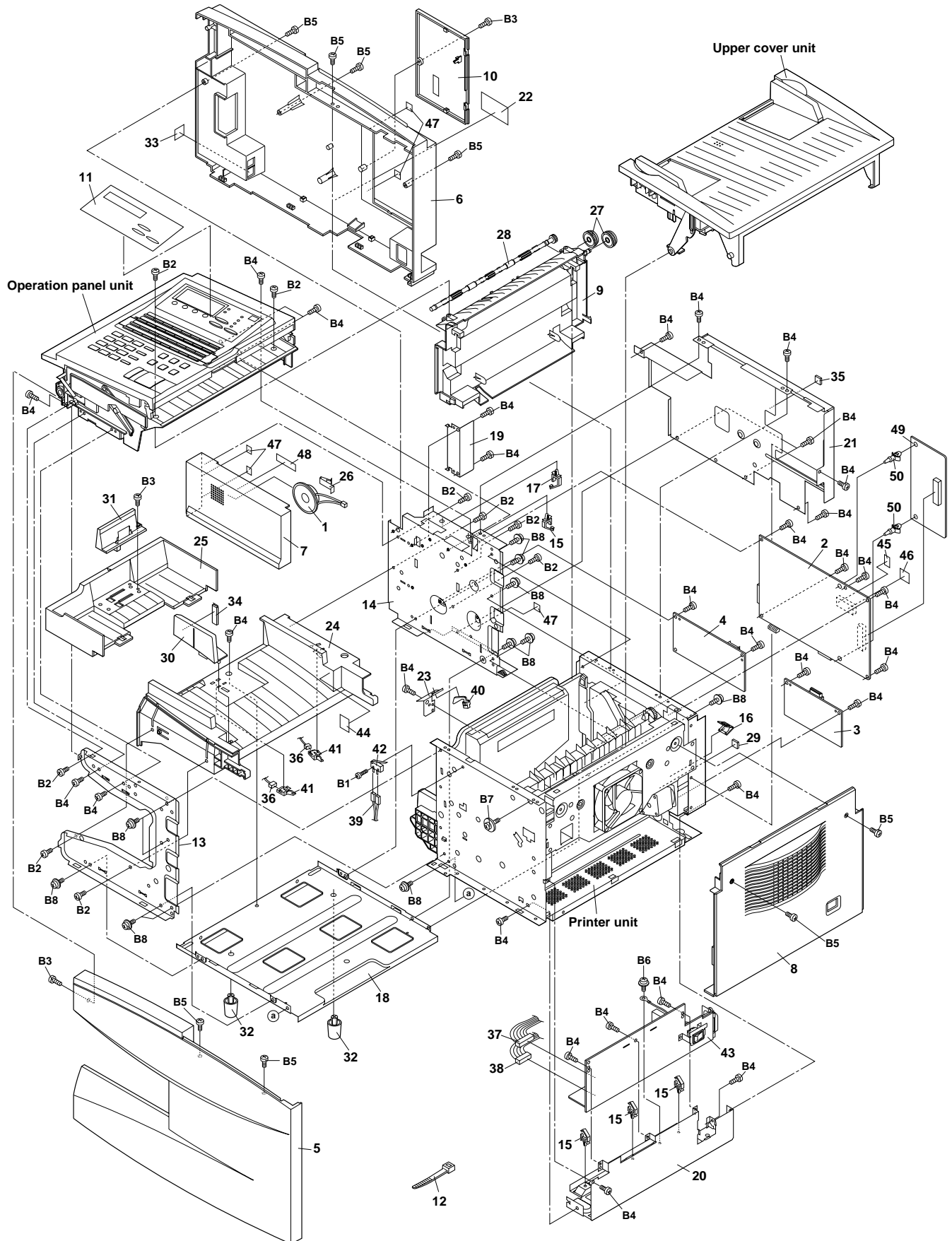

NO.	PARTS CODE	PRICE RANK	NEW MARK	PART RANK	DESCRIPTION
[1] Exterior etc.(1)					
1	CCNW-4955XH01	AG		C	Speaker ass'y
2	DCEKC489MXHZZ	CL	N	E	Control PWB unit(Within ROM)
3	DCEKC470BXH01	BR		E	Printer PWB unit
4	DCEKL471BXH01	AZ		E	LIU PWB unit
5	GCABA2327XH5B	AP	N	D	Front cabinet
6	GCABB2328XHSA	AU		D	Rear cabinet
7	GCABC2329XHSA	AG		D	Inner front cabinet
8	GCABD2330XHSA	AL		D	Right cabinet
9	GCABE2331XHSA	AK		C	Left cabinet
10	GCOVA2408XHSA	AH		D	PWB cover
11	HPNLC2399XHSA	AH	N	C	Decoration panel
12	LBNDJ2006XHZZ	AA		C	Band(100mm)
13	LFRM-2202XHZZ	AP		C	Left front frame
14	LFRM-2203XHZZ	AQ		C	Left rear frame
15	LHLDW2158SCZZ	AC		C	Wire holder
16	LHLDW2182SCZZ	AC		C	Edge holder
17	LHLDW2183SCZZ	AD		C	Wire holder
18	LPLTM3014XHZZ	AS		C	Left bottom frame
19	LPLTM3015XHZZ	AE		C	PC I/F bracket
20	LPLTM3018XHZZ	AN		C	Power supply bracket
21	LPLTM3034XHZZ	AQ		C	Shield plate
22	TLABS328AXHZZ	AC	N	D	FDA label
23	LPLTM3037XHZZ	AD		C	PS4 bracket
24	LPLTP3016XHSA	AN		C	Paper feed tray
25	LPLTP3017XHSA	AH		C	Extension paper feed tray
26	MSPRP3055XHfJ	AD		C	Speaker holder plate spring
27	NGERH2466XHZZ	AE		C	Idler gear(32Z)
28	NROLP2420XHZZ	AM		C	Left cabinet roller
29	PCUSS2122XHZZ	AC		C	PWB cushion
30	PGIDM2542XHSA	AD		C	Tray width guide
31	PGIDM2543XHSA	AD		C	Tray back guide
32	PLEGP2071XHZZ	AE		C	Foot
33	PSHEZ3410XHZZ	AB		C	Jack sheet
34	PSPO-2001XHZZ	AD		C	Tray width sponge
35	PCUSU2126XHZZ	AC		C	Sheet
36	QCNW-4952XHZZ	AF		C	Tray size switch cable
37	QCNW-4956XHZZ	AK		C	Power supply cable
38	QCNW-4957XHZZ	AL		C	Mechanism connect power supply cable
39	QCNW-4960XHZZ	AD		C	Safety switch cable
40	QSW-M2255SCZZ	AF		C	Paper out sensor [PS4]
41	QSW-M2296XHZZ	AD		C	Tray cover sensor/Paper size sensor [PS5A,B]
42	QSW-Z2285SCZZ	AK		C	Interlock switch [S2]
△	RDENT2135XHZZ	BM		E	Power supply PWB unit
44	TLABH262AXHZZ	AE		D	Paper limit label 1
45	TLABN1235CCZZ	AA		D	EPROM label
46	TLABP3078SCZZ	AA		D	Shading label
47	PSHEZ3473XHZZ	AN		C	Sheet A
48	PSHEZ3474XHZZ	AF		C	Sheet B
49	DCEKM473BXH01	BR		E	Memory PWB
50	LSTY-0057AFZZ	AC		C	Spacer
B1	XBBSD23P08000	AA		C	Screw(2.3x8)
B2	XEBSD30P10000	AA		C	Screw(3x10)
B3	XEBSE30P10000	AA		C	Screw(3x10)
B4	XHBSD30P06000	AA		C	Screw(3x6)
B5	XHBSE30P10000	AA		C	Screw(3x10)
B6	XBPSN40P06K00	AA		C	Screw(4x6)
B7	LX-BZ2205XHZZ	AC		C	Screw(3x8)
B8	LX-BZ2241XHZZ	AC		C	Screw(3x6)

[2] Exterior, etc. (2)

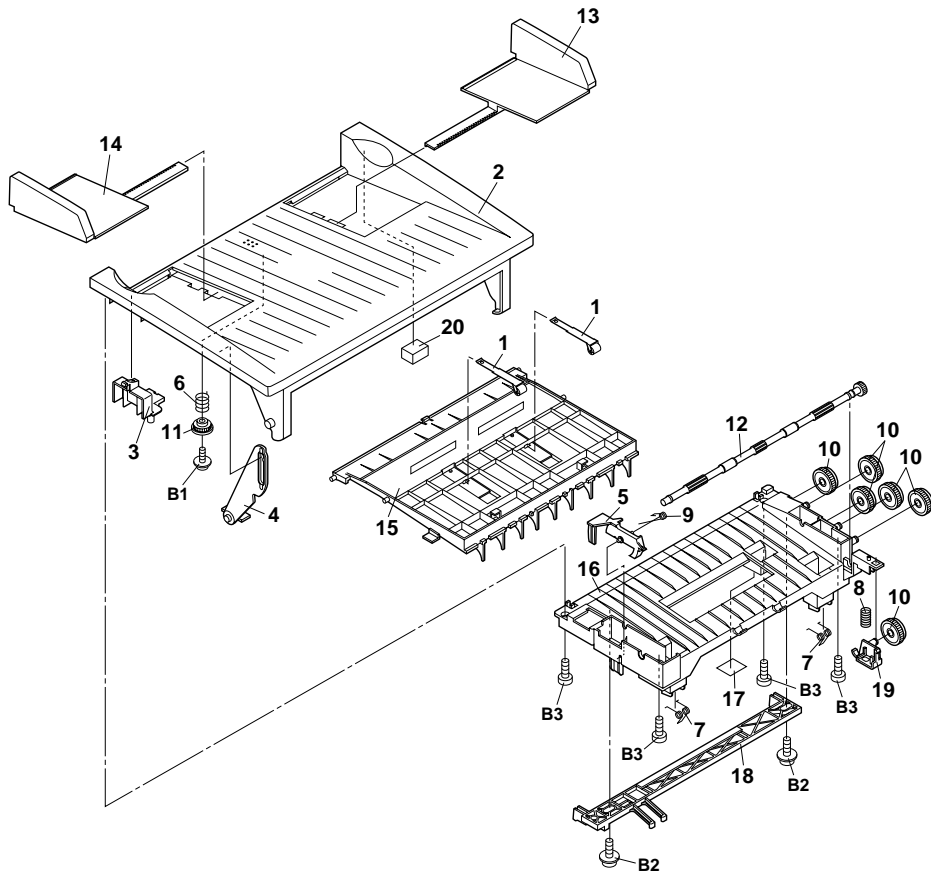

[3] Exterior, etc. (3)

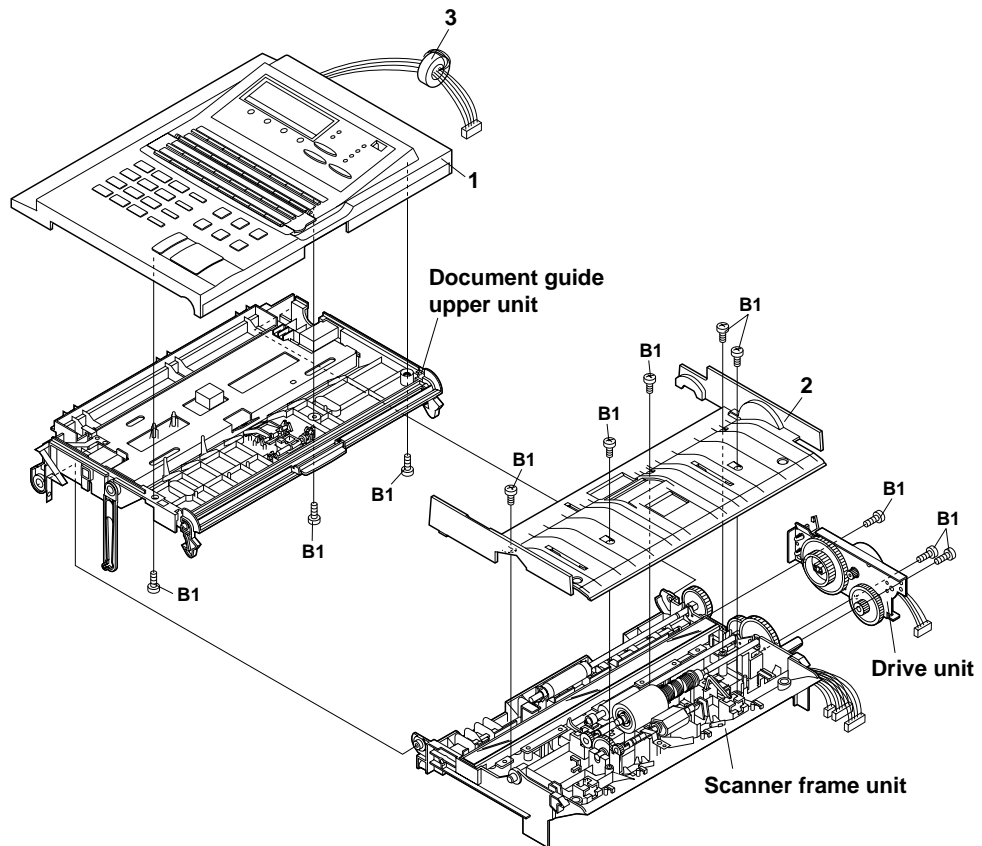

NO.	PARTS CODE	PRICE RANK	NEW MARK	PART RANK	DESCRIPTION
[2] Exterior etc.(2)					
1	CROLP2320XH01	AZ		C	Pinch roller ass'y
2	GCOVA2405XHSA	AK		C	Upper cover
3	JBTN-2255XHSA	AD		C	Upper cover lock button
4	LPLTM3019XHZZ	AD		C	Upper cover stopper
5	MLEVP2305XHZZ	AD		C	DRUM detect lever
6	MSPRC3149XHZZ	AB		C	Hopper spring
7	MSPRC3090XHZZ	AH		C	Press spring
8	MSPRC3100XHZZ	AF		C	Gear bracket spring
9	MSPRD3091XHZZ	AF		C	DRUM detect lever spring
10	NGERH2466XHZZ	AE		C	Idler gear(32Z)
11	NGERP2318XHZZ	AD		C	Pinion gear
12	NROLP2421XHZZ	AM		C	Upper cover roller
13	PGIDM2544XHSA	AE		C	Hopper guide,right
14	PGIDM2545XHSA	AC		C	Hopper guide,left
15	PGIDM2546XHZZ	AH		C	Paper exit guide upper
16	PGIDM2547XHZZ	AK		C	Upper cover guide under
17	PSHEZ3455XHZZ	AF		C	Reflection sheet
18	PTME-2060XHZZ	AF		C	Upper cover lock nail
19	LPLTM3036XHZZ	AH		C	Upper cover gear bracket
20	PCUSS2127XHZZ	AC		C	Upper cover cushion
B1	LX-BZ2138XHZZ	AB		C	Screw(3x8)
B2	LX-BZ2205XHZZ	AC		C	Screw(3x8)
B3	XEBSD30P10000	AA		C	Screw(3x10)
[3] Exterior etc.(3)					
1	CCASP2107XH51	BF		E	Operation panel unit
2	PGIDM2541XHSA	AK		C	Document guide under
3	RCORF2125XHZZ	AE		B	Core
B1	XEBSD30P10000	AA		C	Screw(3x10)

[4] Operation panel unit

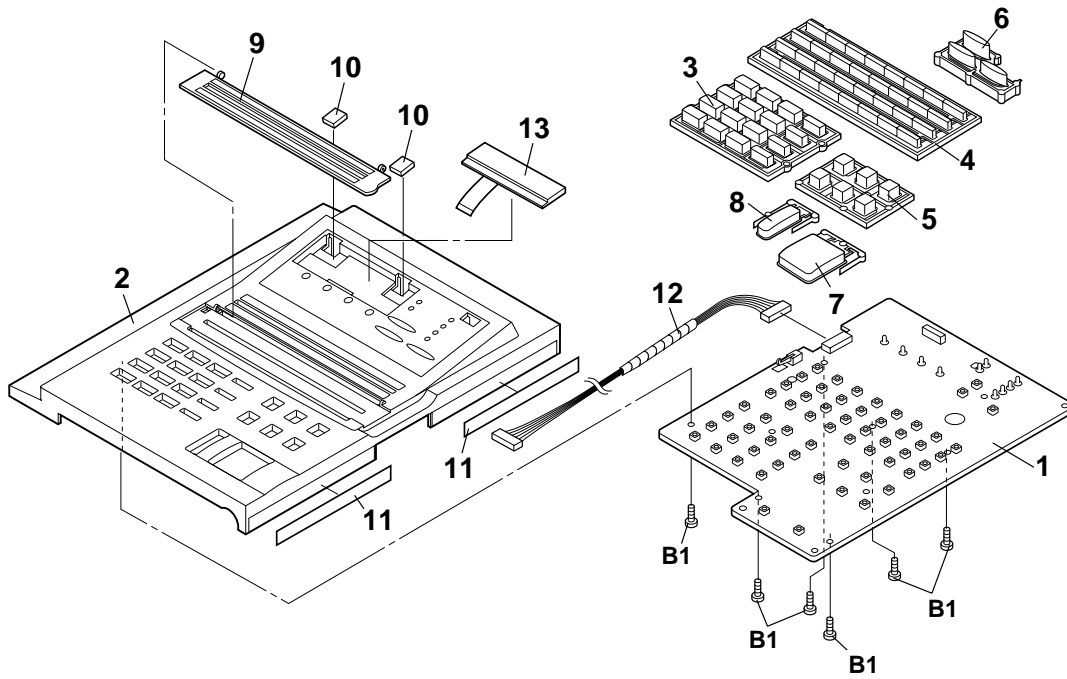

[5] Document guide upper unit

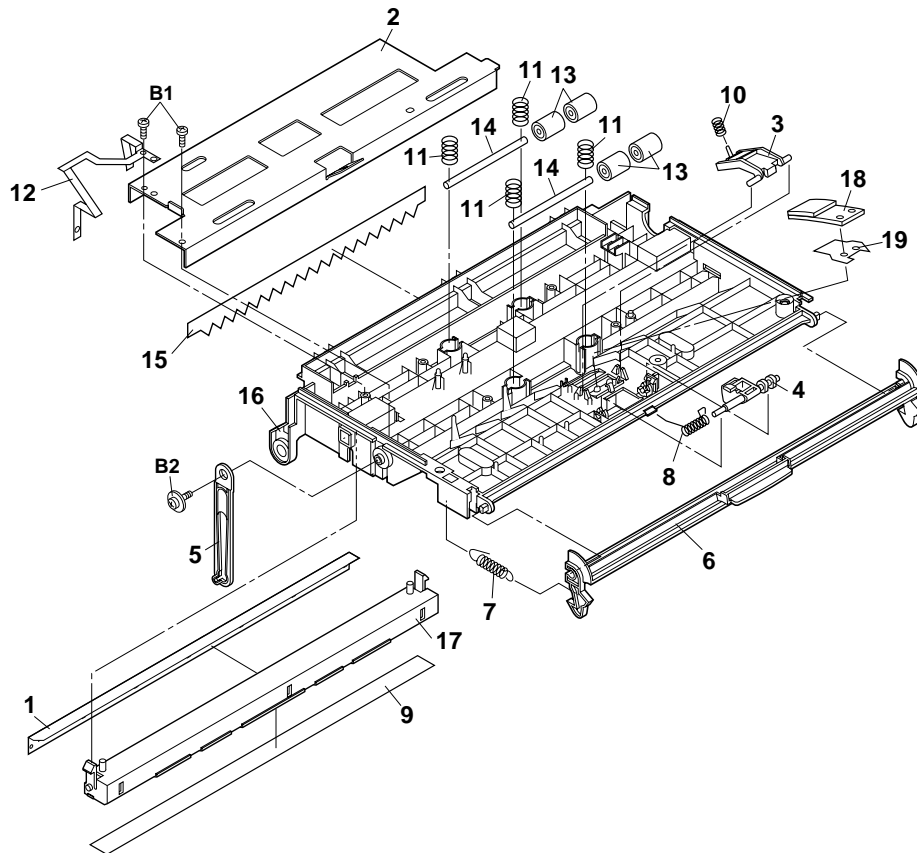

[6] Drive unit

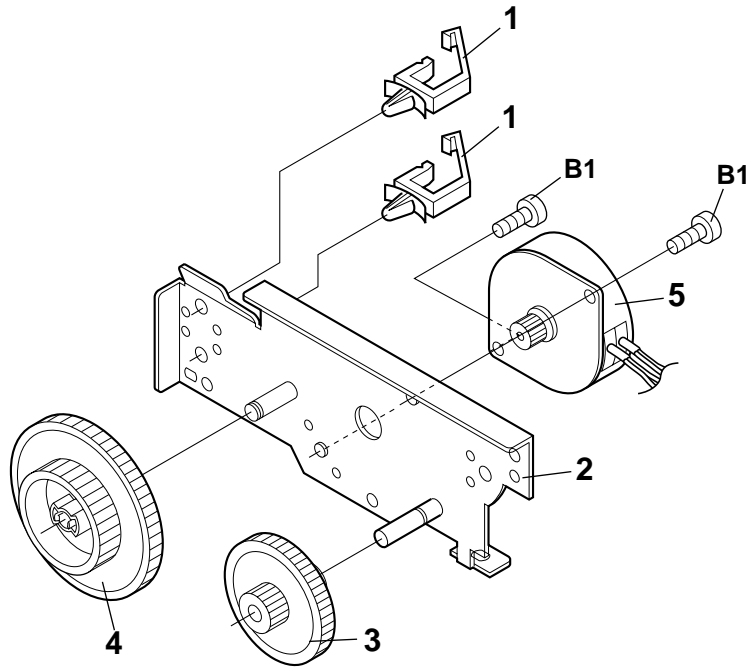

[7] Scanner frame unit

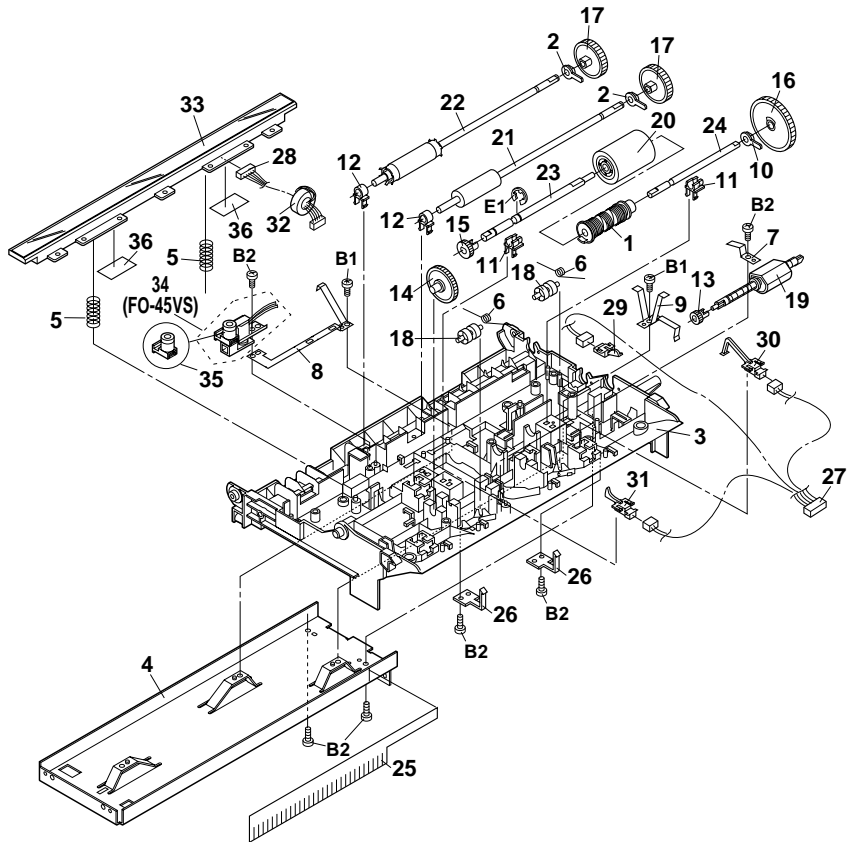

[8] Frames

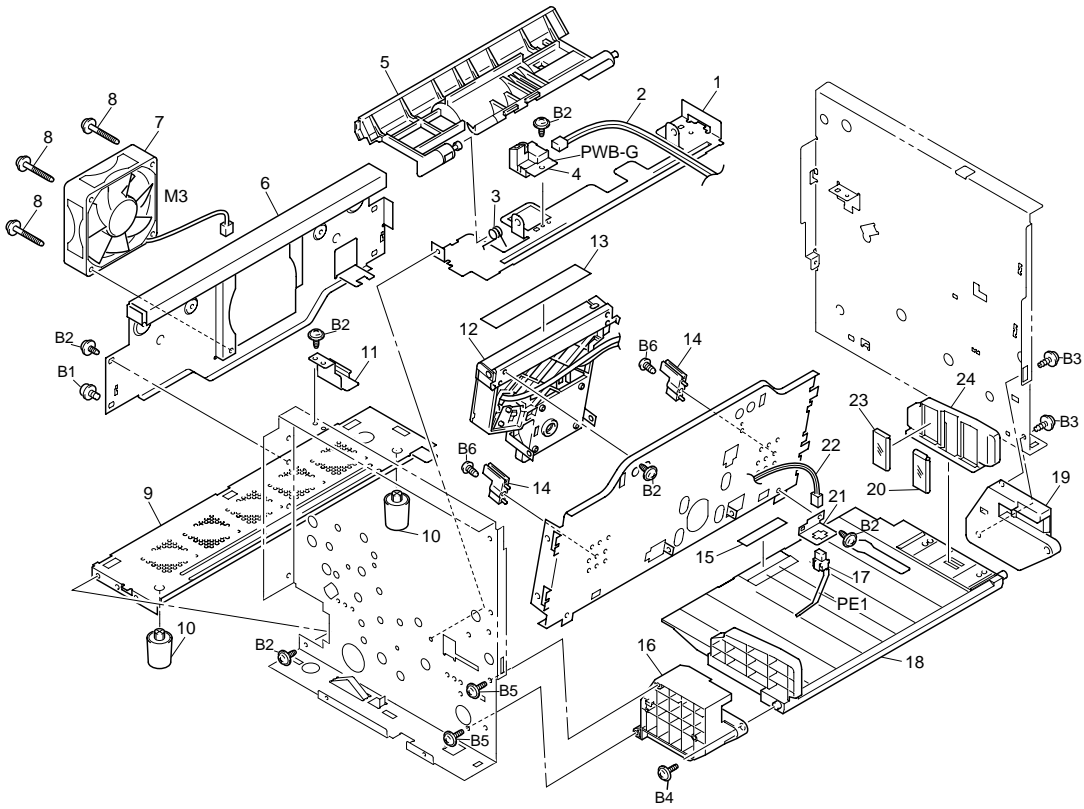

[9] Paper take up section

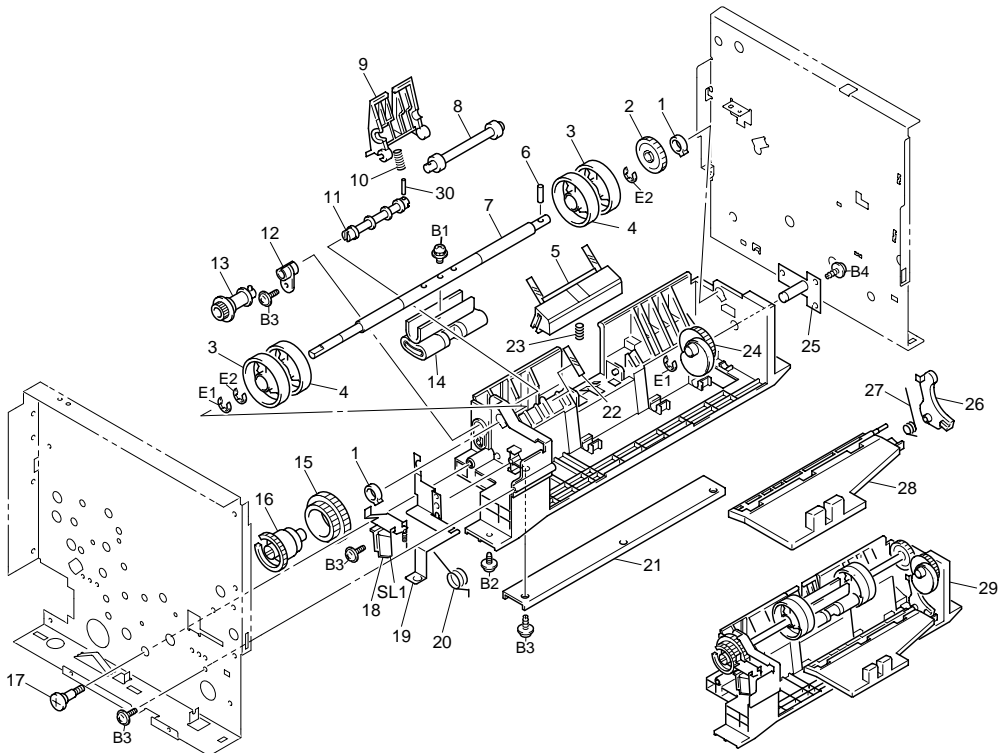

NO.	PARTS CODE	PRICE RANK	NEW MARK	PART RANK	DESCRIPTION
[8] Frames					
1	0KW4122207102	AM		C	Reinforce plate
2	0KW4122681702	AN		C	Wire harness assy
3	0KW4109302202	AC		C	Torsion spring
4	0KW4122010202	BD		E	Toner empty PWB unit [PWB-G]
5	0KW4109302005	AL		C	Guide
6	0KW4122207801	BB		C	Bracket
7	0KW4122610101	BP		B	Fan motor [M3]
8	0KW0993204501	AC		C	Screw,special
9	0KW4122207902	AQ		C	Reinforce plate
10	0KW4122235001	AF		C	Rubber foot
11	0KW4122207001	AD		C	Bracket
12	0KW4109053103	BY		E	Print head unit
13	0KW4109202401	AF		D	Label
14	0KW4109202102	AD		C	Holder
15	0KW4109301302	AD		C	Sheet
16	0KW4122206901	AG		C	Holder
17	0KW4122630401	AL		B	Paper empty sensor [PE1]
18	0KW4122360502	AQ		C	Lifting plate
19	0KW4122206801	AQ		C	Holder
20	0KW4122340401	AD		C	Guide
21	0KW4122207601	AD		C	Bracket
22	0KW4122681401	AL		C	Wire harness assy
23	0KW4122340501	AD		C	Guide
24	0KW4122340201	AF		C	Regulating plate
B1	0KW9646030613	AB		C	Screw
B2	0KW9735030613	AB		C	Tapping screw
B3	0KW9739030813	AB		C	Tapping screw
B4	0KW9739030613	AB		C	Tapping screw
B5	0KW9739030813	AB		C	Tapping screw
B6	0KW9743030813	AB		C	Tapping screw
[9] Paper take-up section					
1	0KW0972300901	AF		C	Bushing
2	0KW4122360701	AF		C	Gear(28T)
3	0KW4122305601	AH		C	Roll
4	0KW4122305501	AL		C	Roll
5	0KW4110075101	AT		C	Separated pad
6	0KW0957304001	AE		C	Pin
7	0KW4122362902	AQ		C	Shaft
8	0KW4122300201	BK		C	Roller
9	0KW4109350203	AH		C	Holder
10	0KW4110301801	AC		C	Pressure spring
11	0KW4109303301	AF		C	Joint
12	0KW4109301514	AD		C	Bushing
13	0KW4109301412	AD		C	Gear(18T)
14	0KW4122300101	AU		C	Roller
15	0KW4109303413	AF		C	Gear(36/54T)
16	0KW4109301003	AF		C	Gear(36T)
17	0KW4109305101	AD		C	Shoulder screw
18	0KW4122620101	BC		B	Paper take up solenoid [SL1]
19	0KW4122365001	AG		C	Earth ground
20	0KW4122361902	AC		C	Torsion spring
21	0KW4109305201	AG		C	Plate
22	0KW4110350301	AC		C	Polyester film
23	0KW4109304103	AC		C	Pressure spring
24	0KW4122355602	AG		C	Cam gear(28T)
25	0KW4122020101	AG		C	Bracket
26	0KW4122364201	AG		C	Arm
27	0KW4122361602	AD		C	Torsion spring
28	0KW4122364301	AR		C	Lever
29	0KW4122033102	BT		E	Paper take-up unit
30	0KW9751301050	BG		C	Pin
B1	0KW9646030813	AB		C	Screw
B2	0KW9735030613	AB		C	Tapping screw
B3	0KW9739030813	AB		C	Tapping screw
B4	0KW9739030613	AB		C	Tapping screw
E1	0KW9721050001	AU		C	Retaining ring
E2	0KW9721090001	BB		C	Retaining ring

[10] Fusing unit

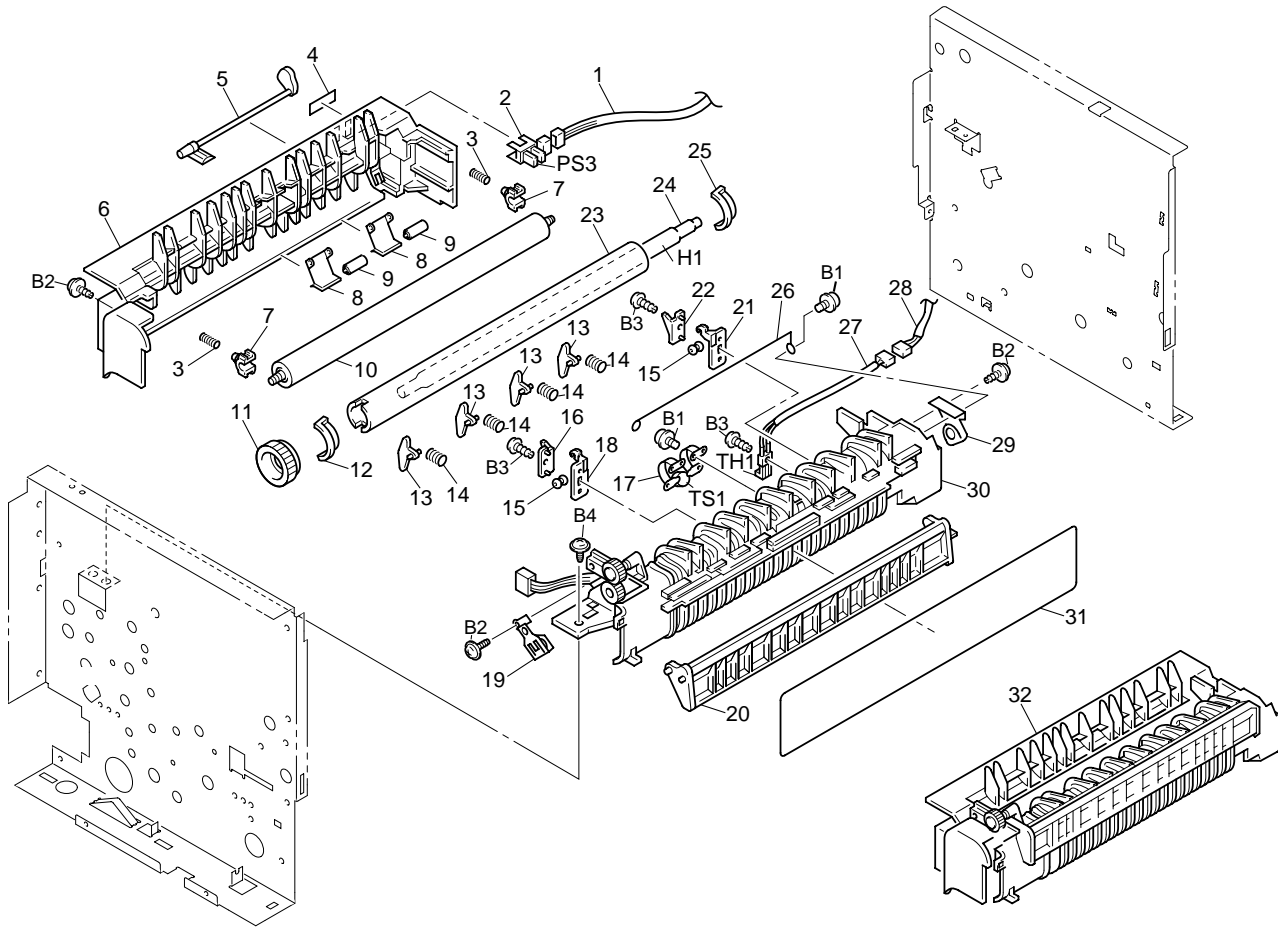

[11] Drive/Transfer section

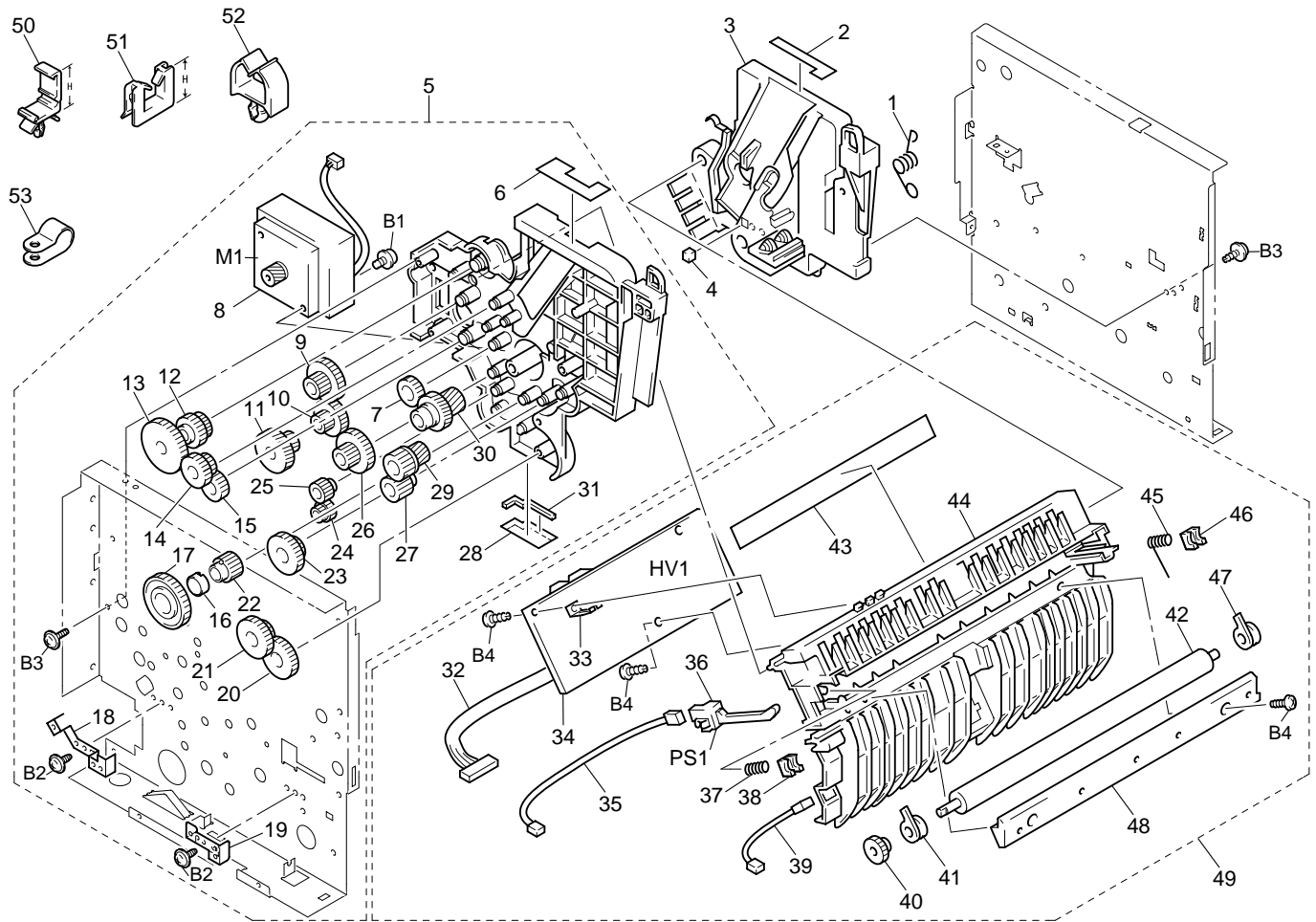

[12] 2nd. cassette (1)

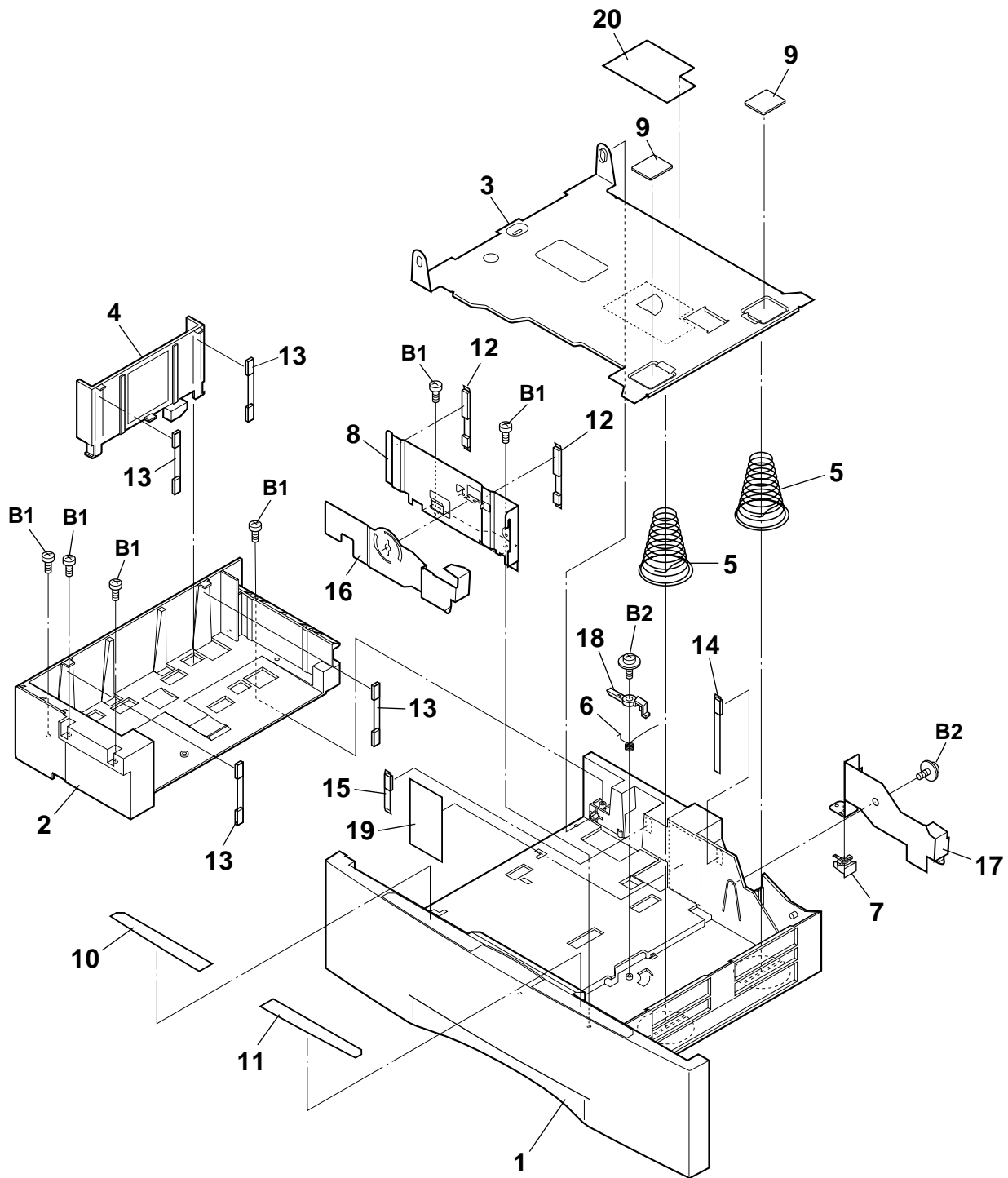

[13] 2nd. cassette (2)

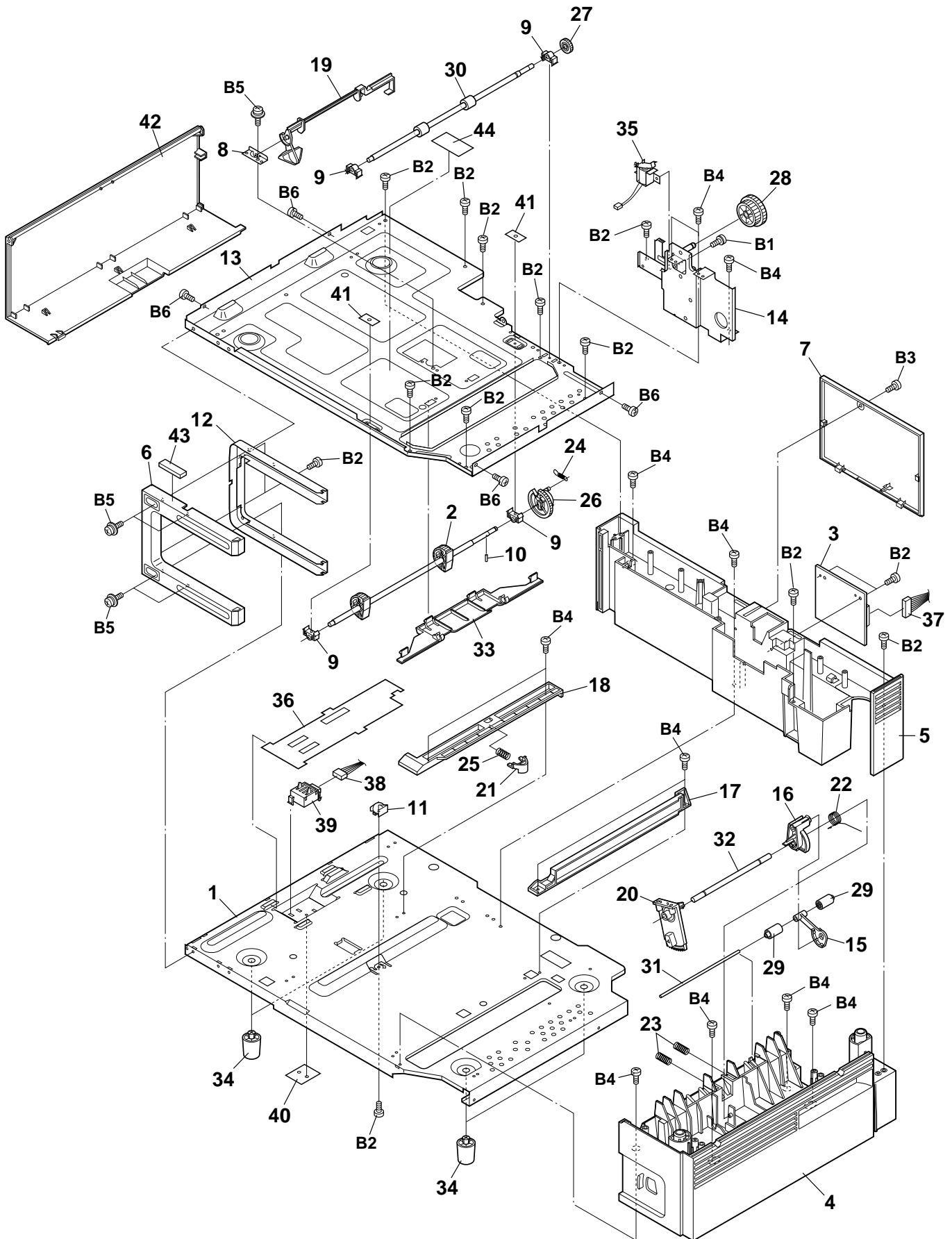

NO.	PARTS CODE	PRICE RANK	NEW MARK	PART RANK	DESCRIPTION
[13] 2nd.cassette(2)					
1	LPLTM3024XHZZ	AX		C	2nd. bottom plate
2	CROLR2423XH01	AV		C	2nd. PU roller
3	DCEKZ472BXH01	AT	N	E	2nd. cassette PWB unit
4	GCABG2333XHSA	AQ		C	2nd. right cabinet
5	GCABH2334XHSA	AN		C	2nd. rear cabinet
6	GCOVA2407XHSA	AH		C	Slide frame cover
7	GCOVA2408XHSA	AH		C	PWB cover
8	LANGF2825XHZZ	AF		C	Lever bracket
9	LBSHP2109XHZZ	AF		C	2nd. drive bearing
10	LPINS2032XHZZ	AF		C	Roller pin
11	PCAPH2032XHZZ	AC		C	Separate nail rear cap
12	LPLTM3025XHZZ	AS		C	Slide frame plate
13	LPLTM3027XHZZ	AW		C	2nd. top plate
14	LPLTM3028XHZZ	AN		C	2nd. Drive system plate
15	LPLTP3023XHZZ	AF		C	2nd. lever joint 1
16	LPLTP3044XHZZ	AF		C	2nd. lever joint 2
17	LRALP2023XHZZ	AD		C	2nd. cassette rail right
18	LRALP2024XHZZ	AD		C	2nd. cassette rail left
19	MLEVP2308XHZZ	AD		C	2nd. paper sensor lever
20	MLEVP2309XHZZ	AE		C	2nd. release lever
21	MLOK-2008XHZZ	AC		C	Cassette lock piece
22	MSPRD3093XHZZ	AG	N	C	2nd. release lever spring
23	MSPRC3095XHZZ	AD		C	2nd. pinch roller spring
24	MSPRC3096XHZZ	AC		C	2nd. clutch spring
25	MSPRC3097XHZZ	AD		C	Cassette lock spring
26	NGERH2469XHZZ	AC		C	Paper feed clutch gear
27	NGERH2470XHZZ	AC		C	Paper drive gear
28	NGERH2471XHZZ	AE		C	Docking gear
29	NROLP2334XHZA	AC		C	Pinch roller
30	NROLR2422XHZZ	AN		C	2nd. drive roller
31	NSFTZ2309XHZZ	AC		C	2nd. pinch roller shaft
32	NSFTZ2312XHZZ	AC		C	2nd. release shaft
33	PGIDM2552XHZZ	AM		C	2nd. guide upper
34	PLEGP2071XHZZ	AE		C	Foot
35	PMAGE2056XHZZ	AN		C	Solenoid
36	PSHEZ3437XHZZ	AF		C	Cassette sensor cover
37	QCNW-4962XHZZ	AF		C	Cassette connect cable
38	QCNW-4964XHZZ	AF		C	2nd. paper size cable
39	QSW-Z2286XHZZ	AH		C	Cassette size sensor
40	PSHEZ3478XHZZ	AB	N	C	Sensor sheet
41	PSHEZ3477XHZZ	AB	N	C	Bearing sheet
42	GCOVA2406XHSA	AF		C	Left cover
43	PSPAZ2253XHZZ	AD	N	C	Cabinet spacer 2
44	TLABS373BXHZZ	AC	N	D	UL label
B1	XBPSD30P06K00	AA		C	Screw(3x6)
B2	XEBSD30P10000	AA		C	Screw(3x10)
B3	XEBSE30P10000	AA		C	Screw(3x10)
B4	XHBSD30P06000	AA		C	Screw(3x6)
B5	LX-BZ2240XHZZ	AB		C	Screw(3x6)
B6	XHBSE30P06000	AA		C	Screw(3x6)

[14] Packing material & Accessories

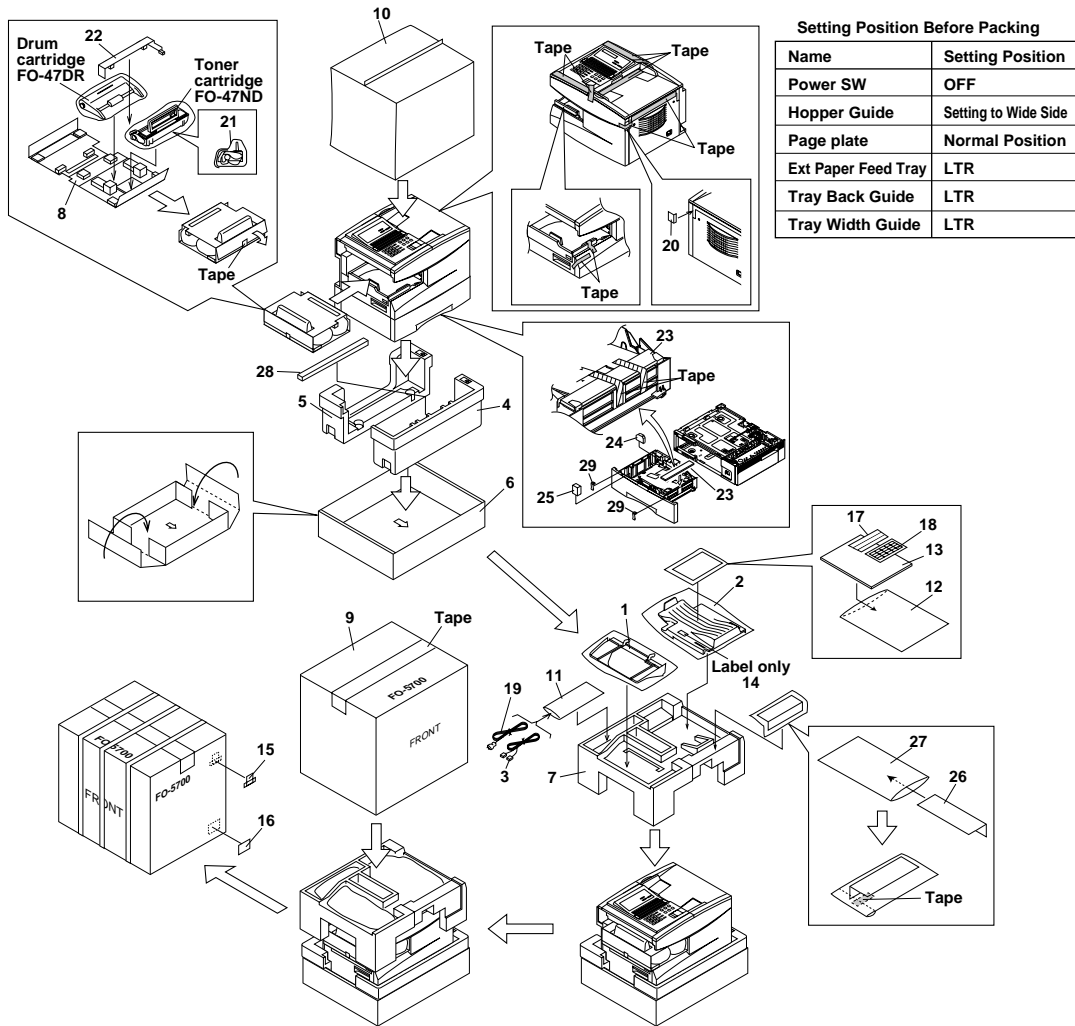

NO.	PARTS CODE	PRICE RANK	NEW MARK	PART RANK	DESCRIPTION
[14] Packing material & Accessories					
1	CPLTP2803XHC3	AV		C	Document tray ass'y
2	CPLTP3009XHC1	AU		C	Paper stock tray with label ass'y
3	QCNW-4786XHGY	AL	N	C	Line cable
4	SPAKA301BXXH01	AK	N	D	Packing add.,bottom front
5	SPAKA301BXXH02	AK	N	D	Packing add.,bottom back
6	SPAKA130BXXHZZ	AH		C	Bottom tray
7	SPAKA505AXHZZ	AF		D	Packing add.,top
8	SPAKA506AXHZZ	AP		D	Packing add
9	SPAKC515AXHZZ	AR	N	D	Packing case,top(Made in Thailand)
	SPAKC515ASCZZ	AR	N	D	Packing case,top(Made in Japan)
10	SPAKP261BXXHZZ	AM		D	Vinyl cover
11	SSAKA1430QCZZ	AB		D	Vinyl bag
12	SSAKA2003XHZZ	AA		D	Vinyl bag(240x360mm)
13	TINSE3926XHZA	AQ		D	Operation manual
14	TLABH4813XHSA	AE		D	Tray caution label
15	TLABM2506XHZZ	AB		D	TH No. label
16	TLABM4804XHZZ	AA		D	Code 39 label
17	TLABP3937XHZZ	AD		D	Paper size label
18	TLABZ3935XHZZ	AF	N	D	Rapid key labels
19	QACCD7618QCZZ	AQ		C	AC cord
20	SPAKA006AXHZZ	AC		C	Protection sheet
21	SPAKA241BXXHZZ	AH		C	Air sheet
22	SPAKA166BXXHZZ	AH		C	Protection Sheet
23	SPAKA146BXXHZZ	AH		D	Cassette protection
24	SPAKA229BXXHZZ	AE		C	Cassette protection pad A
25	SPAKA230BXXHZZ	AE		C	Cassette protection pad B
26	GCOVA2406XHSA	AF		C	Left cover
27	SSAKA2342QCZZ	AA		C	Vinyl bag
28	SPAKA416BXXHZZ		N	D	Protect add
29	PSHEZ3264XHZZ	AH	N	C	Cabinet spacer

NO.	PARTS CODE	PRICE RANK	NEW MARK	PART RANK	DESCRIPTION	
[15] Control PWB unit						
1	UBATL2071XHZZ	AL		B	Battery	[BT1]
2	VCEAGA1HW107M	AA		C	Capacitor(50WV 100μF)	[C2]
3	VCEAGA1CW476M	AB		C	Capacitor(16WV 47μF)	[C3]
4	VCEAGA1CW476M	AB		C	Capacitor(16WV 47μF)	[C4]
5	VCEAGA1HW475M	AA		C	Capacitor(50WV 4.7μF)	[C7]
6	VCEAGA1HW105M	AB		C	Capacitor(50WV 1μF)	[C8]
7	VCEAGA1CW476M	AB		C	Capacitor(16WV 47μF)	[C9]
8	VCEAEA1CW336M	AB		C	Capacitor(16WV 33μF)	[C10]
9	VCEAEA1CW336M	AB		C	Capacitor(16WV 33μF)	[C11]
10	VCEAEA1VW476M	AH		C	Capacitor(35WV 47μF)	[C12]
11	VCEAEA1CW336M	AB		C	Capacitor(16WV 33μF)	[C13]
12	VCEAGA1EW106M	AA		C	Capacitor(25WV 10μF)	[C14]
13	VCEAGA1EW106M	AA		C	Capacitor(25WV 10μF)	[C15]
14	VCEAGA1EW106M	AA		C	Capacitor(25WV 10μF)	[C16]
15	VCEAGA1EW106M	AA		C	Capacitor(25WV 10μF)	[C17]
16	VCEAGA1EW106M	AA		C	Capacitor(25WV 10μF)	[C18]
17	VCEAGA1EW476M	AA		C	Capacitor(25WV 47μF)	[C19]
18	VCEAGA1CW476M	AB		C	Capacitor(16WV 47μF)	[C20]
19	VCKYTV1EF104Z	AA		C	Capacitor(25WV 0.1μF)	[C100]
20	VCKYTV1EF104Z	AA		C	Capacitor(25WV 0.1μF)	[C103]
21	VCKYTV1EF104Z	AA		C	Capacitor(25WV 0.1μF)	[C104]
22	VCKYTV1CF105Z	AB		C	Capacitor(16WV 1μF)	[C106]
23	VCKYTV1EF104Z	AA		C	Capacitor(25WV 0.1μF)	[C107]
24	VCKYTV1HF104Z	AA		C	Capacitor(50WV 0.1μF)	[C108]
25	VCKYTV1EF104Z	AA		C	Capacitor(25WV 0.1μF)	[C109]
26	VCKYTV1EF104Z	AA		C	Capacitor(25WV 0.1μF)	[C111]
27	VCKYTV1EF104Z	AA		C	Capacitor(25WV 0.1μF)	[C112]
28	VCKYTV1HB222K	AA		C	Capacitor(50WV 2200PF)	[C113]
29	VCKYTV1HB222K	AA		C	Capacitor(50WV 2200PF)	[C114]
30	VCKYTV1EF104Z	AA		C	Capacitor(25WV 0.1μF)	[C115]
31	VCKYTV1EF104Z	AA		C	Capacitor(25WV 0.1μF)	[C116]
32	VCKYTV1EF104Z	AA		C	Capacitor(25WV 0.1μF)	[C117]
33	VCCCTV1HH180J	AA		C	Capacitor(50WV 18PF)	[C118]
34	VCKYTV1EF104Z	AA		C	Capacitor(25WV 0.1μF)	[C119]
35	VCKYTV1EF104Z	AA		C	Capacitor(25WV 0.1μF)	[C120]
36	VCKYTV1EF104Z	AA		C	Capacitor(25WV 0.1μF)	[C121]
37	VCKYTV1EF104Z	AA		C	Capacitor(25WV 0.1μF)	[C122]
38	VCKYTV1HF103Z	AA		C	Capacitor(50WV 0.01μF)	[C123]
39	VCKYTV1EF104Z	AA		C	Capacitor(25WV 0.1μF)	[C124]
40	VCKYTV1HF103Z	AA		C	Capacitor(50WV 0.01μF)	[C125]
41	VCCCTV1HH150J	AA		C	Capacitor(50WV 15PF)	[C126]
42	VCKYTV1EF104Z	AA		C	Capacitor(25WV 0.1μF)	[C127]
43	VCCSTV1HL471J	AC		C	Capacitor(50WV 470PF)	[C128]
44	VCCSTV1HL331J	AA		C	Capacitor(50WV 330PF)	[C130]
45	VCCSTV1HL471J	AC		C	Capacitor(50WV 470PF)	[C131]
46	VCCSTV1HL331J	AA		C	Capacitor(50WV 330PF)	[C132]
47	VCKYTV1EF104Z	AA		C	Capacitor(25WV 0.1μF)	[C133]
48	VCKYTV1EF104Z	AA		C	Capacitor(25WV 0.1μF)	[C134]
49	VCKYTV1EF104Z	AA		C	Capacitor(25WV 0.1μF)	[C135]
50	VCKYTV1EF104Z	AA		C	Capacitor(25WV 0.1μF)	[C137]
51	VCKYTV1EF104Z	AA		C	Capacitor(25WV 0.1μF)	[C138]
52	VCCCTV1HH120J	AA		C	Capacitor(50WV 12PF)	[C139]
53	VCKYTV1EF104Z	AA		C	Capacitor(25WV 0.1μF)	[C142]
54	VCKYTV1HB222K	AA		C	Capacitor(50WV 2200PF)	[C143]
55	VCKYTV1HB222K	AA		C	Capacitor(50WV 2200PF)	[C144]
56	VCKYTV1HB102K	AA		C	Capacitor(50WV 1000PF)	[C146]
57	VCCSTV1HL331J	AA		C	Capacitor(50WV 330PF)	[C147]
58	VCKYTV1EF104Z	AA		C	Capacitor(25WV 0.1μF)	[C148]
59	VCKYTV1EF104Z	AA		C	Capacitor(25WV 0.1μF)	[C149]
60	VRS-TS2AD000J	AA		C	Resistor(1/10W 0Ω ±5%)	[C151]
61	VCKYTV1EF104Z	AA		C	Capacitor(25WV 0.1μF)	[C153]
62	VCKYTV1HB222K	AA		C	Capacitor(50WV 2200PF)	[C154]
63	VCKYTV1EF104Z	AA		C	Capacitor(25WV 0.1μF)	[C155]
64	VCCCTV1HH150J	AA		C	Capacitor(50WV 15PF)	[C156]
65	VCKYTV1HB222K	AA		C	Capacitor(50WV 2200PF)	[C157]
66	VCKYTV1CF105Z	AB		C	Capacitor(16WV 1μF)	[C158]
67	VCKYTV1CF105Z	AB		C	Capacitor(16WV 1μF)	[C160]
68	VCCCTV1HH300J	AA		C	Capacitor(50WV 30PF)	[C161]
69	VCCSTV1HL102J	AA		C	Capacitor(50WV 1000PF)	[C162]
70	VCCCTV1HH101J	AA		C	Capacitor(50WV 100PF)	[C163]
71	VCKYTV1EF104Z	AA		C	Capacitor(25WV 0.1μF)	[C164]
72	VCKYTV1CF105Z	AB		C	Capacitor(16WV 1μF)	[C166]
73	VCKYTV1EF104Z	AA		C	Capacitor(25WV 0.1μF)	[C167]
74	VCKYTV1EF104Z	AA		C	Capacitor(25WV 0.1μF)	[C168]
75	VCCCTV1HH300J	AA		C	Capacitor(50WV 30PF)	[C169]
76	VCKYTV1EF104Z	AA		C	Capacitor(25WV 0.1μF)	[C170]
77	VCKYTV1EF104Z	AA		C	Capacitor(25WV 0.1μF)	[C171]
78	VCKYTV1EF104Z	AA		C	Capacitor(25WV 0.1μF)	[C174]
79	VCKYTV1HB222K	AA		C	Capacitor(50WV 2200PF)	[C177]
80	VCCCTV1HH120J	AA		C	Capacitor(50WV 12PF)	[C178]

NO.	PARTS CODE	PRICE RANK	NEW MARK	PART RANK	DESCRIPTION	
[15] Control PWB unit						
81	VCKYTV1EF104Z	AA		C	Capacitor(25WV 0.1μF)	[C179]
82	VCKYTV1EF104Z	AA		C	Capacitor(25WV 0.1μF)	[C180]
83	VCKYTV1EF104Z	AA		C	Capacitor(25WV 0.1μF)	[C181]
84	VCKYTV1EF104Z	AA		C	Capacitor(25WV 0.1μF)	[C182]
85	VCKYTV1HB102K	AA		C	Capacitor(50WV 1000PF)	[C183]
86	VCKYTV1EF104Z	AA		C	Capacitor(25WV 0.1μF)	[C189]
87	VCKYTV1EF104Z	AA		C	Capacitor(25WV 0.1μF)	[C190]
88	VCKYTV1EF104Z	AA		C	Capacitor(25WV 0.1μF)	[C192]
89	VCKYTV1EF104Z	AA		C	Capacitor(25WV 0.1μF)	[C196]
90	VCKYTV1HB222K	AA		C	Capacitor(50WV 2200PF)	[C197]
91	VCKYTV1HB222K	AA		C	Capacitor(50WV 2200PF)	[C198]
92	VCKYTV1HB103K	AB		C	Capacitor(50WV 0.01μF)	[C200]
93	VCKYTV1EF104Z	AA		C	Capacitor(25WV 0.1μF)	[C202]
94	VCKYTV1HB222K	AA		C	Capacitor(50WV 2200PF)	[C203]
95	VCKYTV1EF104Z	AA		C	Capacitor(25WV 0.1μF)	[C205]
96	VCKYTV1EF104Z	AA		C	Capacitor(25WV 0.1μF)	[C206]
97	VCKYTV1EF104Z	AA		C	Capacitor(25WV 0.1μF)	[C207]
98	VCKYTV1EF104Z	AA		C	Capacitor(25WV 0.1μF)	[C208]
99	VCKYTV1EF104Z	AA		C	Capacitor(25WV 0.1μF)	[C211]
100	VCKYTV1EF104Z	AA		C	Capacitor(25WV 0.1μF)	[C212]
101	VCKYTV1EF104Z	AA		C	Capacitor(25WV 0.1μF)	[C221]
102	VCKYTV1EB104K	AA		C	Capacitor(25WV 0.1μF)	[C222]
103	VCKYTV1HB472K	AA		C	Capacitor(50WV 4700PF)	[C223]
104	VCKYTV1EF104Z	AA		C	Capacitor(25WV 0.1μF)	[C226]
105	VCKYTV1HB222K	AA		C	Capacitor(50WV 2200PF)	[C227]
106	VCKYTV1EF104Z	AA		C	Capacitor(25WV 0.1μF)	[C228]
107	VCKYTV1HB222K	AA		C	Capacitor(50WV 2200PF)	[C229]
108	VCKYTV1HB222K	AA		C	Capacitor(50WV 2200PF)	[C230]
109	VCKYTV1HB222K	AA		C	Capacitor(50WV 2200PF)	[C231]
110	VCKYTV1HB222K	AA		C	Capacitor(50WV 2200PF)	[C232]
111	VCKYTV1EF104Z	AA		C	Capacitor(25WV 0.1μF)	[C233]
112	VCKYTV1EF104Z	AA		C	Capacitor(25WV 0.1μF)	[C234]
113	VCCCTV1HH270J	AC		C	Capacitor(50WV 27PF)	[C235]
114	VCCCTV1HH200J	AA		C	Capacitor(50WV 20PF)	[C236]
115	VCKYTV1EF104Z	AA		C	Capacitor(25WV 0.1μF)	[C237]
116	VCKYTV1HB222K	AA		C	Capacitor(50WV 2200PF)	[C238]
117	VCKYTV1EF104Z	AA		C	Capacitor(25WV 0.1μF)	[C239]
118	VCKYTV1EF104Z	AA		C	Capacitor(25WV 0.1μF)	[C241]
119	VCCCTV1HH100D	AA		C	Capacitor(50WV 10PF)	[C242]
120	VCCCTV1HH100D	AA		C	Capacitor(50WV 10PF)	[C243]
121	VCKYTV1EF104Z	AA		C	Capacitor(25WV 0.1μF)	[C246]
122	VCKYTV1EF104Z	AA		C	Capacitor(25WV 0.1μF)	[C247]
123	VCKYTV1EF104Z	AA		C	Capacitor(25WV 0.1μF)	[C249]
124	VCKYTV1EF104Z	AA		C	Capacitor(25WV 0.1μF)	[C250]
125	VCKYTV1EF104Z	AA		C	Capacitor(25WV 0.1μF)	[C251]
126	VCKYTV1EF104Z	AA		C	Capacitor(25WV 0.1μF)	[C252]
127	VCCSTV1HL331J	AA		C	Capacitor(50WV 330PF)	[C269]
128	VCKYTV1EB104K	AA		C	Capacitor(25WV 0.1μF)	[C270]
129	VCKYTV1EF104Z	AA		C	Capacitor(25WV 0.1μF)	[C273]
130	VCKYTV1CF105Z	AB		C	Capacitor(16WV 1μF)	[C274]
131	VCKYTV1EF104Z	AA		C	Capacitor(25WV 0.1μF)	[C275]
132	VCKYTV1EF104Z	AA		C	Capacitor(25WV 0.1μF)	[C277]
133	VCCCTV1HH120J	AA		C	Capacitor(50WV 12PF)	[C278]
134	VCCCTV1HH180J	AA		C	Capacitor(50WV 18PF)	[C279]
135	VCKYTV1HF104Z	AA		C	Capacitor(50WV 0.1μF)	[C280]
136	VCKYTV1EF104Z	AA		C	Capacitor(25WV 0.1μF)	[C401]
137	VCKYTV1EF104Z	AA		C	Capacitor(25WV 0.1μF)	[C403]
138	VCKYTV1HB222K	AA		C	Capacitor(50WV 2200PF)	[C404]
139	VCKYTV1HB222K	AA		C	Capacitor(50WV 2200PF)	[C405]
140	VCKYTV1HB222K	AA		C	Capacitor(50WV 2200PF)	[C406]
141	VCKYTV1HB222K	AA		C	Capacitor(50WV 2200PF)	[C407]
142	VCKYTV1HB222K	AA		C	Capacitor(50WV 2200PF)	[C408]
143	VCKYTV1HB222K	AA		C	Capacitor(50WV 2200PF)	[C409]
144	VCKYTV1HB222K	AA		C	Capacitor(50WV 2200PF)	[C410]
145	VCKYTV1CF105Z	AB		C	Capacitor(16WV 1μF)	[C421]
146	VCKYTV1HB102K	AA		C	Capacitor(50WV 1000PF)	[C422]
147	VCKYTV1EF104Z	AA		C	Capacitor(25WV 0.1μF)	[C426]
148	VCCCTV1HH101J	AA		C	Capacitor(50WV 100PF)	[C428]
149	VCKYTV1HB222K	AA		C	Capacitor(50WV 2200PF)	[C500]
150	VCKYTV1HB222K	AA		C	Capacitor(50WV 2200PF)	[C501]
151	VCKYTV1HB103K	AB		C	Capacitor(50WV 0.01μF)	[C502]
152	VCCCTV1HH100D	AA		C	Capacitor(50WV 10PF)	[C503]
153	VCCCTV1HH3R0C	AA	N	C	Capacitor(50WV 3PF)	[C504]
154	VCKYTV1EF104Z	AA		C	Capacitor(25WV 0.1μF)	[C505]
155	VCKYTV1EB104K	AA		C	Capacitor(25WV 0.1μF)	[C506]
156	VCKYTV1EB104K	AA		C	Capacitor(25WV 0.1μF)	[C507]
157	VCKYTV1EB104K	AA		C	Capacitor(25WV 0.1μF)	[C508]
158	VCKYTV1EB104K	AA		C	Capacitor(25WV 0.1μF)	[C509]
159	VCCSTV1HL181J	AD		C	Capacitor(50WV 180PF)	[C510]
160	VCKYTV1EB104K	AA		C	Capacitor(25WV 0.1μF)	[C511]

NO.	PARTS CODE	PRICE RANK	NEW MARK	PART RANK	DESCRIPTION	
[15] Control PWB unit						
161	VCKYTV1EF104Z	AA		C	Capacitor(25WV 0.1μF)	[C512]
162	VCKYTV1CF225Z	AD		C	Capacitor(16WV 2.2μF)	[C513]
163	VCKYTV1EF104Z	AA		C	Capacitor(25WV 0.1μF)	[C514]
164	VCKYTV1EF104Z	AA		C	Capacitor(25WV 0.1μF)	[C515]
165	VCKYTV1EF104Z	AA		C	Capacitor(25WV 0.1μF)	[C516]
166	VCKYTV1CF105Z	AB		C	Capacitor(16WV 1μF)	[C517]
167	VCKYTV1EF104Z	AA		C	Capacitor(25WV 0.1μF)	[C518]
168	VCKYTV1EF104Z	AA		C	Capacitor(25WV 0.1μF)	[C519]
169	VCKYTV1EF104Z	AA		C	Capacitor(25WV 0.1μF)	[C520]
170	VCKYTV1HF104Z	AA		C	Capacitor(50WV 0.1μF)	[C521]
171	VCKYTV1EF104Z	AA		C	Capacitor(25WV 0.1μF)	[C522]
172	VCKYTV1EF104Z	AA		C	Capacitor(25WV 0.1μF)	[C523]
173	VCKYTV1EF104Z	AA		C	Capacitor(25WV 0.1μF)	[C524]
174	VCKYTV1HB331K	AA	N	C	Capacitor(50WV 330PF)	[C525]
175	VCKYTV1HB221K	AA		C	Capacitor(50WV 220PF)	[C526]
176	VCCCTV1HH101J	AA		C	Capacitor(50WV 100PF)	[C527]
177	VCKYTV1HB102K	AA		C	Capacitor(50WV 1000PF)	[C528]
178	VCKYTV1EF104Z	AA		C	Capacitor(25WV 0.1μF)	[C529]
179	VCKYTV1EB104K	AA		C	Capacitor(25WV 0.1μF)	[C530]
180	VCKYTV1CF225Z	AD		C	Capacitor(16WV 2.2μF)	[C532]
181	VCCCTV1HH470J	AA		C	Capacitor(50WV 47PF)	[C533]
182	VCCCTV1HH470J	AA		C	Capacitor(50WV 47PF)	[C534]
183	QCNCM7014SC1J	AC		C	Connector(10pin)	[CNCIS]
184	QCNCM2499SC0I	AE		C	Connector(9pin)	[CNLIU]
185	QCNCM2589SC5J	AL		C	Connector(50pin)	[CNOP]
186	QCNCM2525SC4J	AK		C	Connector(40pin)	[CNPCIF]
187	QCNCM2482SC2D	AB		C	Connector(24pin)	[CNPIN]
188	QCNCM2525SC3J	AH		C	Connector(30pin)	[CNPRT]
189	QCNCM7014SC1B	AD		C	Connector(12pin)	[CNPW]
190	QCNCM7014SC0H	AB		C	Connector(8pin)	[CNSEN]
191	QCNCM2401SC0B	AA		C	Connector(2pin)	[CNSP]
192	QCNCM7014SC0B	AD		C	Connector(2pin)	[CNSTP]
193	QCNCM7014SC0D	AB		C	Connector(4pin)	[CNTXM]
194	VHDSR104///-1	AF		B	Diode(SR104)	[D1]
195	VHDSR104///-1	AF		B	Diode(SR104)	[D2]
196	VHDSR104///-1	AF		B	Diode(SR104)	[D3]
197	VHDSR104///-1	AF		B	Diode(SR104)	[D4]
198	VHDDAP202U/-1	AB		B	Diode(DAP202U)	[D5]
199	VHDDA204K///-1	AC		B	Diode(DA204K)	[D100]
200	VHD1SS355///-1	AB		B	Diode(1SS355)	[D101]
201	VHDHRW0502A-1	AD		B	Diode(HRW0502A)	[D102]
202	VHDHRW0502A-1	AD		B	Diode(HRW0502A)	[D103]
203	VHDHRW0502A-1	AD		B	Diode(HRW0502A)	[D104]
204	VHDHRW0502A-1	AD		B	Diode(HRW0502A)	[D105]
205	VHDHRW0502A-1	AD		B	Diode(HRW0502A)	[D106]
206	VHDHRW0502A-1	AD		B	Diode(HRW0502A)	[D107]
207	VHDHRW0502A-1	AD		B	Diode(HRW0502A)	[D108]
208	VHDHRW0502A-1	AD		B	Diode(HRW0502A)	[D109]
209	VHDHRW0502A-1	AD		B	Diode(HRW0502A)	[D112]
210	VHDHRW0502A-1	AD		B	Diode(HRW0502A)	[D115]
211	VHDDA204K///-1	AC		B	Diode(DA204K)	[D120]
212	VHDHRW0502A-1	AD		B	Diode(HRW0502A)	[D121]
213	VHDHRW0502A-1	AD		B	Diode(HRW0502A)	[D122]
214	VHDHRW0502A-1	AD		B	Diode(HRW0502A)	[D123]
215	VHDHRW0502A-1	AD		B	Diode(HRW0502A)	[D124]
216	VHDHRW0502A-1	AD		B	Diode(HRW0502A)	[D125]
217	VHDHRW0502A-1	AD		B	Diode(HRW0502A)	[D126]
218	VHDHRW0502A-1	AD		B	Diode(HRW0502A)	[D127]
219	VHDHRW0502A-1	AD		B	Diode(HRW0502A)	[D128]
220	VHDHRW0502A-1	AD		B	Diode(HRW0502A)	[D133]
221	VHDHRW0502A-1	AD		B	Diode(HRW0502A)	[D139]
222	VHDHRW0502A-1	AD		B	Diode(HRW0502A)	[D140]
223	VHD1SS355///-1	AB		B	Diode(1SS355)	[D141]
224	VHDHRW0502A-1	AD		B	Diode(HRW0502A)	[D142]
225	VHDHRW0502A-1	AD		B	Diode(HRW0502A)	[D145]
226	VHD1SS355///-1	AB		B	Diode(1SS355)	[D500]
227	VHD1SS355///-1	AB		B	Diode(1SS355)	[D501]
228	VHVICPS10///-1	AG		B	Varistor	[F100]
229	VHVICPS18///-1	AE		B	Varistor	[F101]
230	VHIBU4066BCF1	AD		B	IC,ANALOG SW(BU4066)	[IC1]
231	VHINJM2904M-1	AE		B	IC,DUAL OP AMP.(NJM2904M)	[IC2]
232	VHILH5116NA10	AL		B	IC,16Kbit SRAM(LH5116NA-10)	[IC3]
233	QSOCZ2066SC42	AP		C	IC Socket(42pin)	[IC4]
234	VHI27160FAB0C	BQ	N	B	IC,16Mbit EPROM(16MB)	[IC4]
235	VHIHD74HC04FM	AC		B	IC,HEX INVERTER(74HC04)	[IC5]
236	VHILC82103/-1	BA		B	IC,IMAGE SIGNAL PROCESSOR(LC82103)	[IC6]
237	VHILB1845///-1	AY		B	IC,Motor Driver(LB1845)	[IC7]
238	VHIHD74HC157F	AH		B	IC,QUAD2-TO-10ATASELECTORS(74HC157)	[IC8]
239	VHI1M16E//J-6	AZ		B	IC,16Mbit DRAM(HY5118164)	[IC9]
240	VHILR38292/-1	AY		B	IC,Gate Array(B)(LR38292)	[IC10]

NO.	PARTS CODE	PRICE RANK	NEW MARK	PART RANK	DESCRIPTION	
[15] Control PWB unit						
241	VHIBA10393F-1	AC		B	IC,COMPARATOR(BA10393F)	[IC11]
242	VHIHD813201F1	BE		B	IC,IDP201(CODEC)(HD813201F)	[IC12]
243	VHIHD74HC32FM	AC		B	IC,QUADRUPLE 2-INPUT OR GATE(74HC32)	[IC13]
244	VHI74VHC04F-1	AE		B	IC,HEX INVERTER(74VHC04)	[IC14]
245	VHIHD74LV08T1	AE		B	IC,QUADRUPLE 2-INPUT AND GATE(74LV08A)	[IC15]
246	VHI1M16E//J-6	AZ		B	IC,16Mbit DRAM(HY5118164)	[IC16]
247	VHILZ9FJ59/-1	AX		B	IC,Gate Array(A)(LZ9FJ59)	[IC17]
248	VHIHD74LS374F	AF		B	IC,OCTAL D-TYPE FLIP-FLOPS(HD74LS374)	[IC18]
249	VHIHD74HC74FM	AD		B	IC,DUAL D-TYPE FLIP-FLOPS(74HC74)	[IC19]
250	VHIHD74LS244F	AF		B	IC,OCTAL BUFFERS(HD74LS244)	[IC20]
251	VHIW24010S7LE	AZ		B	IC,1Mbit SRAM(W24010S-70L)	[IC21]
252	VHIHD74HC14FM	AF		B	IC,SCHMITT-TRIGER INVERTER(74HC14)	[IC22]
253	VHIM65761FP-1	BD	N	B	IC,QM-CODER LSI(M65761FP)	[IC23]
254	VHIHCF4053M1T	AG		B	IC,2ch. ANALOG MULTIPLEXER(HCF4053)	[IC25]
255	VHIHD74HC08FM	AF		B	IC,QUADRUPLE 2-INPUT AND GATE(74HC08)	[IC26]
256	VHIHD7021606A	BE		B	IC,CPU SH-1(MASK)(SH7021)	[IC27]
257	VHIHD74HC08FM	AF		B	IC,QUADRUPLE 2-INPUT AND GATE(74HC08)	[IC28]
258	VHISM8578BV-1	AK		B	IC,Real Time clock(SM8578BV)	[IC30]
259	VHINJM2113M-1	AG		B	IC,SPEAKER AMP.(NJM2113M)	[IC33]
260	VHIHD74HC14FM	AF		B	IC,SCHMITT-TRIGER INVERTER(74HC14)	[IC34]
261	VHI74VHC393FT	AK		B	IC,DUAL D-TYPE FLIP-FLOPS(74VHC393)	[IC35]
262	VHIW24010S7LE	AZ		B	IC,1Mbit SRAM(W24010S-70L)	[IC36]
263	VHIPST596CMT1	AF		B	IC,SYSTEM RESET(PST596)	[IC37]
264	VHIR288F26/-1	BV	N	B	IC,33600bps FAX MODEM(R288F)	[IC41]
265	VHITC7S04FU-1	AD		B	IC,INVERTER(TC7S04FU)	[IC42]
266	VHINJM2902M-1	AF		B	IC,QUADRUPLE OP AMP.(NJM2902M)	[IC43]
267	VHINJM2904M-1	AE		B	IC,DUAL OP AMP.(NJM2904M)	[IC44]
268	VHINJM78M12-1	AG	N	B	IC,REGULATOR(NJM78M12)	[IC45]
269	VHITC7S00FU-1	AE		B	IC,NAND GATE(TC7S00FU)	[IC46]
270	VHIAD8051//1	AN		B	IC,OP AMP.(AD8051)	[IC100]
271	VHITC74HCU04F	AE		B	IC,INVERTER(74HCU04)	[IC101]
272	VHINJM78L05-1	AE		B	IC,REGULATOR(NJM78L05UA)	[IC500]
273	VRS-TS2AD000J	AA		C	Resistor(1/10W 0Ω ±5%)	[L100]
274	VRS-TS2AD000J	AA		C	Resistor(1/10W 0Ω ±5%)	[L101]
275	VRS-TS2AD100J	AA		C	Resistor(1/10W 10Ω ±5%)	[L103]
276	VRS-TS2AD000J	AA		C	Resistor(1/10W 0Ω ±5%)	[L104]
277	VP-1M1R0J0000	AC	N	C	Coil(1μH)	[L500]
278	VRS-TS2AD000J	AA		C	Resistor(1/10W 0Ω ±5%)	[L501]
279	VRS-TS2AD000J	AA		C	Resistor(1/10W 0Ω ±5%)	[L502]
280	VS2SD1164//1	AE		B	Transistor(2SD1164)	[Q1]
281	VS2SD1664Q/-1	AD		B	Transistor(2SD1664Q)	[Q100]
282	VS2SA1037KR-1	AB		C	Transistor(2SA1037K)	[Q101]
283	VSDTC114EK/-1	AB		B	Transistor(DTC114EK)	[Q102]
284	VSDTC114EK/-1	AB		B	Transistor(DTC114EK)	[Q103]
285	VSDTC114EK/-1	AB		B	Transistor(DTC114EK)	[Q104]
286	VSDTC114EK/-1	AB		B	Transistor(DTC114EK)	[Q105]
287	VSDTA114EK/-1	AB		B	Transistor(DTA114EK)	[Q106]
288	VSDTA114EK/-1	AB		B	Transistor(DTA114EK)	[Q107]
289	VSDTC114EK/-1	AB		B	Transistor(DTC114EK)	[Q500]
290	VSDTC114EK/-1	AB		B	Transistor(DTC114EK)	[Q501]
291	VSDTC114EK/-1	AB		B	Transistor(DTC114EK)	[Q502]
292	VRS-HT3AAR47J	AC		C	Resistor(1W 0.47Ω ±5%)	[R1]
293	VRS-HT3AAR47J	AC		C	Resistor(1W 0.47Ω ±5%)	[R2]
294	VRD-HT2HY910J	AA		C	Resistor(1/2W 91Ω ±5%)	[R4]
295	VRD-HT2HY910J	AA		C	Resistor(1/2W 91Ω ±5%)	[R5]
296	VRD-HT2EY000J	AA		C	Resistor(1/4W 0Ω ±5%)	[R6]
297	VRS-TS2AD103J	AA		C	Resistor(1/10W 10KΩ ±5%)	[R101]
298	VRS-TS2AD000J	AA		C	Resistor(1/10W 0Ω ±5%)	[R102]
299	VRS-TS2AD000J	AA		C	Resistor(1/10W 0Ω ±5%)	[R103]
300	VRS-TP2BD222J	AA		C	Resistor(1/8W 2.2KΩ ±5%)	[R104]
301	VRS-TS2AD000J	AA		C	Resistor(1/10W 0Ω ±5%)	[R105]
302	VRS-TS2AD271J	AA		C	Resistor(1/10W 270Ω ±5%)	[R106]
303	VRS-TS2AD330J	AA		C	Resistor(1/10W 33Ω ±5%)	[R107]
304	VRS-TS2AD103J	AA		C	Resistor(1/10W 10KΩ ±5%)	[R108]
305	VRS-TS2AD103J	AA		C	Resistor(1/10W 10KΩ ±5%)	[R110]
306	VRS-TS2AD101J	AA		C	Resistor(1/10W 100Ω ±5%)	[R112]
307	VRS-TS2AD101J	AA		C	Resistor(1/10W 100Ω ±5%)	[R113]
308	VRS-TS2AD105J	AA		C	Resistor(1/10W 1.0MΩ ±5%)	[R114]
309	VRS-TS2AD100J	AA		C	Resistor(1/10W 10Ω ±5%)	[R115]
310	VRS-TS2AD100J	AA		C	Resistor(1/10W 10Ω ±5%)	[R116]
311	VRS-TS2AD103J	AA		C	Resistor(1/10W 10KΩ ±5%)	[R118]
312	VRS-TS2AD271J	AA		C	Resistor(1/10W 270Ω ±5%)	[R119]
313	VRS-TS2AD332J	AA		C	Resistor(1/10W 3.3KΩ ±5%)	[R120]
314	VRS-TS2AD271J	AA		C	Resistor(1/10W 270Ω ±5%)	[R121]
315	VRS-TS2AD103J	AA		C	Resistor(1/10W 10KΩ ±5%)	[R122]
316	VRS-TS2AD562J	AA		C	Resistor(1/10W 5.6KΩ ±5%)	[R123]
317	VRS-TS2AD000J	AA		C	Resistor(1/10W 0Ω ±5%)	[R124]
318	VRS-TS2AD182J	AA		C	Resistor(1/10W 1.8KΩ ±5%)	[R125]
319	VRS-TS2AD302J	AA		C	Resistor(1/10W 3KΩ ±5%)	[R126]
320	VRS-TS2AD000J	AA		C	Resistor(1/10W 0Ω ±5%)	[R128]

NO.	PARTS CODE	PRICE RANK	NEW MARK	PART RANK	DESCRIPTION	
[15] Control PWB unit						
321	VRS-TS2AD000J	AA		C	Resistor(1/10W 0Ω ±5%)	[R129]
322	VRS-TS2AD000J	AA		C	Resistor(1/10W 0Ω ±5%)	[R131]
323	VRS-TS2AD000J	AA		C	Resistor(1/10W 0Ω ±5%)	[R133]
324	VRS-TS2AD000J	AA		C	Resistor(1/10W 0Ω ±5%)	[R134]
325	VRS-TS2AD102J	AA		C	Resistor(1/10W 1KΩ ±5%)	[R136]
326	VRS-TS2AD000J	AA		C	Resistor(1/10W 0Ω ±5%)	[R137]
327	VRS-TS2AD105J	AA		C	Resistor(1/10W 1.0MΩ ±5%)	[R138]
328	VRS-TS2AD000J	AA		C	Resistor(1/10W 0Ω ±5%)	[R139]
329	VRS-TS2AD000J	AA		C	Resistor(1/10W 0Ω ±5%)	[R140]
330	VRS-TS2AD000J	AA		C	Resistor(1/10W 0Ω ±5%)	[R141]
331	VRS-TS2AD223F	AA		C	Resistor(1/10W 22KΩ ±1%)	[R142]
332	VRS-TS2AD563F	AA		C	Resistor(1/10W 56KΩ ±1%)	[R143]
333	VRS-TS2AD333F	AB		C	Resistor(1/10W 33KΩ ±1%)	[R144]
334	VRS-TS2AD393F	AA		C	Resistor(1/10W 39KΩ ±1%)	[R145]
335	VRS-TS2AD102J	AA		C	Resistor(1/10W 1KΩ ±5%)	[R146]
336	VRS-TS2AD472J	AA		C	Resistor(1/10W 4.7KΩ ±5%)	[R147]
337	VRS-TS2AD563F	AA		C	Resistor(1/10W 56KΩ ±1%)	[R148]
338	VRS-TS2AD102J	AA		C	Resistor(1/10W 1KΩ ±5%)	[R149]
339	VRS-TS2AD330J	AA		C	Resistor(1/10W 33Ω ±5%)	[R158]
340	VRS-TS2AD330J	AA		C	Resistor(1/10W 33Ω ±5%)	[R159]
341	VRS-TS2AD332J	AA		C	Resistor(1/10W 3.3KΩ ±5%)	[R160]
342	VRS-TS2AD102J	AA		C	Resistor(1/10W 1KΩ ±5%)	[R161]
343	VRS-TS2AD271J	AA		C	Resistor(1/10W 270Ω ±5%)	[R162]
344	VRS-TS2AD271J	AA		C	Resistor(1/10W 270Ω ±5%)	[R163]
345	VRS-TS2AD271J	AA		C	Resistor(1/10W 270Ω ±5%)	[R164]
346	VRS-TS2AD271J	AA		C	Resistor(1/10W 270Ω ±5%)	[R165]
347	VRS-TS2AD271J	AA		C	Resistor(1/10W 270Ω ±5%)	[R167]
348	VRS-TS2AD271J	AA		C	Resistor(1/10W 270Ω ±5%)	[R168]
349	VRS-TS2AD271J	AA		C	Resistor(1/10W 270Ω ±5%)	[R169]
350	VRS-TS2AD271J	AA		C	Resistor(1/10W 270Ω ±5%)	[R170]
351	VRS-TS2AD302J	AA		C	Resistor(1/10W 3KΩ ±5%)	[R171]
352	VRS-TS2AD000J	AA		C	Resistor(1/10W 0Ω ±5%)	[R172]
353	VRS-TS2AD271J	AA		C	Resistor(1/10W 270Ω ±5%)	[R173]
354	VRS-TS2AD000J	AA		C	Resistor(1/10W 0Ω ±5%)	[R175]
355	VRS-TS2AD271J	AA		C	Resistor(1/10W 270Ω ±5%)	[R176]
356	VRS-TS2AD271J	AA		C	Resistor(1/10W 270Ω ±5%)	[R177]
357	VRS-TS2AD103J	AA		C	Resistor(1/10W 10KΩ ±5%)	[R178]
358	VRS-TS2AD562J	AA		C	Resistor(1/10W 5.6KΩ ±5%)	[R179]
359	VRS-TS2AD103J	AA		C	Resistor(1/10W 10KΩ ±5%)	[R181]
360	VRS-TS2AD271J	AA		C	Resistor(1/10W 270Ω ±5%)	[R182]
361	VRS-TS2AD103J	AA		C	Resistor(1/10W 10KΩ ±5%)	[R183]
362	VRS-TS2AD472J	AA		C	Resistor(1/10W 4.7KΩ ±5%)	[R184]
363	VRS-TS2AD103J	AA		C	Resistor(1/10W 10KΩ ±5%)	[R185]
364	VRS-TS2AD103J	AA		C	Resistor(1/10W 10KΩ ±5%)	[R186]
365	VRS-TS2AD103J	AA		C	Resistor(1/10W 10KΩ ±5%)	[R188]
366	VRS-TS2AD472J	AA		C	Resistor(1/10W 4.7KΩ ±5%)	[R189]
367	VRS-TS2AD101J	AA		C	Resistor(1/10W 100Ω ±5%)	[R190]
368	VRS-TS2AD101J	AA		C	Resistor(1/10W 100Ω ±5%)	[R191]
369	VRS-TS2AD000J	AA		C	Resistor(1/10W 0Ω ±5%)	[R192]
370	VRS-TS2AD000J	AA		C	Resistor(1/10W 0Ω ±5%)	[R193]
371	VRS-TS2AD000J	AA		C	Resistor(1/10W 0Ω ±5%)	[R194]
372	VRS-TS2AD000J	AA		C	Resistor(1/10W 0Ω ±5%)	[R195]
373	VRS-TS2AD000J	AA		C	Resistor(1/10W 0Ω ±5%)	[R196]
374	VRS-TS2AD472J	AA		C	Resistor(1/10W 4.7KΩ ±5%)	[R197]
375	VRS-TS2AD472J	AA		C	Resistor(1/10W 4.7KΩ ±5%)	[R198]
376	VRS-TS2AD000J	AA		C	Resistor(1/10W 0Ω ±5%)	[R199]
377	VRS-TS2AD471J	AA		C	Resistor(1/10W 470Ω ±5%)	[R200]
378	VRS-TS2AD000J	AA		C	Resistor(1/10W 0Ω ±5%)	[R201]
379	VRS-TS2AD103J	AA		C	Resistor(1/10W 10KΩ ±5%)	[R202]
380	VRS-TS2AD472J	AA		C	Resistor(1/10W 4.7KΩ ±5%)	[R203]
381	VRS-TS2AD331J	AA		C	Resistor(1/10W 330Ω ±5%)	[R204]
382	VRS-TS2AD330J	AA		C	Resistor(1/10W 33Ω ±5%)	[R205]
383	VRS-TS2AD472J	AA		C	Resistor(1/10W 4.7KΩ ±5%)	[R206]
384	VRS-TS2AD472J	AA		C	Resistor(1/10W 4.7KΩ ±5%)	[R207]
385	VRS-TS2AD472J	AA		C	Resistor(1/10W 4.7KΩ ±5%)	[R208]
386	VRS-TS2AD101J	AA		C	Resistor(1/10W 100Ω ±5%)	[R209]
387	VRS-TS2AD271J	AA		C	Resistor(1/10W 270Ω ±5%)	[R210]
388	VRS-TS2AD332J	AA		C	Resistor(1/10W 3.3KΩ ±5%)	[R211]
389	VRS-TS2AD332J	AA		C	Resistor(1/10W 3.3KΩ ±5%)	[R212]
390	VRS-TS2AD332J	AA		C	Resistor(1/10W 3.3KΩ ±5%)	[R213]
391	VRS-TS2AD105J	AA		C	Resistor(1/10W 1.0MΩ ±5%)	[R214]
392	VRS-TS2AD561J	AA		C	Resistor(1/10W 270Ω ±5%)	[R215]
393	VRS-TS2AD271J	AA		C	Resistor(1/10W 270Ω ±5%)	[R216]
394	VRS-TS2AD271J	AA		C	Resistor(1/10W 150Ω ±5%)	[R217]
395	VRS-TS2AD151J	AA		C	Resistor(1/10W 150Ω ±5%)	[R218]
396	VRS-TS2AD151J	AA		C	Resistor(1/10W 150Ω ±5%)	[R219]
397	VRS-TS2AD151J	AA		C	Resistor(1/10W 150Ω ±5%)	[R220]
398	VRS-TS2AD103J	AA		C	Resistor(1/10W 10KΩ ±5%)	[R222]
399	VRS-TS2AD000J	AA		C	Resistor(1/10W 0Ω ±5%)	[R223]
400	VRS-TS2AD271J	AA		C	Resistor(1/10W 270Ω ±5%)	[R224]

NO.	PARTS CODE	PRICE RANK	NEW MARK	PART RANK	DESCRIPTION	
[15] Control PWB unit						
401	VRS-TS2AD271J	AA		C	Resistor(1/10W 270Ω ±5%)	[R225]
402	VRS-TS2AD000J	AA		C	Resistor(1/10W 0Ω ±5%)	[R226]
403	VRS-TS2AD000J	AA		C	Resistor(1/10W 0Ω ±5%)	[R227]
404	VRS-TS2AD000J	AA		C	Resistor(1/10W 0Ω ±5%)	[R228]
405	VRS-TS2AD000J	AA		C	Resistor(1/10W 0Ω ±5%)	[R229]
406	VRS-TS2AD000J	AA		C	Resistor(1/10W 0Ω ±5%)	[R230]
407	VRS-TS2AD103J	AA		C	Resistor(1/10W 10KΩ ±5%)	[R233]
408	VRS-TS2AD000J	AA		C	Resistor(1/10W 0Ω ±5%)	[R234]
409	VRS-TS2AD103J	AA		C	Resistor(1/10W 10KΩ ±5%)	[R235]
410	VRS-TS2AD000J	AA		C	Resistor(1/10W 0Ω ±5%)	[R236]
411	VRS-TS2AD000J	AA		C	Resistor(1/10W 0Ω ±5%)	[R237]
412	VRS-TS2AD000J	AA		C	Resistor(1/10W 0Ω ±5%)	[R238]
413	VRS-TS2AD103J	AA		C	Resistor(1/10W 10KΩ ±5%)	[R239]
414	VRS-TS2AD103J	AA		C	Resistor(1/10W 10KΩ ±5%)	[R240]
415	VRS-TS2AD000J	AA		C	Resistor(1/10W 0Ω ±5%)	[R241]
416	VRS-TS2AD000J	AA		C	Resistor(1/10W 0Ω ±5%)	[R242]
417	VRS-TS2AD000J	AA		C	Resistor(1/10W 0Ω ±5%)	[R243]
418	VRS-TS2AD472J	AA		C	Resistor(1/10W 4.7KΩ ±5%)	[R244]
419	VRS-TS2AD000J	AA		C	Resistor(1/10W 0Ω ±5%)	[R245]
420	VRS-TS2AD103J	AA		C	Resistor(1/10W 10KΩ ±5%)	[R246]
421	VRS-TS2AD103J	AA		C	Resistor(1/10W 10KΩ ±5%)	[R247]
422	VRS-TS2AD103J	AA		C	Resistor(1/10W 10KΩ ±5%)	[R248]
423	VRS-TS2AD103J	AA		C	Resistor(1/10W 10KΩ ±5%)	[R249]
424	VRS-TS2AD472J	AA		C	Resistor(1/10W 4.7KΩ ±5%)	[R250]
425	VRS-TS2AD203J	AA		C	Resistor(1/10W 20KΩ ±5%)	[R251]
426	VRS-TS2AD101J	AA		C	Resistor(1/10W 100Ω ±5%)	[R254]
427	VRS-TS2AD101J	AA		C	Resistor(1/10W 100Ω ±5%)	[R255]
428	VRS-TS2AD472J	AA		C	Resistor(1/10W 4.7KΩ ±5%)	[R256]
429	VRS-TS2AD472J	AA		C	Resistor(1/10W 4.7KΩ ±5%)	[R257]
430	VRS-TS2AD472J	AA		C	Resistor(1/10W 4.7KΩ ±5%)	[R258]
431	VRS-TS2AD000J	AA		C	Resistor(1/10W 0Ω ±5%)	[R260]
432	VRS-TS2AD000J	AA		C	Resistor(1/10W 0Ω ±5%)	[R262]
433	VRS-TS2AD000J	AA		C	Resistor(1/10W 0Ω ±5%)	[R263]
434	VRS-TS2AD222J	AA		C	Resistor(1/10W 2.2KΩ ±5%)	[R264]
435	VRS-TS2AD000J	AA		C	Resistor(1/10W 0Ω ±5%)	[R266]
436	VRS-TS2AD000J	AA		C	Resistor(1/10W 0Ω ±5%)	[R267]
437	VRS-TS2AD103J	AA		C	Resistor(1/10W 10KΩ ±5%)	[R268]
438	VRS-TS2AD103J	AA		C	Resistor(1/10W 10KΩ ±5%)	[R269]
439	VRS-TS2AD183J	AA		C	Resistor(1/10W 18KΩ ±5%)	[R290]
440	VRS-TS2AD000J	AA		C	Resistor(1/10W 0Ω ±5%)	[R291]
441	VRS-TS2AD183J	AA		C	Resistor(1/10W 18KΩ ±5%)	[R292]
442	VRS-TS2AD103J	AA		C	Resistor(1/10W 10KΩ ±5%)	[R293]
443	VRS-TS2AD103J	AA		C	Resistor(1/10W 10KΩ ±5%)	[R294]
444	VRS-TS2AD203J	AA		C	Resistor(1/10W 20KΩ ±5%)	[R295]
445	VRS-TS2AD203J	AA		C	Resistor(1/10W 20KΩ ±5%)	[R296]
446	VRS-TS2AD102J	AA		C	Resistor(1/10W 1KΩ ±5%)	[R297]
447	VRS-TS2AD103J	AA		C	Resistor(1/10W 10KΩ ±5%)	[R299]
448	VRS-TS2AD000J	AA		C	Resistor(1/10W 0Ω ±5%)	[R300]
449	VRS-TS2AD472J	AA		C	Resistor(1/10W 4.7KΩ ±5%)	[R301]
450	VRS-TS2AD000J	AA		C	Resistor(1/10W 0Ω ±5%)	[R302]
451	VRS-TS2AD472J	AA		C	Resistor(1/10W 4.7KΩ ±5%)	[R305]
452	VRS-TS2AD561J	AA		C	Resistor(1/10W 560Ω ±5%)	[R307]
453	VRS-TS2AD472J	AA		C	Resistor(1/10W 4.7KΩ ±5%)	[R310]
454	VRS-TS2AD472J	AA		C	Resistor(1/10W 4.7KΩ ±5%)	[R314]
455	VRS-TS2AD472J	AA		C	Resistor(1/10W 4.7KΩ ±5%)	[R315]
456	VRS-TS2AD472J	AA		C	Resistor(1/10W 4.7KΩ ±5%)	[R316]
457	VRS-TS2AD000J	AA		C	Resistor(1/10W 0Ω ±5%)	[R317]
458	VRS-TS2AD100J	AA		C	Resistor(1/10W 10Ω ±5%)	[R318]
459	VRS-TS2AD100J	AA		C	Resistor(1/10W 10Ω ±5%)	[R319]
460	VRS-TS2AD103J	AA		C	Resistor(1/10W 10KΩ ±5%)	[R320]
461	VRS-TS2AD103J	AA		C	Resistor(1/10W 10KΩ ±5%)	[R321]
462	VRS-TS2AD103J	AA		C	Resistor(1/10W 10KΩ ±5%)	[R324]
463	VRS-TS2AD472J	AA		C	Resistor(1/10W 4.7KΩ ±5%)	[R325]
464	VRS-TS2AD103J	AA		C	Resistor(1/10W 10KΩ ±5%)	[R328]
465	VRS-TS2AD562J	AA		C	Resistor(1/10W 5.6KΩ ±5%)	[R329]
466	VRS-TS2AD154J	AA		C	Resistor(1/10W 150KΩ ±5%)	[R360]
467	VRS-TS2AD302J	AA		C	Resistor(1/10W 3KΩ ±5%)	[R363]
468	VRS-TS2AD103J	AA		C	Resistor(1/10W 10KΩ ±5%)	[R364]
469	VRS-TS2AD104J	AA		C	Resistor(1/10W 100KΩ ±5%)	[R365]
470	VRS-TS2AD103J	AA		C	Resistor(1/10W 10KΩ ±5%)	[R367]
471	VRS-TS2AD471J	AA		C	Resistor(1/10W 470Ω ±5%)	[R368]
472	VRS-TS2AD102J	AA		C	Resistor(1/10W 1KΩ ±5%)	[R369]
473	VRS-TS2AD102J	AA		C	Resistor(1/10W 1KΩ ±5%)	[R370]
474	VRS-TS2AD333J	AA		C	Resistor(1/10W 33KΩ ±5%)	[R371]
475	VRS-TS2AD101J	AA		C	Resistor(1/10W 100Ω ±5%)	[R373]
476	VRS-TP2BD000J	AA		C	Resistor(1/8W 0Ω ±5%)	[R374]
477	VRS-TS2AD472J	AA		C	Resistor(1/10W 4.7KΩ ±5%)	[R375]
478	VRS-TS2AD472J	AA		C	Resistor(1/10W 4.7KΩ ±5%)	[R376]
479	VRS-TS2AD102J	AA		C	Resistor(1/10W 1KΩ ±5%)	[R377]
480	VRS-TS2AD000J	AA		C	Resistor(1/10W 0Ω ±5%)	[R378]

NO.	PARTS CODE	PRICE RANK	NEW MARK	PART RANK	DESCRIPTION	
[15] Control PWB unit						
481	VRS-TS2AD000J	AA		C	Resistor(1/10W 0Ω ±5%)	[R379]
482	VRS-TS2AD103J	AA		C	Resistor(1/10W 10KΩ ±5%)	[R380]
483	VRS-TS2AD103J	AA		C	Resistor(1/10W 10KΩ ±5%)	[R381]
484	VRS-TS2AD103J	AA		C	Resistor(1/10W 10KΩ ±5%)	[R382]
485	VRS-TS2AD472J	AA		C	Resistor(1/10W 4.7KΩ ±5%)	[R383]
486	VRS-TS2AD472J	AA		C	Resistor(1/10W 4.7KΩ ±5%)	[R384]
487	VRS-TS2AD472J	AA		C	Resistor(1/10W 4.7KΩ ±5%)	[R385]
488	VRS-TS2AD000J	AA		C	Resistor(1/10W 0Ω ±5%)	[R400]
489	VRS-TS2AD100J	AA		C	Resistor(1/10W 10Ω ±5%)	[R402]
490	VRS-TS2AD101J	AA		C	Resistor(1/10W 100Ω ±5%)	[R404]
491	VRS-TS2AD103J	AA		C	Resistor(1/10W 10KΩ ±5%)	[R406]
492	VRS-TS2AD103J	AA		C	Resistor(1/10W 10KΩ ±5%)	[R407]
493	VRS-TS2AD103J	AA		C	Resistor(1/10W 10KΩ ±5%)	[R408]
494	VRS-TS2AD103J	AA		C	Resistor(1/10W 10KΩ ±5%)	[R409]
495	VRS-TS2AD271J	AA		C	Resistor(1/10W 270Ω ±5%)	[R410]
496	VRS-TS2AD471J	AA		C	Resistor(1/10W 470Ω ±5%)	[R411]
497	VRS-TS2AD471J	AA		C	Resistor(1/10W 470Ω ±5%)	[R412]
498	VRS-TS2AD271J	AA		C	Resistor(1/10W 270Ω ±5%)	[R413]
499	VRS-TS2AD000J	AA		C	Resistor(1/10W 0Ω ±5%)	[R415]
500	VRS-TS2AD472J	AA		C	Resistor(1/10W 4.7KΩ ±5%)	[R416]
501	VRS-TS2AD103J	AA		C	Resistor(1/10W 10KΩ ±5%)	[R419]
502	VRS-TS2AD000J	AA		C	Resistor(1/10W 0Ω ±5%)	[R422]
503	VRS-TS2AD000J	AA		C	Resistor(1/10W 0Ω ±5%)	[R423]
504	VRS-TS2AD330J	AA		C	Resistor(1/10W 33Ω ±5%)	[R424]
505	VRS-TS2AD000J	AA		C	Resistor(1/10W 0Ω ±5%)	[R425]
506	VRS-TS2AD151J	AA		C	Resistor(1/10W 150Ω ±5%)	[R426]
507	VRS-TS2AD000J	AA		C	Resistor(1/10W 0Ω ±5%)	[R427]
508	VRS-TS2AD000J	AA		C	Resistor(1/10W 0Ω ±5%)	[R428]
509	VRS-TS2AD000J	AA		C	Resistor(1/10W 0Ω ±5%)	[R429]
510	VRS-TS2AD100J	AA		C	Resistor(1/10W 10Ω ±5%)	[R501]
511	VRS-TS2AD100J	AA		C	Resistor(1/10W 10Ω ±5%)	[R502]
512	VRS-TS2AD100J	AA		C	Resistor(1/10W 10Ω ±5%)	[R503]
513	VRS-TS2AD100J	AA		C	Resistor(1/10W 10Ω ±5%)	[R504]
514	VRS-TS2AD100J	AA		C	Resistor(1/10W 10Ω ±5%)	[R505]
515	VRS-TS2AD100J	AA		C	Resistor(1/10W 10Ω ±5%)	[R506]
516	VRS-TS2AD100J	AA		C	Resistor(1/10W 10Ω ±5%)	[R507]
517	VRS-TS2AD100J	AA		C	Resistor(1/10W 10Ω ±5%)	[R508]
518	VRS-TS2AD100J	AA		C	Resistor(1/10W 10Ω ±5%)	[R509]
519	VRS-TS2AD100J	AA		C	Resistor(1/10W 10Ω ±5%)	[R510]
520	VRS-TS2AD100J	AA		C	Resistor(1/10W 10Ω ±5%)	[R511]
521	VRS-TS2AD100J	AA		C	Resistor(1/10W 10Ω ±5%)	[R512]
522	VRS-TS2AD100J	AA		C	Resistor(1/10W 10Ω ±5%)	[R513]
523	VRS-TS2AD100J	AA		C	Resistor(1/10W 10Ω ±5%)	[R514]
524	VRS-TS2AD100J	AA		C	Resistor(1/10W 10Ω ±5%)	[R515]
525	VRS-TS2AD100J	AA		C	Resistor(1/10W 10Ω ±5%)	[R516]
526	VRS-TS2AD100J	AA		C	Resistor(1/10W 10Ω ±5%)	[R517]
527	VRS-TS2AD101J	AA		C	Resistor(1/10W 100Ω ±5%)	[R519]
528	VRS-TS2AD103J	AA		C	Resistor(1/10W 10KΩ ±5%)	[R520]
529	VRS-TS2AD103J	AA		C	Resistor(1/10W 10KΩ ±5%)	[R521]
530	VRS-TS2AD103J	AA		C	Resistor(1/10W 10KΩ ±5%)	[R522]
531	VRS-TS2AD103J	AA		C	Resistor(1/10W 10KΩ ±5%)	[R523]
532	VRS-TS2AD103J	AA		C	Resistor(1/10W 10KΩ ±5%)	[R524]
533	VRSTS2AD4422F	AA		C	Resistor(1/10W 44.2KΩ ±1%)	[R525]
534	VRSTS2AD4422F	AA		C	Resistor(1/10W 44.2KΩ ±1%)	[R526]
535	VRSTS2AD4422F	AA		C	Resistor(1/10W 44.2KΩ ±1%)	[R527]
536	VRSTS2AD4422F	AA		C	Resistor(1/10W 44.2KΩ ±1%)	[R528]
537	VRSTS2AD6812F	AA		C	Resistor(1/10W 68.1KΩ ±1%)	[R529]
538	VRSTS2AD1373F	AA		C	Resistor(1/10W 137KΩ ±1%)	[R530]
539	VRS-TS2AD000J	AA		C	Resistor(1/10W 0Ω ±5%)	[R531]
540	VRS-TS2AD333J	AA		C	Resistor(1/10W 33KΩ ±5%)	[R532]
541	VRS-TS2AD333J	AA		C	Resistor(1/10W 33KΩ ±5%)	[R533]
542	VRS-TS2AD000J	AA		C	Resistor(1/10W 0Ω ±5%)	[R534]
543	VRS-TP2BD200J	AA		C	Resistor(1/8W 20Ω ±5%)	[R535]
544	VRS-TS2AD000J	AA		C	Resistor(1/10W 0Ω ±5%)	[R536]
545	VRS-TS2AD000J	AA		C	Resistor(1/10W 0Ω ±5%)	[R537]
546	VRS-TS2AD103J	AA		C	Resistor(1/10W 10KΩ ±5%)	[R538]
547	VRS-TS2AD822J	AA		C	Resistor(1/10W 8.2KΩ ±5%)	[R539]
548	VRS-TS2AD223J	AA		C	Resistor(1/10W 22K ±5%)	[R540]
549	VRS-TS2AD273J	AA		C	Resistor(1/10W 27KΩ ±5%)	[R541]
550	VRS-TS2AD513J	AA		C	Resistor(1/10W 51KΩ ±5%)	[R542]
551	VRS-TS2AD332J	AA		C	Resistor(1/10W 3.3KΩ ±5%)	[R543]
552	VRS-TS2AD153J	AA		C	Resistor(1/10W 15KΩ ±5%)	[R544]
553	VRS-TS2AD223J	AA		C	Resistor(1/10W 22KΩ ±5%)	[R545]
554	VRS-TS2AD273J	AA		C	Resistor(1/10W 27KΩ ±5%)	[R546]
555	VRS-TS2AD113J	AA		C	Resistor(1/10W 11KΩ ±5%)	[R547]
556	VRS-TS2AD223J	AA		C	Resistor(1/10W 22KΩ ±5%)	[R548]
557	VRS-TS2AD332J	AA		C	Resistor(1/10W 3.3KΩ ±5%)	[R549]
558	VRS-TS2AD332J	AA		C	Resistor(1/10W 3.3KΩ ±5%)	[R550]
559	VRS-TS2AD332J	AA		C	Resistor(1/10W 3.3KΩ ±5%)	[R551]
560	VRS-TS2AD101J	AA		C	Resistor(1/10W 100Ω ±5%)	[R552]

NO.	PARTS CODE	PRICE RANK	NEW MARK	PART RANK	DESCRIPTION	
[15] Control PWB unit						
561	VRS-TS2AD101J	AA		C	Resistor(1/10W 100Ω ±5%)	[R553]
562	VRS-TS2AD000J	AA		C	Resistor(1/10W 0Ω ±5%)	[R554]
563	VRS-TS2AD000J	AA		C	Resistor(1/10W 0Ω ±5%)	[R555]
564	RR-TZ3016SCZZ	AA		C	Resistor(33Ωx4)	[RA1]
565	RR-TZ3016SCZZ	AA		C	Resistor(33Ωx4)	[RA2]
566	RR-TZ3016SCZZ	AA		C	Resistor(33Ωx4)	[RA3]
567	RR-TZ3016SCZZ	AA		C	Resistor(33Ωx4)	[RA4]
568	RR-TZ3018SCZZ	AC		C	Block resistor(470Ωx4)	[RA14]
569	RR-TZ3018SCZZ	AC		C	Block resistor(470Ωx4)	[RA15]
570	RCRSZ2150XHZZ	AF		B	Crystal(24.32MHz)	[X1]
571	RCRSZ2158XHZZ	AF		B	Crystal(16.00MHz)	[X2]
572	RCRSZ2151XHZZ	AF		B	Crystal(20.31092MHz)	[X3]
573	RCRSQ2163XHZZ	AN	N	B	Crystal(56.448MHz)	[X4]
574	RCRSZ2152XHZZ	AF		B	Crystal(19.6608MHz)	[X5]
575	RCRSP0074AFZZ	AE		B	Crystal(32.768kHz)	[X6]
	(Unit)					
901	DCEKC489MXHZZ	CL	N	E	Control PWB unit(Within ROM)	
[16] Liu PWB unit						
1	VHVRA391PV6-1	AE		B	Varistor(RA391PV6)	[AR1]
2	QTANZ2042SCZZ	AB		C	Terminal	[ARG]
3	RC-FZ3024SCZZ	AG		C	Capacitor(250WV 0.82μF)	[C1]
4	VCKYPU1HB103K	AA		C	Capacitor(50WV 0.010μF)	[C2]
5	VCKYPU1HF223Z	AA		C	Capacitor(50WV 0.022μF)	[C3]
6	VCEAGA1HW225M	AA		C	Capacitor(50WV 2.2μF)	[C5]
7	VEEAGA1HW225M	AB	N	C	Capacitor(50WV 2.2μF)	[C6]
8	VCKYPU1HB102K	AA		C	Capacitor(50WV 1000PF)	[C7]
9	VCQYNA1HM333K	AA		C	Capacitor(50WV 0.033μF)	[C8]
10	VCKYPU1HB102K	AA		C	Capacitor(50WV 1000PF)	[C9]
11	VCEAGA1HW475M	AA		C	Capacitor(50WV 4.7μF)	[C10]
12	VCEAGA1HW475M	AA		C	Capacitor(50WV 4.7μF)	[C11]
13	VCEAGA1HW475M	AA		C	Capacitor(50WV 4.7μF)	[C12]
14	VCKYPU1HB471K	AA		C	Capacitor(50WV 470PF)	[C15]
15	VCQYNA1HM333K	AA		C	Capacitor(50WV 0.033μF)	[C16]
16	VCEAGA1HW107M	AA		C	Capacitor(50WV 100μF)	[C18]
17	VCKYPU1HF223Z	AA		C	Capacitor(50WV 0.022μF)	[C19]
18	RRLYD3433XHZZ	AH		B	Relay	[CML]
19	QCNCW2500SC0I	AF		C	Connector(9pin)	[CNLIU]
20	VHDDSS133/-1	AA		B	Diode(1SS133)	[D1]
21	VHDDSS133/-1	AA		B	Diode(1SS133)	[D2]
22	VHINJM2904D-1	AG		B	IC,OP AMP.(NJM2904D)	[IC1]
23	VRD-HT2EY100J	AA		C	Resistor(1/4W 10W ±5%)	[J3]
24	QJAKZ2046SCBB	AH		C	Jack(2pin)	[MJI-2]
25	VHPTLP521-1BL	AE		B	Photo coupler(TLP521)	[PC1]
26	VHPTLP627/-1	AH		B	Photo coupler(TLP627)	[PC2]
27	VHPPC814X/-1	AE		B	Photo transistor(PC814X)	[PC3]
28	VS2SD592A-S-1	AK		B	Transistor(2SD592A-S)	[Q1]
29	VS2SD1200FR-1	AE		B	Transistor(2SD1200FR)	[Q2]
30	VS2SA1807-P-1	AE		B	Transistor(2SA1807)	[Q3]
31	VSDTC114ES/-1	AB		B	Transistor(DTC114ES)	[Q4]
32	VSDTC114ES/-1	AB		B	Transistor(DTC114ES)	[Q5]
33	VRD-HT2EY224J	AA		C	Resistor(1/4W 220KΩ ±5%)	[R2]
34	VRD-HT2EY104J	AA		C	Resistor(1/4W 100KΩ ±5%)	[R3]
35	RR-HZ3011SCZZ	AC		C	Resistor(1/2W 4.7Ω ±5%)	[R4]
36	VRS-HT3AA133J	AB		C	Resistor(1W 13KΩ ±5%)	[R5]
37	VRD-HT2HY223J	AA		C	Resistor(1/2W 22KΩ ±5%)	[R6]
38	VRD-HT2EY124J	AA		C	Resistor(1/4W 120KΩ ±5%)	[R7]
39	VRD-HT2EY472J	AA		C	Resistor(1/4W 4.7KΩ ±5%)	[R8]
40	VRD-HT2EY183J	AA		C	Resistor(1/4W 18KΩ ±5%)	[R9]
41	VRD-HT2EY100J	AA		C	Resistor(1/4W 10Ω ±5%)	[R10]
42	VRD-HT2EY303J	AA		C	Resistor(1/4W 30KΩ ±5%)	[R11]
43	VRD-HT2EY910J	AA		C	Resistor(1/4W 91Ω ±5%)	[R12]
44	VRD-HT2EY300J	AA		C	Resistor(1/4W 30Ω ±5%)	[R13]
45	VRD-HT2EY201J	AA		C	Resistor(1/4W 200Ω ±5%)	[R14]
46	VRD-HT2EY621J	AA		C	Resistor(1/4W 620Ω ±5%)	[R15]
47	VRD-HT2EY621J	AA		C	Resistor(1/4W 620Ω ±5%)	[R16]
48	VRD-HT2EY223J	AA		C	Resistor(1/4W 22KΩ ±5%)	[R17]
49	VRD-HT2EY223J	AA		C	Resistor(1/4W 22KΩ ±5%)	[R18]
50	VRD-HT2EY751J	AA		C	Resistor(1/4W 750Ω ±5%)	[R19]
51	VRD-HT2EY223J	AA		C	Resistor(1/4W 22KΩ ±5%)	[R20]
52	VRD-HT2EY332J	AA		C	Resistor(1/4W 3.3KΩ ±5%)	[R21]
53	VRD-HT2EY223J	AA		C	Resistor(1/4W 22KΩ ±5%)	[R22]
54	VRD-HT2EY103J	AA		C	Resistor(1/4W 10KΩ ±5%)	[R24]
55	VRD-HT2EY103J	AA		C	Resistor(1/4W 10KΩ ±5%)	[R26]
56	VHD0R5G4B42-1S	AF		B	Bridge diode(0R5G4B42)	[REC]
57	RTRNZ2163SCZZ	AH		B	Transformer	[T1]

NO.	PARTS CODE	PRICE RANK	NEW MARK	PART RANK	DESCRIPTION
[16] Liu PWB unit					
58	VHVERZV5D471/	AC		B	Varistor(ERZVA5D471) [VA1]
59	VHVERZV5D471/	AC		B	Varistor(ERZVA5D471) [VA2]
60	VHVTN07G101-1	AB		B	Varistor(TNR7G101KT2) [VA3]
61	VHEHZ2C1///-1	AA		B	Zener diode(HZ2C1-TA) [ZD1]
62	VHEHZ2C1///-1	AA		B	Zener diode(HZ2C1-TA) [ZD2]
63	VHEHZ27-1//1	AB		B	Zener diode(HZ27C-1TA) [ZD3]
64	VHE1ZC15///-1	AC		B	Zener diode(1ZC15) [ZD4]
65	VHEMTZJ8R2B-1	AC		B	Zener diode(MTZJ8R2B) [ZD5]
66	VHEHZ2C1///-1	AA		B	Zener diode(HZ2C1-TA) [ZD6]
67	VHEHZ2C1///-1	AA		B	Zener diode(HZ2C1-TA) [ZD7]
	(Unit)				
901	DCEKL471BXH01	AZ		E	LIU PWB unit
[17] Printer PWB unit					
1	VCEAGA1VW476M	AB		C	Capacitor(35WV 47μF) [C1]
2	VCEAGA1CW227M	AB		C	Capacitor(16WV 220μF) [C2]
3	VCKYTV1EF103Z	AA		C	Capacitor(25WV 0.010μF) [C100]
4	VCKYTV1EF103Z	AA		C	Capacitor(25WV 0.010μF) [C101]
5	VCKYTV1EB821K	AC		C	Capacitor(25WV 820PF) [C102]
6	VCKYTV1EF103Z	AA		C	Capacitor(25WV 0.010μF) [C103]
7	VCKYTV1EB102K	AD		C	Capacitor(25WV 1000PF) [C104]
8	VCKYTV1EF103Z	AA		C	Capacitor(25WV 0.010μF) [C105]
9	VCKYTV1EF103Z	AA		C	Capacitor(25WV 0.010μF) [C106]
10	VCKYTV1EF103Z	AA		C	Capacitor(25WV 0.010μF) [C107]
11	VCKYTV1EF103Z	AA		C	Capacitor(25WV 0.010μF) [C108]
12	VCKYTV1EF103Z	AA		C	Capacitor(25WV 0.010μF) [C109]
13	VCKYTV1EF103Z	AA		C	Capacitor(25WV 0.010μF) [C110]
14	VCKYTV1EF103Z	AA		C	Capacitor(25WV 0.010μF) [C111]
15	VCKYTV1EF103Z	AA		C	Capacitor(25WV 0.010μF) [C112]
16	VCKYTV1EF103Z	AA		C	Capacitor(25WV 0.010μF) [C113]
17	VCKYTV1EF103Z	AA		C	Capacitor(25WV 0.010μF) [C114]
18	VCKYTV1EB821K	AC		C	Capacitor(25WV 820PF) [C115]
19	VCKYTV1EF103Z	AA		C	Capacitor(25WV 0.010μF) [C116]
20	VCKYTV1HF104Z	AA		C	Capacitor(50WV 0.1μF) [C119]
21	VCKYTV1EF103Z	AA		C	Capacitor(25WV 0.010μF) [C120]
22	VCKYTV1EF103Z	AA		C	Capacitor(25WV 0.010μF) [C121]
23	VCKYTV1EF103Z	AA		C	Capacitor(25WV 0.010μF) [C122]
24	VCKYTV1EB102K	AD		C	Capacitor(25WV 1000PF) [C123]
25	VCKYTV1EB102K	AD		C	Capacitor(25WV 1000PF) [C125]
26	VCKYTV1EF103Z	AA		C	Capacitor(25WV 0.010μF) [C126]
27	VCKYTV1EB102K	AD		C	Capacitor(25WV 1000PF) [C127]
28	VCKYTV1CF105Z	AB		C	Capacitor(16WV 1μF) [C129]
29	VCCCTV1HH180J	AA		C	Capacitor(50WV 18PF) [C130]
30	VCCCTV1HH180J	AA		C	Capacitor(50WV 18PF) [C131]
31	VCKYTV1HF104Z	AA		C	Capacitor(50WV 0.1μF) [C132]
32	VCKYTV1EB821K	AC		C	Capacitor(25WV 820PF) [C133]
33	VCKYTV1EF103Z	AA		C	Capacitor(25WV 0.010μF) [C134]
34	VCKYTV1EB102K	AD		C	Capacitor(25WV 1000PF) [C137]
35	VCKYTV1EB102K	AD		C	Capacitor(25WV 1000PF) [C138]
36	VCKYTV1EB102K	AD		C	Capacitor(25WV 1000PF) [C139]
37	VCKYTV1EB102K	AD		C	Capacitor(25WV 1000PF) [C140]
38	VCKYTV1EB821K	AC		C	Capacitor(25WV 820PF) [C141]
39	VCKYTV1HF104Z	AA		C	Capacitor(50WV 0.1μF) [C142]
40	VCKYTV1EF333Z	AB		C	Capacitor(25WV 0.033μF) [C143]
41	VCKYTV1HF104Z	AA		C	Capacitor(50WV 0.1μF) [C144]
42	VCKYTV1EB102K	AD		C	Capacitor(25WV 1000PF) [C145]
43	RC-FZ3039XHZZ	AB		C	Capacitor [C147]
44	VCKYTV1HF104Z	AA		C	Capacitor(50WV 0.1μF) [C148]
45	VCKYTV1EB102K	AD		C	Capacitor(25WV 1000PF) [C149]
46	VCKYTV1EB102K	AD		C	Capacitor(25WV 1000PF) [C150]
47	VCKYTV1EF103Z	AA		C	Capacitor(25WV 0.010μF) [C151]
48	QCNCW2527SC3J	AM		C	Connector(30pin) [CN1]
49	QCNCM2484SC0B	AB		C	Connector(2pin) [CN2]
50	QCNCM2584SC0B	AC		C	Connector(2pin) [CN3]
51	QCNCM2584SC1A	AG		C	Connector(11pin) [CN4]
52	QCNCM2584SC0G	AE		C	Connector(7pin) [CN5]
53	QCNCM2584SC0D	AD		C	Connector(4pin) [CN6]
54	QCNCM2484SC0H	AD		C	Connector(8pin) [CN7]
55	QCNCM2584SC0C	AC		C	Connector(3pin) [CN8]
56	QCNCM2584SC0E	AD		C	Connector(5pin) [CN9]
57	QCNCM2498SC0B	AB		C	Connector(2pin) [CN10]
58	QCNCM2584SC1C	AG		C	Connector(13pin) [CN11]
59	QCNCM2498SC0D	AD		C	Connector(4pin) [CN13]
60	QCNCM2401SC0D	AC		C	Connector(4pin) [CN14]
61	QCNCM2585SC0D	AD		C	Connector(4pin) [CN15]
62	VHD1SS226//1	AB		B	Diode(1SS226) [D100]

NO.	PARTS CODE	PRICE RANK	NEW MARK	PART RANK	DESCRIPTION
[17] Printer PWB unit					
63	VHD1SS355/-1	AB		B	Diode(1SS355) [D101]
64	VHVICPS18/-1	AE		B	Varistor [F100]
65	LPLTM3029XHZZ	AF		C	Heat sink [H1]
66	VHITEA3718SDP	BA		B	IC,MOTOR DRIVER(TEA3718SDP) [IC1]
67	VHIM38073M/-1	BK		B	IC,CPU(M38073E4FP) [IC2]
68	VHIULN2003ADR	AF		B	IC,TRANSISTOR ARRAY(ULN2003A) [IC3]
69	VHITEA3718SDP	BA		B	IC,MOTOR DRIVER(TEA3718SDP) [IC4]
70	VHI74VHC02F-1	AF		B	IC,HCMOS(74VHC02) [IC5]
71	VSDTD123YK/-1	AC		B	Transistor(DTD123YK) [Q100]
72	VSDTB114EK/-1	AD		B	Transistor(DTB114EK) [Q101]
73	VSDTC114YU/-1	AC		B	Transistor(DTC114YU) [Q102]
74	VSDTC114YU/-1	AC		B	Transistor(DTC114YU) [Q103]
75	VSDTC114YU/-1	AC		B	Transistor(DTC114YU) [Q104]
76	VRS-TS2AD472J	AA		C	Resistor(1/10W 4.7KΩ ±5%) [R1]
77	VRS-TS2AD000J	AA		C	Resistor(1/10W 0Ω ±5%) [R2]
78	VRS-TW2HF1R3J	AC		C	Resistor(1/2W 1.3Ω ±5%) [R100]
79	VRS-TW2HFR68J	AC		C	Resistor(1/2W 0.68Ω ±5%) [R101]
80	VRS-TS2AD472J	AA		C	Resistor(1/10W 4.7KΩ ±5%) [R102]
81	VRS-TS2AD563J	AA		C	Resistor(1/10W 56KΩ ±5%) [R103]
82	VRS-TS2AD472J	AA		C	Resistor(1/10W 4.7KΩ ±5%) [R104]
83	VRS-TS2AD472J	AA		C	Resistor(1/10W 4.7KΩ ±5%) [R105]
84	VRS-TS2AD103J	AA		C	Resistor(1/10W 10KΩ ±5%) [R106]
85	VRS-TS2AD472J	AA		C	Resistor(1/10W 4.7KΩ ±5%) [R107]
86	VRS-TS2AD472J	AA		C	Resistor(1/10W 4.7KΩ ±5%) [R108]
87	VRS-TW2EE221J	AB		C	Resistor(1/4W 220Ω ±5%) [R109]
88	VRS-TS2AD473J	AA		C	Resistor(1/10W 47KΩ ±5%) [R110]
89	VRS-TS2AD102J	AA		C	Resistor(1/10W 1KΩ ±5%) [R111]
90	VRS-TS2AD103J	AA		C	Resistor(1/10W 10KΩ ±5%) [R113]
91	VRS-TS2AD103J	AA		C	Resistor(1/10W 10KΩ ±5%) [R114]
92	VRS-TS2AD393J	AA		C	Resistor(1/10W 39KΩ ±5%) [R115]
93	VRS-TS2AD682J	AA		C	Resistor(1/10W 6.8KΩ ±5%) [R116]
94	VRS-TS2AD472J	AA		C	Resistor(1/10W 4.7KΩ ±5%) [R117]
95	VRS-TS2AD103J	AA		C	Resistor(1/10W 10KΩ ±5%) [R118]
96	VRS-TS2AD472J	AA		C	Resistor(1/10W 4.7KΩ ±5%) [R119]
97	VRS-TS2AD103J	AA		C	Resistor(1/10W 10KΩ ±5%) [R120]
98	VRS-TW2EE100J	AB		C	Resistor(1/4W 10Ω ±5%) [R121]
99	VRS-TS2AD103J	AA		C	Resistor(1/10W 10KΩ ±5%) [R122]
100	VRS-TS2AD103J	AA		C	Resistor(1/10W 10KΩ ±5%) [R123]
101	VRS-TS2AD302J	AA		C	Resistor(1/10W 3KΩ ±5%) [R124]
102	VRS-TS2AD000J	AA		C	Resistor(1/10W 0Ω ±5%) [R125]
103	VRS-TW2HF1R3J	AC		C	Resistor(1/2W 1.3Ω ±5%) [R126]
104	VRS-TS2AD102J	AA		C	Resistor(1/10W 1KΩ ±5%) [R127]
105	VRS-TW2HFR68J	AC		C	Resistor(1/2W 0.68Ω ±5%) [R128]
106	VRS-TS2AD563J	AA		C	Resistor(1/10W 56KΩ ±5%) [R129]
107	VRS-TS2AD103J	AA		C	Resistor(1/10W 10KΩ ±5%) [R130]
108	VRS-TS2AD222J	AA		C	Resistor(1/10W 2.2KΩ ±5%) [R131]
109	VRS-TS2AD103J	AA		C	Resistor(1/10W 10KΩ ±5%) [R134]
110	VRS-TS2AD103J	AA		C	Resistor(1/10W 10KΩ ±5%) [R135]
111	VRS-TS2AD103J	AA		C	Resistor(1/10W 10KΩ ±5%) [R136]
112	VRS-TS2AD103J	AA		C	Resistor(1/10W 10KΩ ±5%) [R137]
113	VRS-TS2AD103J	AA		C	Resistor(1/10W 10KΩ ±5%) [R138]
114	VRS-TS2AD103J	AA		C	Resistor(1/10W 10KΩ ±5%) [R139]
115	VRS-TS2AD820J	AA		C	Resistor(1/10W 82Ω ±5%) [R140]
116	VRS-TS2AD272J	AA		C	Resistor(1/10W 2.7KΩ ±5%) [R141]
117	VRS-TS2AD222F	AA		C	Resistor(1/10W 2.2KΩ ±1%) [R142]
118	VRS-TS2AD472J	AA		C	Resistor(1/10W 4.7KΩ ±5%) [R143]
119	VRS-TS2AD103J	AA		C	Resistor(1/10W 10KΩ ±5%) [R144]
120	VRS-TS2AD222J	AA		C	Resistor(1/10W 2.2KΩ ±5%) [R145]
121	VRS-TS2AD103J	AA		C	Resistor(1/10W 10KΩ ±5%) [R146]
122	VRS-TS2AD103J	AA		C	Resistor(1/10W 10KΩ ±5%) [R147]
123	VRS-TS2AD680J	AA		C	Resistor(1/10W 68Ω ±5%) [R148]
124	VRS-TS2AD103J	AA		C	Resistor(1/10W 10KΩ ±5%) [R151]
125	VRS-TS2AD103J	AA		C	Resistor(1/10W 10KΩ ±5%) [R152]
126	VRS-TS2AD103J	AA		C	Resistor(1/10W 10KΩ ±5%) [R153]
127	RR-TZ3019SCZZ	AA		C	Resistor [RA1]
128	RR-TZ3019SCZZ	AA		C	Resistor [RA2]
129	RVR-Z2004SCZZ	AD		B	Variable resistor [VR1]
130	RCRSQ5030XHZZ	AF		B	Crystal(8MHz) [X1]
	(Unit)				
901	DCEKC470BXH01	BR		E	Printer PWB unit
[18] Power supply PWB unit					
1	LANGK8132PAZZ	AC		C	Bracket
2	LANGK8223PAZZ	AE		C	SW bracket
3	LANGK8224PAZZ	AE		C	Inlet bracket
4	PRDAR0331PAZZ	AE		C	Heat sink

NO.	PARTS CODE	PRICE RANK	NEW MARK	PART RANK	DESCRIPTION
[18] Power supply PWB unit					
5	PRDAR0570PAZZ	AK		C	Heat sink
6	RCORF0071PAZZ	AB		C	Ferrite beads [BJ2]
7	RC-FZ138DPAZZ	AE		C	Capacitor(250WV 0.22μF) [C1]
8	RC-FZ137DPAZZ	AE		C	Capacitor(250WV 0.1μF) [C2]
9	RC-QZ0173PAZZ	AC		C	Capacitor(125WV 1000PF) [C3]
10	RC-QZ0173PAZZ	AC		C	Capacitor(125WV 1000PF) [C4]
11	RC-QZ0176PAZZ	AD		C	Capacitor(125WV 4700PF) [C5]
12	RC-EZ0425PAZZ	AR		C	Capacitor(200WV 470μF) [C6]
13	RC-FZ137DPAZZ	AE		C	Capacitor(250WV 0.1μF) [C7]
14	RC-KZ0074PAZZ	AB		C	Capacitor(500WV 470PF) [C8]
15	RC-QZ0226PAZZ	AB		C	Capacitor(50WV 0.01μF) [C9]
16	RC-QZ0227PAZZ	AB		C	Capacitor(50WV 3300PF) [C10]
17	RC-QZS104PARK	AC		C	Capacitor(50WV 0.1μF) [C13]
18	RC-QZS473PARK	AB		C	Capacitor(50WV 0.047μF) [C14]
19	VCEAFU1VM108M	AF		C	Capacitor(35WV 1000μF) [C15]
20	VCEAFU1HM105M	AC		C	Capacitor(50WV 1μF) [C16]
21	VCEAFU1AM228M	AF		C	Capacitor(10WV 2200μF) [C17]
22	RC-QZ0221PAZZ	AD		C	Capacitor(250WV 0.01μF) [C19]
23	VCEAFU1HM105M	AC		C	Capacitor(50WV 1μF) [C21]
24	QPLGZ0587PAZZ	AE		C	Connector(8pin) [CN1]
25	QPLGZ0526PAZZ	AD		C	Connector(3pin) [CN2]
26	QPLGJ2217YAZZ	AC		C	Connector(2pin) [CN3]
27	QPLGJ2672YAZZ	AD		C	Connector(3pin) [CN4]
28	QPLGZ0347PAZZ	AF		C	Connector(12pin) [CN5]
29	QSOCA0030PAZZ	AG		C	AC socket [CNAC]
30	VHD1SS244/-/1	AC		B	Diode(1SS244) [D1]
31	VHDFMXG12S/-1	AG		B	Diode(FMXG12S) [D2]
32	VHDFMB-24M/-1	AF		B	Diode(FMB-24M) [D3]
33	VHDERA2206/-1	AD		B	Diode(ERA22-06) [D4]
34	VHD1SS270A/-1	AA		B	Diode(1SS270A) [D5]
35	VHDD3SBA60/-1	AG		B	Diode(D3SBA60) [DB2]
36	QFS-F0046PAZZ	AD		A	Fuse(125V 4A) [FS1]
37	QFSHA0016PAZZ	AC		C	Fuse-holder [FS1]
38	QFS-F0020PAZZ	AD		A	Fuse(125V 8A) [FS2]
39	QFSHA0016PAZZ	AC		C	Fuse-holder [FS2]
40	QFS-F0046PAZZ	AD		A	Fuse(125V 4A) [FS3]
41	QFSHA0016PAZZ	AC		C	Fuse-holder [FS3]
42	QFS-F0046PAZZ	AD		A	Fuse(125V 4A) [FS4]
43	QFSHA0016PAZZ	AC		C	Fuse-holder [FS4]
44	RH-IX0783PAZZ	AD		B	IC(L5431) [IC1]
45	RH-IX1659PAZZ	AP		B	IC(PQ30RV21) [IC2]
46	RTRNZ0577PACT	AK		C	Line-Filter [L1]
47	VHVC271D10A-1	AD		B	Varistor(ENC271D-10A) [NR1]
48	VHVC271D10A-1	AD		B	Varistor(ENC271D-10A) [NR2]
49	VHVC271D10A-1	AD		B	Varistor(ENC271D-10A) [NR3]
50	QSPGH0007PAZZ	AK		C	Varistor(DSA302A) [NR4]
51	RH-PX0296PAZZ	AF		B	Photo coupler(PC817X2) [PC1]
52	VHRS21MT2/-/1	AK		B	Photo coupler(S21MT2) [PC2]
53	VS2SC1213-C1A	AC		B	Transistor(2SC1213C) [Q2]
54	VSDTC114ESA-1	AC		B	Transistor(DTC114ESA) [Q3]
55	VSDTA114ESA-1	AC		B	Transistor(DTA114ESA) [Q4]
56	VS2SK2185/-/1	AL		B	Transistor(2SK2185) [Q10]
57	VRD-ST2CD474J	AA		C	Resistor(1/6W 470KΩ ±5%) [R1]
58	VRD-ST2CD274J	AB		C	Resistor(1/6W 270KΩ ±5%) [R4]
59	VRD-ST2CD274J	AB		C	Resistor(1/6W 270KΩ ±5%) [R5]
60	VRS-FT3DD220J	AC		C	Resistor(2W 22Ω ±5%) [R6]
61	VRD-ST2HF681J	AB		C	Resistor(1/2W 680Ω ±5%) [R8]
62	RR-NZ0065PAZZ	AB		C	Resistor(1/4W 3.9KΩ) [R9]
63	VRD-ST2CD223J	AA		C	Resistor(1/6W 22KΩ ±5%) [R10]
64	VRD-ST2CD473J	AA		C	Resistor(1/6W 47KΩ ±5%) [R11]
65	RR-XZ0065PAZZ	AC		C	Fusing resistor(1/6W 2.2Ω) [R12]
66	VRD-ST2CD122J	AA		C	Resistor(1/6W 1.2KΩ ±5%) [R13]
67	VRD-ST2CD331J	AA		C	Resistor(1/6W 330Ω ±5%) [R14]
68	VRD-ST2CD473J	AA		C	Resistor(1/6W 47KΩ ±5%) [R15]
69	VRD-ST2CD222J	AA		C	Resistor(1/6W 2.2KΩ ±5%) [R16]
70	VRD-ST2CD223J	AA		C	Resistor(1/6W 22KΩ ±5%) [R18]
71	RR-SZ0074PAZZ	AB		C	Resistor(2W 1KΩ) [R19]
72	RR-SZ0074PAZZ	AB		C	Resistor(2W 1KΩ) [R20]
73	VRD-ST2HF122J	AA		C	Resistor(1/2W 1.2KΩ ±5%) [R21]
74	VRD-ST2HF101J	AA		C	Resistor(1/2W 100Ω ±5%) [R22]
75	VRD-ST2HF104J	AA		C	Resistor(1/2W 100KΩ ±5%) [R24]
76	VRD-ST2CD183J	AA		C	Resistor(1/6W 18KΩ ±5%) [R25]
77	VRD-ST2CD222J	AA		C	Resistor(1/6W 2.2KΩ ±5%) [R26]
78	VRD-ST2CD222J	AA		C	Resistor(1/6W 2.2KΩ ±5%) [R27]
79	VRD-ST2CD222J	AA		C	Resistor(1/6W 2.2KΩ ±5%) [R28]
80	VRD-ST2CD330J	AA		C	Resistor(1/6W 33Ω ±5%) [R29]
81	VRD-ST2CD330J	AA		C	Resistor(1/6W 33Ω ±5%) [R30]
82	RR-XZ0078PAZZ	AC		C	Fusing resistor(1/6W 33Ω) [R35]
83	RR-XZ0076PAZZ	AC		C	Fusing resistor(1/6W 15Ω) [R41]
84	RR-SN2322PA6F	AB		C	Resistor(1/6W 23.2KΩ) [R51]

NO.	PARTS CODE	PRICE RANK	NEW MARK	PART RANK	DESCRIPTION
[18] Power supply PWB unit					
85	RR-NZ0064PAZZ	AB		C	Resistor(1/4W 1.2K Ω) [R52]
86	VRD-ST2CD124J	AB		C	Resistor(1/6W 120K Ω \pm 5%) [R62]
87	RRLY20101PAZZ	AK		B	Relay(SDT-SS-124DM) [RL1]
88	VHSTF321S/-1	AG		B	Thyristor(TF321S) [SCR1]
89	VHS03P2M//3	AG		B	Thyristor(03P2M(L)) [SCR2]
90	QSW-C0048PAZZ	AN		C	Switch(AJ7220BK) [SW1]
91	RTRNZ0674PACD	AQ		B	Trans former [T1]
92	VHH11D8R0LA-1	AF		B	Thermistor(NTH11D8R0LA) [TH1]
93	VHSTM1241I/-1	AN		B	Thyristor(TM1241I) [TRC1]
94	RVR-M0390PAZZ	AD		C	Variable resistor [VR1]
95	VHEHVS6B2//1	AC		B	Zener diode(HZS6B2) [ZD1]
96	VHEHVS15-3/-1	AC		B	Zener diode(HZS15-3) [ZD2]
97	VHEHVS6B2//1	AC		B	Zener diode(HZS6B2) [ZD3]
98	VHEHVS27-3/-1	AC		B	Zener diode(HZS27-3) [ZD4]
99	VHEHVS36-1/-1	AC		B	Zener diode(HZS36-1) [ZD5]
100	QLUGZ0008PAZZ	AC		C	SW LUG
B1	LX-BZ0241PAZZ	AA		C	Screw(3x8)
B2	LX-BZ0254PAZZ	AB		C	Screw(3x6)
B3	LX-BZ0273PAZZ	AB		C	Screw(3x6)
B4	LX-BZ0427PAZZ	AB		C	Screw(3x14)
B5	XBSSN30P06000	AA		C	Screw(3x6)
	(Unit)				
901	RDENT2135XHZZ	BM		E	Power supply PWB unit
[19] Operation panel PWB unit					
	(Unit)				
901	DCEKP496AXH03	BC		E	Operation panel PWB unit
[20] High voltage PWB unit					
	(Unit)				
901	0KW4109620201	BR		E	High voltage PWB unit
[21] Toner empty PWB unit					
	(Unit)				
901	0KW4122010202	BD		E	Toner empty PWB unit
[22] 2nd.cassette PWB unit					
1	VCKYPA1HF223Z	AA		C	Capacitor(50WV 0.022 μ F) [C1]
2	QCNCM7014SC0B	AD		C	Connector(2pin) [CN1]
3	QCNCM2584SC1C	AG		C	Connector(13pin) [CN2]
4	QCNCM7014SC1J	AC		C	Connector(10pin) [CN3]
5	QCNCM2498SC0E	AH		C	Connector(5pin) [CN4]
6	VHD1SR139-400	AB	N	B	Diode(1SR139-400) [D1]
7	VHISN74HC157N	AE		B	IC,TTL(74HC157) [IC1]
8	VHPSG206S//1	AG		B	Photo transistor(SG206S) [PC1]
9	VRD-HT2EY153J	AA		C	Resistor(1/4W 15K Ω \pm 5%) [R1]
10	VRD-HT2EY181J	AA		C	Resistor(1/4W 180 Ω \pm 5%) [R2]
11	VRD-HT2EY472J	AA		C	Resistor(1/4W 4.7K Ω \pm 5%) [R3]
12	VRD-HT2EY472J	AA		C	Resistor(1/4W 4.7K Ω \pm 5%) [R4]
13	VRD-HT2EY472J	AA		C	Resistor(1/4W 4.7K Ω \pm 5%) [R5]
14	VRD-HT2EY472J	AA		C	Resistor(1/4W 4.7K Ω \pm 5%) [R6]
15	VRD-HT2EY472J	AA		C	Resistor(1/4W 4.7K Ω \pm 5%) [R7]
16	VRD-HT2EY472J	AA		C	Resistor(1/4W 4.7K Ω \pm 5%) [R8]
	(Unit)				
901	DCEKZ472BXH01	AT	N	E	2nd.cassette PWB unit
[23] Memory PWB unit					
1	VCEAPS226AF1C	AC		C	Capacitor(16WV 22 μ F) [C4]
2	VCEAPS226AF1C	AC		C	Capacitor(16WV 22 μ F) [C9]
3	VCEAPS226AF1C	AC		C	Capacitor(16WV 22 μ F) [C10]

NO.	PARTS CODE	PRICE RANK	NEW MARK	PART RANK	DESCRIPTION
[23] Memory PWB unit					
4	VCKYTV1EF104Z	AA		C	Capacitor(25WV 0.1μF)
5	VCKYTV1EF104Z	AA		C	Capacitor(25WV 0.1μF)
6	VCKYTV1EF104Z	AA		C	Capacitor(25WV 0.1μF)
7	VCKYTV1EF104Z	AA		C	Capacitor(25WV 0.1μF)
8	VCKYTV1EF104Z	AA		C	Capacitor(25WV 0.1μF)
9	VCKYTV1EF104Z	AA		C	Capacitor(25WV 0.1μF)
10	VCKYTV1EF104Z	AA		C	Capacitor(25WV 0.1μF)
11	VCKYTV1EF104Z	AA		C	Capacitor(25WV 0.1μF)
12	VCKYTV1EF104Z	AA		C	Capacitor(25WV 0.1μF)
13	VCKYTV1EF104Z	AA		C	Capacitor(25WV 0.1μF)
14	QCNCW2590SC5J	AM	N	C	Connector(DHB-RD50-S131N-2.9)
15	VHDHRW0502A-1	AD		B	Diode(HRW0502A)
16	VHDHRW0502A-1	AD		B	Diode(HRW0502A)
17	VHIHD74HC244F	AE	N	B	IC(HD74HC244)
18	VHIHD74HC244F	AE	N	B	IC(HD74HC244)
19	VHIHD74HC244F	AE	N	B	IC(HD74HC244)
20	VHILH28F016SU	BR		B	IC(LH28F016SUT)
21	VHIHD74HC138F	AE	N	B	IC(HD74HC138)
22	VRS-TV2AD000J	AA		C	Resistor(1/10W 0Ω ±5%)
23	VRS-TV2AD472J	AA		C	Resistor(1/10W 4.7KΩ ±5%)
24	VRS-TV2AD000J	AA		C	Resistor(1/10W 0Ω ±5%)
25	VRS-TV2AD472J	AA		C	Resistor(1/10W 4.7KΩ ±5%)
26	VRS-TS2AD910J	AA		C	Resistor(1/10W 91Ω ±5%)
27	VRS-TS2AD910J	AA		C	Resistor(1/10W 91Ω ±5%)
28	VRS-TS2AD910J	AA		C	Resistor(1/10W 91Ω ±5%)
29	VRS-TS2AD910J	AA		C	Resistor(1/10W 91Ω ±5%)
30	VRS-TS2AD910J	AA		C	Resistor(1/10W 91Ω ±5%)
31	VRS-TS2AD910J	AA		C	Resistor(1/10W 91Ω ±5%)
32	VRS-TS2AD910J	AA		C	Resistor(1/10W 91Ω ±5%)
33	VRS-TS2AD910J	AA		C	Resistor(1/10W 91Ω ±5%)
34	VRS-TS2AD910J	AA		C	Resistor(1/10W 91Ω ±5%)
35	VRS-TS2AD910J	AA		C	Resistor(1/10W 91Ω ±5%)
36	VRS-TS2AD910J	AA		C	Resistor(1/10W 91Ω ±5%)
37	VRS-TS2AD910J	AA		C	Resistor(1/10W 91Ω ±5%)
38	VRS-TS2AD910J	AA		C	Resistor(1/10W 91Ω ±5%)
39	VRS-TS2AD910J	AA		C	Resistor(1/10W 91Ω ±5%)
40	VRS-TS2AD910J	AA		C	Resistor(1/10W 91Ω ±5%)
41	VRS-TS2AD910J	AA		C	Resistor(1/10W 91Ω ±5%)
42	VRS-TS2AD910J	AA		C	Resistor(1/10W 91Ω ±5%)
43	VRS-TS2AD910J	AA		C	Resistor(1/10W 91Ω ±5%)
44	VRS-TS2AD910J	AA		C	Resistor(1/10W 91Ω ±5%)
	(Unit)				
901	DCEKM473BXH01	BR	N	E	Memory PWB unit

Index

PARTS CODE	No.	PRICE RANK	NEW MARK	PART RANK
[C]				
CBSHP2079SC02	7-1	AL		C
CCASP2107XH51	3-1	BF		E
"	4-901	BF		E
CCASP2108XH01	12-901	BE		E
CCNW-4955XH01	1-1	AG		C
CGIDM2539XH01	5-901	AY		E
CPLTP2803XHC3	14-1	AV		C
CPLTP3009XHC1	14-2	AU		C
CROLP2320XH01	2-1	AZ		C
CROLR2423XH01	13-2	AV		C
[D]				
DCEKC470BXH01	1-3	BR		E
"	17-901	BR		E
DCEKC489MXHZZ	1-2	CL	N	E
"	15-901	CL	N	E
DCEKL471BXH01	1-4	AZ		E
"	16-901	AZ		E
DCEKM473BXH01	1-49	BR		E
"	23-901	BR	N	E
DCEKP496AXH03	4-1	BC		E
"	19-901	BC		E
DCEKZ472BXH01	13-3	AT	N	E
"	22-901	AT	N	E
[G]				
GCABA2327XHSB	1-5	AP	N	D
GCABB2328XHSA	1-6	AU		D
GCABC2329XHSA	1-7	AG		D
GCABD2330XHSA	1-8	AL		D
GCABE2331XHSA	1-9	AK		C
GCABG2333XHSA	13-4	AQ		C
GCABH2334XHSA	13-5	AN		C
GCASP2107XHZZ	4-2	AM		D
GCASP2108XHSA	12-1	AT		C
GCASP2109XHSA	12-2	AM		C
GCOVA2405XHSA	2-2	AK		C
GCOVA2406XHSA	13-42	AF		C
"	14-26	AF		C
GCOVA2407XHSA	13-6	AH		C
GCOVA2408XHSA	1-10	AH		D
"	13-7	AH		C
[H]				
HPNLC2399XHSA	1-11	AH	N	C
[J]				
JBTN-2184XHZZ	4-3	AK		C
JBTN-2185XHZZ	4-4	AH		C
JBTN-2187XHZZ	4-5	AE		C
JBTN-2189XHZC	4-6	AC		C
JBTN-2253XHSA	4-7	AC		C
JBTN-2254XHSA	4-8	AC		C
JBTN-2255XHSA	2-3	AD		C
[L]				
LANGF2819XHZZ	5-1	AF		C
LANGF2825XHZZ	13-8	AF		C
LANGK8132PAZZ	18-1	AC		C
LANGK8223PAZZ	18-2	AE		C
LANGK8224PAZZ	18-3	AE		C
LBNDJ2006XHZZ	1-12	AA		C
LBSHP2109XHZZ	13-9	AF		C
LBSHP2113XHZZ	7-2	AH		C
LFRM-2201XHZZ	7-3	AL		C
LFRM-2202XHZZ	1-13	AP		C
LFRM-2203XHZZ	1-14	AQ		C
LHLDW2158SCZZ	1-15	AC		C
LHLDW2182SCZZ	1-16	AC		C
LHLDW2183SCZZ	1-17	AD		C
"	6-1	AD		C
LPINS2032XHZZ	13-10	AF		C
LPLTM3011XHZZ	5-2	AK		C
LPLTM3012XHZZ	7-4	AL		C
LPLTM3013XHZZ	6-2	AK		C
LPLTM3014XHZZ	1-18	AS		C
LPLTM3015XHZZ	1-19	AE		C
LPLTM3018XHZZ	1-20	AN		C
LPLTM3019XHZZ	2-4	AD		C
LPLTM3022XHZZ	12-3	AS		C
LPLTM3024XHZZ	13-1	AX		C
LPLTM3025XHZZ	13-12	AS		C
LPLTM3027XHZZ	13-13	AW		C
LPLTM3028XHZZ	13-14	AN		C

PARTS CODE	No.	PRICE RANK	NEW MARK	PART RANK
LPLTM3029XHZZ	17-65	AF		C
LPLTM3034XHZZ	1-21	AQ		C
LPLTM3036XHZZ	2-19	AH		C
LPLTM3037XHZZ	1-23	AD		C
LPLTP2819XHZZ	5-3	AD		C
LPLTP2821XHZZ	5-4	AD		C
LPLTP2823XHZZ	4-9	AF		C
LPLTP3016XHSA	1-24	AN		C
LPLTP3017XHSA	1-25	AH		C
LPLTP3021XHZZ	12-4	AF		C
LPLTP3023XHZZ	13-15	AF		C
LPLTP3044XHZZ	13-16	AF		C
LRALP2023XHZZ	13-17	AD		C
LRALP2024XHZZ	13-18	AD		C
LSTPP2052XHZZ	5-5	AD		C
LSTY-0057AFZZ	1-50	AC		C
LX-BZ0241PAZZ	18-B1	AA		C
LX-BZ0254PAZZ	18-B2	AB		C
LX-BZ0273PAZZ	18-B3	AB		C
LX-BZ0427PAZZ	18-B4	AB		C
LX-BZ2138XHZZ	2-B1	AB		C
LX-BZ2205XHZZ	1-B7	AC		C
"	2-B2	AC		C
"	5-B2	AC		C
"	12-B2	AC		C
LX-BZ2240XHZZ	13-B5	AB		C
LX-BZ2241XHZZ	1-B8	AC		C
[M]				
MLEVP2304XHSA	5-6	AE		C
MLEVP2305XHZZ	2-5	AD		C
MLEVP2308XHZZ	13-19	AD		C
MLEVP2309XHZZ	13-20	AE		C
MLOK-2008XHZZ	13-21	AC		C
MSPRC2843XHZZ	5-7	AC		C
MSPRC2845XHZZ	5-8	AC		C
MSPRC3090XHZZ	2-7	AH		C
MSPRC3092XHZZ	12-5	AD		C
MSPRC3095XHZZ	13-23	AD		C
MSPRC3096XHZZ	13-24	AC		C
MSPRC3097XHZZ	13-25	AD		C
MSPRC3100XHZZ	2-8	AF		C
MSPRC3107XHZA	5-10			C
MSPRC3126XHZZ	5-11	AG		C
MSPRC3138XHZZ	7-5	AE		C
MSPRC3149XHZZ	2-6	AB		C
MSPRD3086XHZZ	7-6	AH		C
MSPRD3091XHZZ	2-9	AF		C
MSPRD3093XHZZ	13-22	AG	N	C
MSPRD3125XHZZ	12-6	AD		C
MSPRP2841XHZZ	7-7	AC		C
MSPRP3055XHfJ	1-26	AD		C
MSPRP3083XHZZ	5-12	AF		C
MSPRP3087XHZZ	7-8	AF		C
MSPRP3088XHZZ	7-9	AF		C
[N]				
NBRGP2128XHZA	7-10	AE		C
NBRGP2138XHZZ	7-11	AD		C
NBRGP2141XHZZ	7-12	AH		C
NGERH2319XHZZ	7-13	AD		C
NGERH2320XHZZ	7-14	AD		C
NGERH2322XHZZ	7-15	AC		C
NGERH2462XHZZ	7-16	AC		C
NGERH2463XHZZ	7-17	AC		C
NGERH2464XHZZ	6-3	AC		C
NGERH2465XHZZ	6-4	AC		C
NGERH2466XHZZ	1-27	AE		C
"	2-10	AE		C
NGERH2469XHZZ	13-26	AC		C
NGERH2470XHZZ	13-27	AC		C
NGERH2471XHZZ	13-28	AE		C
NGERP2318XHZZ	2-11	AD		C
NROLP2332XHZZ	7-18	AD		C
NROLP2334XHZA	5-13	AC		C
"	13-29	AC		C
NROLP2420XHZZ	1-28	AM		C
NROLP2421XHZZ	2-12	AM		C
NROLR2338XHZZ	7-20	AK		C
NROLR2417XHZZ	7-19	AH		C
NROLR2418XHZZ	7-21	AL		C
NROLR2419XHZZ	7-22	AK		C

PARTS CODE	No.	PRICE RANK	NEW MARK	PART RANK
NROLR2422XHZZ	13-30	AN		C
NSFTZ2306XHZZ	5-14	AD		C
NSFTZ2307XHZZ	7-23	AK		C
NSFTZ2308XHZZ	7-24	AL		C
NSFTZ2309XHZZ	13-31	AC		C
NSFTZ2312XHZZ	13-32	AC		C
[P]				
PBRS-2047SCZZ	5-15	AG		C
PBRS-2048XHZZ	7-25	AD		C
PCAPH2032XHZZ	12-7	AC		C
"	13-11	AC		C
PCUSS2097XHZZ	4-10	AC		C
PCUSS2122XHZZ	1-29	AC		C
PCUSS2127XHZZ	2-20	AC		C
PCUSU2126XHZZ	1-35	AC		C
PGIDM2539XHZZ	5-16	AL		C
PGIDM2540XHZZ	5-17	AF		C
PGIDM2541XHSA	3-2	AK		C
PGIDM2542XHSA	1-30	AD		C
PGIDM2543XHSA	1-31	AD		C
PGIDM2544XHSA	2-13	AE		C
PGIDM2545XHSA	2-14	AC		C
PGIDM2546XHZZ	2-15	AH		C
PGIDM2547XHZZ	2-16	AK		C
PGIDM2549XHZZ	12-8	AQ		C
PGIDM2552XHZZ	13-33	AM		C
PGUMM2162XHZZ	5-18	AF		C
PLEGP2071XHZZ	1-32	AE		C
"	13-34	AE		C
PMAGE2056XHZZ	13-35	AN		C
PRDAR0331PAZZ	18-4	AE		C
PRDAR0570PAZZ	18-5	AK		C
PSEL-2017XHZZ	12-9	AE		D
PSHEZ3264XHZZ	14-29	AH	N	C
PSHEZ3410XHZZ	1-33	AB		C
PSHEZ3416XHSA	4-11	AH		C
PSHEZ3418XHZZ	5-9	AC		C
PSHEZ3419XHZZ	5-19	AB		C
PSHEZ3437XHZZ	13-36	AF		C
PSHEZ3449XHZZ	12-10	AF		D
PSHEZ3449XHZR	12-11	AF		D
PSHEZ3455XHZZ	2-17	AF		C
PSHEZ3473XHZZ	1-47	AN		C
PSHEZ3474XHZZ	1-48	AF		C
PSHEZ3477XHZZ	13-41	AB	N	C
PSHEZ3478XHZZ	13-40	AB	N	C
PSHEZ3479XHZZ	7-36	AB		C
PSPA2253XHZZ	13-43	AD	N	C
PSPO-2001XHZZ	1-34	AD		C
PSPO-2002XHZZ	12-12	AF		C
PSPO-2003XHZZ	12-13	AF		C
PSPO-2004XHZZ	12-14	AF		C
PSPO-2005XHZZ	12-15	AF		C
PSTM-2015SCZZ	7-34	AX		E
PTME-2060XHZZ	2-18	AF		C
PTME-2062XHZZ	12-16	AF		C
PTME-2063XHZZ	12-17	AF		C
PTME-2064XHZZ	12-18	AF		C
PTME-2067XHZZ	7-26	AK		C
[Q]				
QACCD7618QCZZ	14-19	AQ		C
QCNCM2401SC0B	15-191	AA		C
QCNCM2401SC0D	17-60	AC		C
QCNCM2482SC2D	15-187	AB		C
QCNCM2484SC0B	17-49	AB		C
QCNCM2484SC0H	17-54	AD		C
QCNCM2498SC0B	17-57	AB		C
QCNCM2498SC0D	17-59	AD		C
QCNCM2498SC0E	22-5	AH		C
QCNCM2499SC0J	15-184	AE		C
QCNCM2525SC3J	15-188	AH		C
QCNCM2525SC4J	15-186	AK		C
QCNCM2584SC0B	17-50	AC		C
QCNCM2584SC0C	17-55	AC		C
QCNCM2584SC0D	17-53	AD		C
QCNCM2584SC0E	17-56	AD		C
QCNCM2584SC0G	17-52	AE		C
QCNCM2584SC1A	17-51	AG		C
QCNCM2584SC1C	17-58	AG		C
"	22-3	AG		C

PARTS CODE	No.	PRICE RANK	NEW MARK	PART RANK
QCNCM2585SC0D	17-61	AD		C
QCNCM2589SC5J	15-185	AL		C
QCNCM7014SC0B	15-192	AD		C
"	22-2	AD		C
QCNCM7014SC0D	15-193	AB		C
QCNCM7014SC0H	15-190	AB		C
QCNCM7014SC1B	15-189	AD		C
QCNCM7014SC1J	15-183	AC		C
"	22-4	AC		C
QCNCW2500SC0I	16-19	AF		C
QCNCW2527SC3J	17-48	AM		C
QCNCW2590SC5J	23-14	AM	N	C
QCNW-4786XHGY	14-3	AL	N	C
QCNW-4949XHZZ	4-12	AR		C
QCNW-4950XHZZ	7-27	AF		C
QCNW-4952XHZZ	1-36	AF		C
QCNW-4953XHZZ	7-28	AK		C
QCNW-4956XHZZ	1-37	AK		C
QCNW-4957XHZZ	1-38	AL		C
QCNW-4960XHZZ	1-39	AD		C
QCNW-4962XHZZ	13-37	AF		C
QCNW-4964XHZZ	13-38	AF		C
QFS-F0020PAZZ	18-38	AD	A	
QFS-F0046PAZZ	18-36	AD	A	
"	18-40	AD	A	
"	18-42	AD	A	
QFSHA0016PAZZ	18-37	AC		C
"	18-39	AC		C
"	18-41	AC		C
"	18-43	AC		C
QJAKZ2046SCBB	16-24	AH		C
QLUGZ0008PAZZ	18-100	AC		C
QPLGJ2217YAZZ	18-26	AC		C
QPLGJ2672YAZZ	18-27	AD		C
QPLGZ0347PAZZ	18-28	AF		C
QPLGZ0526PAZZ	18-25	AD		C
QPLGZ0587PAZZ	18-24	AE		C
QSOCA0030PAZZ	18-29	AG		C
QSOCZ2066SC42	15-233	AP		C
QSPGH0007PAZZ	18-50	AK		C
QSW-C0048PAZZ	18-90	AN		C
QSW-M2255SCZZ	1-40	AF		C
QSW-M2296XHZZ	1-41	AD		C
"	7-29	AD		C
QSW-M2298XHZZ	7-30	AE		C
QSW-Z2237SCZZ	7-31	AE		B
QSW-Z2285SCZZ	1-42	AK		C
QSW-Z2286XHZZ	13-39	AH		C
QTANZ2042SCZZ	16-2	AB		C
[R]				
RC-EZ0425PAZZ	18-12	AR		C
RC-FZ137DPAZZ	18-8	AE		C
"	18-13	AE		C
RC-FZ138DPAZZ	18-7	AE		C
RC-FZ3024SCZZ	16-3	AG		C
RC-FZ3039XHZZ	17-43	AB		C
RC-KZ0074PAZZ	18-14	AB		C
RC-QZS104PARK	18-17	AC		C
RC-QZS473PARK	18-18	AB		C
RC-QZ0173PAZZ	18-9	AC		C
"	18-10	AC		C
RC-QZ0176PAZZ	18-11	AD		C
RC-QZ0221PAZZ	18-22	AD		C
RC-QZ0226PAZZ	18-15	AB		C
RC-QZ0227PAZZ	18-16	AB		C
RCORF0071PAZZ	18-6	AB		C
RCORF2124XHZZ	7-32	AE		B
RCORF2125XHZZ	3-3	AE		B
RCRSP0074AFZZ	15-575	AE		B
RCRSQ2163XHZZ	15-573	AN	N	B
RCRSQ5030XHZZ	17-130	AF		B
RCRSZ2150XHZZ	15-570	AF		B
RCRSZ2151XHZZ	15-572	AF		B
RCRSZ2152XHZZ	15-574	AF		B
RCRSZ2158XHZZ	15-571	AF		B
RDENT2135XHZZ	1-43	BM		E
"	18-901	BM		E
RH-IX0783PAZZ	18-44	AD		B
RH-IX1659PAZZ	18-45	AP		B
RH-PX0296PAZZ	18-51	AF		B

PARTS CODE	No.	PRICE RANK	NEW MARK	PART RANK
RMOTZ2146XHZZ	6-5	AW		B
RR-HZ3011SCZZ	16-35	AC		C
RR-NZ0064PAZZ	18-85	AB		C
RR-NZ0065PAZZ	18-62	AB		C
RR-SN2322PA6F	18-84	AB		C
RR-SZ0074PAZZ	18-71	AB		C
"	18-72	AB		C
RR-TZ3016SCZZ	15-564	AA		C
"	15-565	AA		C
"	15-566	AA		C
"	15-567	AA		C
RR-TZ3018SCZZ	15-568	AC		C
"	15-569	AC		C
RR-TZ3019SCZZ	17-127	AA		C
"	17-128	AA		C
RR-XZ0065PAZZ	18-65	AC		C
RR-XZ0076PAZZ	18-83	AC		C
RR-XZ0078PAZZ	18-82	AC		C
RRLYD3433XHZZ	16-18	AH		B
RRLY20101PAZZ	18-87	AK		B
RTRNZ0577PACT	18-46	AK		C
RTRNZ0674PACD	18-91	AQ		B
RTRNZ2163SCZZ	16-57	AH		B
RUNT22038SCA4	7-33	AZ		E
RVR-M0390PAZZ	18-94	AD		C
RVR-Z2004SCZZ	17-129	AD		B
[S]				
SPAKA006AXHZZ	14-20	AC		C
SPAKA130BXHZZ	14-6	AH		C
SPAKA146BXHZZ	14-23	AH		D
SPAKA166BXHZZ	14-22	AH		C
SPAKA229BXHZZ	14-24	AE		C
SPAKA230BXHZZ	14-25	AE		C
SPAKA241BXHZZ	14-21	AH		C
SPAKA301BXH01	14-4	AK	N	D
SPAKA301BXH02	14-5	AK	N	D
SPAKA416BXHZZ	14-28		N	D
SPAKA505AXHZZ	14-7	AF		D
SPAKA506AXHZZ	14-8	AP		D
SPAKC515ASCZZ	14-9	AR	N	D
SPAKC515AXHZZ	14-9	AR	N	D
SPAKP261BXHZZ	14-10	AM		D
SSAKA1430QCZZ	14-11	AB		D
SSAKA2003XHZZ	14-12	AA		D
SSAKA2342QCZZ	14-27	AA		C
[T]				
TINSE3926XHZA	14-13	AQ		D
TLABH262AXHZZ	1-44	AE		D
TLABH263AXHZZ	12-19	AE		D
TLABH4813XHSA	14-14	AE		D
TLABH4815XHSA	12-20	AE		D
TLABM2506XHZZ	14-15	AB		D
TLABM4804XHZZ	14-16	AA		D
TLABN1235CCZZ	1-45	AA		D
TLABP3078SCZZ	1-46	AA		D
TLABP3937XHZZ	14-17	AD		D
TLABS328AXHZZ	1-22	AC	N	D
TLABS373BXHZZ	13-44	AC	N	D
TLABZ3935XHZZ	14-18	AF	N	D
[U]				
UBATL2071XHZZ	15-1	AL		B
UINK-2009SC01	7-35	BA		C
[V]				
VCCCTV1HH100D	15-119	AA		C
"	15-120	AA		C
"	15-152	AA		C
VCCCTV1HH101J	15-70	AA		C
"	15-148	AA		C
"	15-176	AA		C
VCCCTV1HH120J	15-52	AA		C
"	15-80	AA		C
"	15-133	AA		C
VCCCTV1HH150J	15-41	AA		C
"	15-64	AA		C
VCCCTV1HH180J	15-33	AA		C
"	15-134	AA		C
"	17-29	AA		C
"	17-30	AA		C
VCCCTV1HH200J	15-114	AA		C
VCCCTV1HH270J	15-113	AC		C

PARTS CODE	No.	PRICE RANK	NEW MARK	PART RANK
VCCCTV1HH3R0C	15-153	AA	N	C
VCCCTV1HH300J	15-68	AA		C
"	15-75	AA		C
VCCCTV1HH470J	15-181	AA		C
"	15-182	AA		C
VCCSTV1HL102J	15-69	AA		C
VCCSTV1HL181J	15-159	AD		C
VCCSTV1HL331J	15-44	AA		C
"	15-46	AA		C
"	15-57	AA		C
"	15-127	AA		C
VCCSTV1HL471J	15-43	AC		C
"	15-45	AC		C
VCEAEA1CW336M	15-8	AB		C
"	15-9	AB		C
"	15-11	AB		C
VCEAEA1VW476M	15-10	AH		C
VCEAFU1AM228M	18-21	AF		C
VCEAFU1HM105M	18-20	AC		C
"	18-23	AC		C
VCEAFU1VM108M	18-19	AF		C
VCEAGA1CW227M	17-2	AB		C
VCEAGA1CW476M	15-3	AB		C
"	15-4	AB		C
"	15-7	AB		C
"	15-18	AB		C
VCEAGA1EW106M	15-12	AA		C
"	15-13	AA		C
"	15-14	AA		C
"	15-15	AA		C
"	15-16	AA		C
VCEAGA1EW476M	15-17	AA		C
VCEAGA1HW105M	15-6	AB		C
VCEAGA1HW107M	15-2	AA		C
"	16-16	AA		C
VCEAGA1HW225M	16-6	AA		C
VCEAGA1HW475M	15-5	AA		C
"	16-11	AA		C
"	16-12	AA		C
"	16-13	AA		C
VCEAGA1VW476M	17-1	AB		C
VCEAPS226AF1C	23-1	AC		C
"	23-2	AC		C
"	23-3	AC		C
VCKYPA1HF223Z	22-1	AA		C
VCKYPU1HB102K	16-8	AA		C
"	16-10	AA		C
VCKYPU1HB103K	16-4	AA		C
VCKYPU1HB471K	16-14	AA		C
VCKYPU1HF223Z	16-5	AA		C
"	16-17	AA		C
VCKYTV1CF105Z	15-22	AB		C
"	15-66	AB		C
"	15-67	AB		C
"	15-72	AB		C
"	15-130	AB		C
"	15-145	AB		C
"	15-166	AB		C
"	17-28	AB		C
VCKYTV1CF225Z	15-162	AD		C
"	15-180	AD		C
VCKYTV1EB102K	17-7	AD		C
"	17-24	AD		C
"	17-25	AD		C
"	17-27	AD		C
"	17-34	AD		C
"	17-35	AD		C
"	17-36	AD		C
"	17-37	AD		C
"	17-42	AD		C
"	17-45	AD		C
"	17-46	AD		C
VCKYTV1EB104K	15-102	AA		C
"	15-128	AA		C
"	15-155	AA		C
"	15-156	AA		C
"	15-157	AA		C
"	15-158	AA		C
"	15-160	AA		C
"	15-179	AA		C

PARTS CODE	No.	PRICE RANK	NEW MARK	PART RANK
VCKYTV1EB821K	17-5	AC		C
"	17-18	AC		C
"	17-32	AC		C
"	17-38	AC		C
VCKYTV1EF103Z	17-3	AA		C
"	17-4	AA		C
"	17-6	AA		C
"	17-8	AA		C
"	17-9	AA		C
"	17-10	AA		C
"	17-11	AA		C
"	17-12	AA		C
"	17-13	AA		C
"	17-14	AA		C
"	17-15	AA		C
"	17-16	AA		C
"	17-17	AA		C
"	17-19	AA		C
"	17-21	AA		C
"	17-22	AA		C
"	17-23	AA		C
"	17-26	AA		C
"	17-33	AA		C
"	17-47	AA		C
VCKYTV1EF104Z	15-19	AA		C
"	15-20	AA		C
"	15-21	AA		C
"	15-23	AA		C
"	15-25	AA		C
"	15-26	AA		C
"	15-27	AA		C
"	15-30	AA		C
"	15-31	AA		C
"	15-32	AA		C
"	15-34	AA		C
"	15-35	AA		C
"	15-36	AA		C
"	15-37	AA		C
"	15-39	AA		C
"	15-42	AA		C
"	15-47	AA		C
"	15-48	AA		C
"	15-49	AA		C
"	15-50	AA		C
"	15-51	AA		C
"	15-53	AA		C
"	15-58	AA		C
"	15-59	AA		C
"	15-61	AA		C
"	15-63	AA		C
"	15-71	AA		C
"	15-73	AA		C
"	15-74	AA		C
"	15-76	AA		C
"	15-77	AA		C
"	15-78	AA		C
"	15-81	AA		C
"	15-82	AA		C
"	15-83	AA		C
"	15-84	AA		C
"	15-86	AA		C
"	15-87	AA		C
"	15-88	AA		C
"	15-89	AA		C
"	15-93	AA		C
"	15-95	AA		C
"	15-96	AA		C
"	15-97	AA		C
"	15-98	AA		C
"	15-99	AA		C
"	15-100	AA		C
"	15-101	AA		C
"	15-104	AA		C
"	15-106	AA		C
"	15-111	AA		C
"	15-112	AA		C
"	15-115	AA		C
"	15-117	AA		C
"	15-118	AA		C
"	15-121	AA		C

PARTS CODE	No.	PRICE RANK	NEW MARK	PART RANK
VCKYTV1EF104Z	15-122	AA		C
"	15-123	AA		C
"	15-124	AA		C
"	15-125	AA		C
"	15-126	AA		C
"	15-129	AA		C
"	15-131	AA		C
"	15-132	AA		C
"	15-136	AA		C
"	15-137	AA		C
"	15-147	AA		C
"	15-154	AA		C
"	15-161	AA		C
"	15-163	AA		C
"	15-164	AA		C
"	15-165	AA		C
"	15-167	AA		C
"	15-168	AA		C
"	15-169	AA		C
"	15-171	AA		C
"	15-172	AA		C
"	15-173	AA		C
"	15-178	AA		C
"	23-4	AA		C
"	23-5	AA		C
"	23-6	AA		C
"	23-7	AA		C
"	23-8	AA		C
"	23-9	AA		C
"	23-10	AA		C
"	23-11	AA		C
"	23-12	AA		C
"	23-13	AA		C
VCKYTV1EF333Z	17-40	AB		C
VCKYTV1HB102K	15-56	AA		C
"	15-85	AA		C
"	15-146	AA		C
"	15-177	AA		C
VCKYTV1HB103K	15-92	AB		C
"	15-151	AB		C
VCKYTV1HB221K	15-175	AA		C
VCKYTV1HB222K	15-28	AA		C
"	15-29	AA		C
"	15-54	AA		C
"	15-55	AA		C
"	15-62	AA		C
"	15-65	AA		C
"	15-79	AA		C
"	15-90	AA		C
"	15-91	AA		C
"	15-94	AA		C
"	15-105	AA		C
"	15-107	AA		C
"	15-108	AA		C
"	15-109	AA		C
"	15-110	AA		C
"	15-116	AA		C
"	15-138	AA		C
"	15-139	AA		C
"	15-140	AA		C
"	15-141	AA		C
"	15-142	AA		C
"	15-143	AA		C
"	15-144	AA		C
"	15-149	AA		C
"	15-150	AA		C
VCKYTV1HB331K	15-174	AA	N	C
VCKYTV1HB472K	15-103	AA		C
VCKYTV1HF103Z	15-38	AA		C
"	15-40	AA		C
VCKYTV1HF104Z	15-24	AA		C
"	15-135	AA		C
"	15-170	AA		C
"	17-20	AA		C
"	17-31	AA		C
"	17-39	AA		C
"	17-41	AA		C
"	17-44	AA		C
VCQYNA1HM333K	16-9	AA		C
"	16-15	AA		C

PARTS CODE	No.	PRICE RANK	NEW MARK	PART RANK
VEEAGA1HW225M	16-7	AB	N	C
VHDDAP202U/-1	15-198	AB		B
VHDDA204K/-1	15-199	AC		B
"	15-211	AC		B
VHDDSS133//--1	16-20	AA		B
"	16-21	AA		B
VHDD3SBA60/-1	18-35	AG		B
VHDERA2206/-1	18-33	AD		B
VHDFMB-24M/-1	18-32	AF		B
VHDFMXG12S/-1	18-31	AG		B
VHDHRW0502A-1	15-201	AD		B
"	15-202	AD		B
"	15-203	AD		B
"	15-204	AD		B
"	15-205	AD		B
"	15-206	AD		B
"	15-207	AD		B
"	15-208	AD		B
"	15-209	AD		B
"	15-210	AD		B
"	15-212	AD		B
"	15-213	AD		B
"	15-214	AD		B
"	15-215	AD		B
"	15-216	AD		B
"	15-217	AD		B
"	15-218	AD		B
"	15-219	AD		B
"	15-220	AD		B
"	15-221	AD		B
"	15-222	AD		B
"	15-224	AD		B
"	15-225	AD		B
"	23-15	AD		B
"	23-16	AD		B
VHDSR104//--1	15-194	AF		B
"	15-195	AF		B
"	15-196	AF		B
"	15-197	AF		B
VHD0R5G4B42-1S	16-56	AF		B
VHD1SR139-400	22-6	AB	N	B
VHD1SS226//--1	17-62	AB		B
VHD1SS244//--1	18-30	AC		B
VHD1SS270A/-1	18-34	AA		B
VHD1SS355//--1	15-200	AB		B
"	15-223	AB		B
"	15-226	AB		B
"	15-227	AB		B
"	17-63	AB		B
VHEHZS15-3/-1	18-96	AC		B
VHEHZS27-3/-1	18-98	AC		B
VHEHZS36-1/-1	18-99	AC		B
VHEHZS6B2//--1	18-95	AC		B
"	18-97	AC		B
VHEHZ2C1//--1	16-61	AA		B
"	16-62	AA		B
"	16-66	AA		B
"	16-67	AA		B
VHEHZ27-1//--1	16-63	AB		B
VHEMTZJR2B-1	16-65	AC		B
VHE1ZC15//--1	16-64	AC		B
VHH11D8ROLA-1	18-92	AF		B
VHIAD8051//--1	15-270	AN		B
VHIBA10393F-1	15-241	AC		B
VHIBU4066BCF1	15-230	AD		B
VHIHCF4053M1T	15-254	AG		B
VHIHD7021606A	15-256	BE		B
VHIHD74HC04FM	15-235	AC		B
VHIHD74HC08FM	15-255	AF		B
"	15-257	AF		B
VHIHD74HC138F	23-21	AE	N	B
VHIHD74HC14FM	15-252	AF		B
"	15-260	AF		B
VHIHD74HC157F	15-238	AH		B
VHIHD74HC244F	23-17	AE	N	B
"	23-18	AE	N	B
"	23-19	AE	N	B
VHIHD74HC32FM	15-243	AC		B
VHIHD74HC74FM	15-249	AD		B
VHIHD74LS244F	15-250	AF		B

PARTS CODE	No.	PRICE RANK	NEW MARK	PART RANK
VHIHD74LS374F	15-248	AF		B
VHIHD74LV08T1	15-245	AE		B
VHIHD813201F1	15-242	BE		B
VHILB1845/-/1	15-237	AY		B
VHILC82103/-1	15-236	BA		B
VHILH28F016SU	23-20	BR		B
VHILH5116NA10	15-232	AL		B
VHILR38292/-1	15-240	AY		B
VHILZ9FJ59/-1	15-247	AX		B
VHIM38073M/-1	17-67	BK		B
VHIM65761FP-1	15-253	BD	N	B
VHINJM2113M-1	15-259	AG		B
VHINJM2902M-1	15-266	AF		B
VHINJM2904D-1	16-22	AG		B
VHINJM2904M-1	15-231	AE		B
"	15-267	AE		B
VHINJM78L05-1	15-272	AE		B
VHINJM78M12-1	15-268	AG	N	B
VHIPST596CMT1	15-263	AF		B
VHIR288F26/-1	15-264	BV	N	B
VHISM8578BV-1	15-258	AK		B
VHISN74HC157N	22-7	AE		B
VHITC7S00FU-1	15-269	AE		B
VHITC7S04FU-1	15-265	AD		B
VHITC74HCU04F	15-271	AE		B
VHITEA3718SDP	17-66	BA		B
"	17-69	BA		B
VHIULN2003ADR	17-68	AF		B
VHIW24010S7LE	15-251	AZ		B
"	15-262	AZ		B
VHI1M16E//J-6	15-239	AZ		B
"	15-246	AZ		B
VHI27160FAB0C	15-234	BQ	N	B
VHI74VHC02F-1	17-70	AF		B
VHI74VHC04F-1	15-244	AE		B
VHI74VHC393FT	15-261	AK		B
VHPPC814X//1	16-27	AE		B
VHPSG206S//1	22-8	AG		B
VHPTLP521-1BL	16-25	AE		B
VHPTLP627//1	16-26	AH		B
VHRS21MT2//1	18-52	AK		B
VHSTF321S//1	18-88	AG		B
VHSTM1241I/-1	18-93	AN		B
VHS03P2M//3	18-89	AG		B
VHVC271D10A-1	18-47	AD		B
"	18-48	AD		B
"	18-49	AD		B
VHVERZV5D471/	16-58	AC		B
"	16-59	AC		B
VHVICPS10//1	15-228	AG		B
VHVICPS18//1	15-229	AE		B
"	17-64	AE		B
VHVRA391PV6-1	16-1	AE		B
VHVTN07G101-1	16-60	AB		B
VP-1M1R0J0000	15-277	AC	N	C
VRD-HT2EY000J	15-296	AA		C
VRD-HT2EY100J	16-23	AA		C
"	16-41	AA		C
VRD-HT2EY103J	16-54	AA		C
"	16-55	AA		C
VRD-HT2EY104J	16-34	AA		C
VRD-HT2EY124J	16-38	AA		C
VRD-HT2EY153J	22-9	AA		C
VRD-HT2EY181J	22-10	AA		C
VRD-HT2EY183J	16-40	AA		C
VRD-HT2EY201J	16-45	AA		C
VRD-HT2EY223J	16-48	AA		C
"	16-49	AA		C
"	16-51	AA		C
"	16-53	AA		C
VRD-HT2EY224J	16-33	AA		C
VRD-HT2EY300J	16-44	AA		C
VRD-HT2EY303J	16-42	AA		C
VRD-HT2EY332J	16-52	AA		C
VRD-HT2EY472J	16-39	AA		C
"	22-11	AA		C
"	22-12	AA		C
"	22-13	AA		C
"	22-14	AA		C
"	22-15	AA		C

PARTS CODE	No.	PRICE RANK	NEW MARK	PART RANK
VRD-HT2EY472J	22-16	AA		C
VRD-HT2EY621J	16-46	AA		C
"	16-47	AA		C
VRD-HT2EY751J	16-50	AA		C
VRD-HT2EY910J	16-43	AA		C
VRD-HT2HY223J	16-37	AA		C
VRD-HT2HY910J	15-294	AA		C
"	15-295	AA		C
VRD-ST2CD122J	18-66	AA		C
VRD-ST2CD124J	18-86	AB		C
VRD-ST2CD183J	18-76	AA		C
VRD-ST2CD222J	18-69	AA		C
"	18-77	AA		C
"	18-78	AA		C
"	18-79	AA		C
VRD-ST2CD223J	18-63	AA		C
"	18-70	AA		C
VRD-ST2CD274J	18-58	AB		C
"	18-59	AB		C
VRD-ST2CD330J	18-80	AA		C
"	18-81	AA		C
VRD-ST2CD331J	18-67	AA		C
VRD-ST2CD473J	18-64	AA		C
"	18-68	AA		C
VRD-ST2CD474J	18-57	AA		C
VRD-ST2HF101J	18-74	AA		C
VRD-ST2HF104J	18-75	AA		C
VRD-ST2HF122J	18-73	AA		C
VRD-ST2HF681J	18-61	AB		C
VRS-FT3DD220J	18-60	AC		C
VRS-HT3AAR47J	15-292	AC		C
"	15-293	AC		C
VRS-HT3AA133J	16-36	AB		C
VRS-TP2BD000J	15-476	AA		C
VRS-TP2BD200J	15-543	AA		C
VRS-TP2BD222J	15-300	AA		C
VRS-TS2AD000J	15-60	AA		C
"	15-273	AA		C
"	15-274	AA		C
"	15-276	AA		C
"	15-278	AA		C
"	15-279	AA		C
"	15-298	AA		C
"	15-299	AA		C
"	15-301	AA		C
"	15-317	AA		C
"	15-320	AA		C
"	15-321	AA		C
"	15-322	AA		C
"	15-322	AA		C
"	15-323	AA		C
"	15-324	AA		C
"	15-326	AA		C
"	15-328	AA		C
"	15-329	AA		C
"	15-330	AA		C
"	15-352	AA		C
"	15-354	AA		C
"	15-369	AA		C
"	15-370	AA		C
"	15-371	AA		C
"	15-372	AA		C
"	15-373	AA		C
"	15-376	AA		C
"	15-378	AA		C
"	15-399	AA		C
"	15-402	AA		C
"	15-403	AA		C
"	15-404	AA		C
"	15-405	AA		C
"	15-406	AA		C
"	15-408	AA		C
"	15-410	AA		C
"	15-411	AA		C
"	15-412	AA		C
"	15-415	AA		C
"	15-416	AA		C
"	15-417	AA		C
"	15-419	AA		C
"	15-431	AA		C
"	15-432	AA		C

PARTS CODE	No.	PRICE RANK	NEW MARK	PART RANK
VRS-TS2AD000J	15-433	AA		C
"	15-435	AA		C
"	15-436	AA		C
"	15-440	AA		C
"	15-448	AA		C
"	15-450	AA		C
"	15-457	AA		C
"	15-480	AA		C
"	15-481	AA		C
"	15-488	AA		C
"	15-499	AA		C
"	15-502	AA		C
"	15-503	AA		C
"	15-505	AA		C
"	15-507	AA		C
"	15-508	AA		C
"	15-509	AA		C
"	15-539	AA		C
"	15-542	AA		C
"	15-544	AA		C
"	15-545	AA		C
"	15-562	AA		C
"	15-563	AA		C
"	17-77	AA		C
"	17-102	AA		C
VRS-TS2AD100J	15-275	AA		C
"	15-309	AA		C
"	15-310	AA		C
"	15-458	AA		C
"	15-459	AA		C
"	15-489	AA		C
"	15-510	AA		C
"	15-511	AA		C
"	15-512	AA		C
"	15-513	AA		C
"	15-514	AA		C
"	15-515	AA		C
"	15-516	AA		C
"	15-517	AA		C
"	15-518	AA		C
"	15-519	AA		C
"	15-520	AA		C
"	15-521	AA		C
"	15-522	AA		C
"	15-523	AA		C
"	15-524	AA		C
"	15-525	AA		C
"	15-526	AA		C
VRS-TS2AD101J	15-306	AA		C
"	15-307	AA		C
"	15-367	AA		C
"	15-368	AA		C
"	15-386	AA		C
"	15-426	AA		C
"	15-427	AA		C
"	15-475	AA		C
"	15-490	AA		C
"	15-527	AA		C
"	15-560	AA		C
"	15-561	AA		C
VRS-TS2AD102J	15-325	AA		C
"	15-335	AA		C
"	15-338	AA		C
"	15-342	AA		C
"	15-446	AA		C
"	15-472	AA		C
"	15-473	AA		C
"	15-479	AA		C
"	17-89	AA		C
"	17-104	AA		C
VRS-TS2AD103J	15-297	AA		C
"	15-304	AA		C
"	15-305	AA		C
"	15-311	AA		C
"	15-315	AA		C
"	15-357	AA		C
"	15-359	AA		C
"	15-361	AA		C
"	15-363	AA		C
"	15-364	AA		C

PARTS CODE	No.	PRICE RANK	NEW MARK	PART RANK
VRS-TS2AD103J	15-365	AA		C
"	15-379	AA		C
"	15-398	AA		C
"	15-407	AA		C
"	15-409	AA		C
"	15-413	AA		C
"	15-414	AA		C
"	15-420	AA		C
"	15-421	AA		C
"	15-422	AA		C
"	15-423	AA		C
"	15-437	AA		C
"	15-438	AA		C
"	15-442	AA		C
"	15-443	AA		C
"	15-447	AA		C
"	15-460	AA		C
"	15-461	AA		C
"	15-462	AA		C
"	15-464	AA		C
"	15-468	AA		C
"	15-470	AA		C
"	15-482	AA		C
"	15-483	AA		C
"	15-484	AA		C
"	15-491	AA		C
"	15-492	AA		C
"	15-493	AA		C
"	15-494	AA		C
"	15-501	AA		C
"	15-528	AA		C
"	15-529	AA		C
"	15-530	AA		C
"	15-531	AA		C
"	15-532	AA		C
"	15-546	AA		C
"	17-84	AA		C
"	17-90	AA		C
"	17-91	AA		C
"	17-95	AA		C
"	17-97	AA		C
"	17-99	AA		C
"	17-100	AA		C
"	17-107	AA		C
"	17-109	AA		C
"	17-110	AA		C
"	17-111	AA		C
"	17-112	AA		C
"	17-113	AA		C
"	17-114	AA		C
"	17-119	AA		C
"	17-121	AA		C
"	17-122	AA		C
"	17-124	AA		C
"	17-125	AA		C
"	17-126	AA		C
VRS-TS2AD104J	15-469	AA		C
VRS-TS2AD105J	15-308	AA		C
"	15-327	AA		C
"	15-391	AA		C
VRS-TS2AD113J	15-555	AA		C
VRS-TS2AD151J	15-395	AA		C
"	15-396	AA		C
"	15-397	AA		C
"	15-506	AA		C
VRS-TS2AD153J	15-552	AA		C
VRS-TS2AD154J	15-466	AA		C
VRS-TS2AD182J	15-318	AA		C
VRS-TS2AD183J	15-439	AA		C
"	15-441	AA		C
VRS-TS2AD203J	15-425	AA		C
"	15-444	AA		C
"	15-445	AA		C
VRS-TS2AD222F	17-117	AA		C
VRS-TS2AD222J	15-434	AA		C
"	17-108	AA		C
"	17-120	AA		C
VRS-TS2AD223F	15-331	AA		C
VRS-TS2AD223J	15-548	AA		C
"	15-553	AA		C

PARTS CODE	No.	PRICE RANK	NEW MARK	PART RANK
VRS-TS2AD223J	15-556	AA		C
VRS-TS2AD271J	15-302	AA		C
"	15-312	AA		C
"	15-314	AA		C
"	15-343	AA		C
"	15-344	AA		C
"	15-345	AA		C
"	15-346	AA		C
"	15-347	AA		C
"	15-348	AA		C
"	15-349	AA		C
"	15-350	AA		C
"	15-353	AA		C
"	15-355	AA		C
"	15-356	AA		C
"	15-360	AA		C
"	15-387	AA		C
"	15-393	AA		C
"	15-394	AA		C
"	15-400	AA		C
"	15-401	AA		C
"	15-495	AA		C
"	15-498	AA		C
VRS-TS2AD272J	17-116	AA		C
VRS-TS2AD273J	15-549	AA		C
"	15-554	AA		C
VRS-TS2AD302J	15-319	AA		C
"	15-351	AA		C
"	15-467	AA		C
"	17-101	AA		C
VRS-TS2AD330J	15-303	AA		C
"	15-339	AA		C
"	15-340	AA		C
"	15-382	AA		C
"	15-504	AA		C
VRS-TS2AD331J	15-381	AA		C
VRS-TS2AD332J	15-313	AA		C
"	15-341	AA		C
"	15-388	AA		C
"	15-389	AA		C
"	15-390	AA		C
"	15-551	AA		C
"	15-557	AA		C
"	15-559	AA		C
VRS-TS2AD333F	15-333	AB		C
VRS-TS2AD333J	15-474	AA		C
"	15-540	AA		C
"	15-541	AA		C
VRS-TS2AD393F	15-334	AA		C
VRS-TS2AD393J	17-92	AA		C
VRS-TS2AD471J	15-377	AA		C
"	15-471	AA		C
"	15-496	AA		C
"	15-497	AA		C
VRS-TS2AD472J	15-336	AA		C
"	15-362	AA		C
"	15-366	AA		C
"	15-374	AA		C
"	15-375	AA		C
"	15-380	AA		C
"	15-383	AA		C
"	15-384	AA		C
"	15-385	AA		C
"	15-418	AA		C
"	15-424	AA		C
"	15-428	AA		C
"	15-429	AA		C
"	15-430	AA		C
"	15-449	AA		C
"	15-451	AA		C
"	15-453	AA		C
"	15-454	AA		C
"	15-455	AA		C
"	15-456	AA		C
"	15-463	AA		C
"	15-477	AA		C
"	15-478	AA		C
"	15-485	AA		C
"	15-486	AA		C

PARTS CODE	No.	PRICE RANK	NEW MARK	PART RANK
VRS-TS2AD472J	15-487	AA		C
"	15-500	AA		C
"	17-76	AA		C
"	17-80	AA		C
"	17-82	AA		C
"	17-83	AA		C
"	17-85	AA		C
"	17-86	AA		C
"	17-94	AA		C
"	17-96	AA		C
"	17-118	AA		C
VRS-TS2AD473J	17-88	AA		C
VRS-TS2AD513J	15-550	AA		C
VRS-TS2AD561J	15-392	AA		C
"	15-452	AA		C
VRS-TS2AD562J	15-316	AA		C
"	15-358	AA		C
"	15-465	AA		C
VRS-TS2AD563F	15-332	AA		C
"	15-337	AA		C
VRS-TS2AD563J	17-81	AA		C
"	17-106	AA		C
VRS-TS2AD680J	17-123	AA		C
VRS-TS2AD682J	17-93	AA		C
VRS-TS2AD820J	17-115	AA		C
VRS-TS2AD822J	15-547	AA		C
VRS-TS2AD910J	23-26	AA		C
"	23-27	AA		C
"	23-28	AA		C
"	23-29	AA		C
"	23-30	AA		C
"	23-31	AA		C
"	23-32	AA		C
"	23-33	AA		C
"	23-34	AA		C
"	23-35	AA		C
"	23-36	AA		C
"	23-37	AA		C
"	23-38	AA		C
"	23-39	AA		C
"	23-40	AA		C
"	23-41	AA		C
"	23-42	AA		C
"	23-43	AA		C
"	23-44	AA		C
VRS-TV2AD000J	23-22	AA		C
"	23-24	AA		C
VRS-TV2AD472J	23-23	AA		C
"	23-25	AA		C
VRS-TW2EE100J	17-98	AB		C
VRS-TW2EE221J	17-87	AB		C
VRS-TW2HFR68J	17-79	AC		C
"	17-105	AC		C
VRS-TW2HF1R3J	17-78	AC		C
"	17-103	AC		C
VRSTS2AD1373F	15-538	AA		C
VRSTS2AD4422F	15-533	AA		C
"	15-534	AA		C
"	15-535	AA		C
"	15-536	AA		C
VRSTS2AD6812F	15-537	AA		C
VSDTA114EK/-1	15-287	AB		B
"	15-288	AB		B
VSDTA114ESA-1	18-55	AC		B
VSDTB114EK/-1	17-72	AD		B
VSDTC114EK/-1	15-283	AB		B
"	15-284	AB		B
"	15-285	AB		B
"	15-286	AB		B
"	15-289	AB		B
"	15-290	AB		B
"	15-291	AB		B
VSDTC114ES/-1	16-31	AB		B
"	16-32	AB		B
VSDTC114ESA-1	18-54	AC		B
VSDTC114YU/-1	17-73	AC		B
"	17-74	AC		B
"	17-75	AC		B
VSDTD123YK/-1	17-71	AC		B
VS2SA1037KR-1	15-282	AB		C

SHARP

COPYRIGHT © 1999 BY SHARP CORPORATION

ALL RIGHTS RESERVED.

No part of this publication may be reproduced, stored in a retrieval system, or transmitted in any form or by any means, electronic, mechanical, photocopying, recording, or otherwise, without prior written permission of the publisher.

SHARP CORPORATION
Communication Systems Group
Quality & Reliability Control Center
Higashihiroshima, Hiroshima 739-0192, Japan
Printed in U.S.A.

A9911-1834SS•IS•T